



## Evo Affinity 30Gp Residential Series Manual-Controlled Gas Cooktop With Standing Pilot Light For Indoor Use Only

Please note that the Affinity 30Gp is equipped with a Safety Gas Pilot Light system, which activates both the inner and outer burners when the gas control knob is set to Low, Medium, or High. The safety pilot light consists of a continuously lit small flame that generates a moderate heat on the cooking surface directly above it even when set to Off.

This appliance and its individual shutoff valve must be disconnected from the gas supply piping system during any pressure testing of system at test pressures in excess of 1/2 PSI (3.5kPa).

*Pour obtenir un manuel en français, veuillez appeler Evo America, LLC au 503-626-1802.*

*For a French Language Manual, please call Evo America, LLC at 503-626-1802.*

Tested &  
Listed By



Portland  
Oregon USA

OMNI-Test Laboratories, Inc.

Certification: ANSI Z21.1-2016/CSA 1.1-2016 OMNI Report # 0141GM008S

Part #: Residential Models: 10-0075-NG | 10-0075-LP

Doc: 10-29-2024

Copyright © 2024

Cleaning Instructions





[evoamerica.com](http://evoamerica.com)

# INSTALLATION INSTRUCTIONS

## Affinity 30Gp

**THIS MANUAL MUST BE RETAINED FOR FUTURE REFERENCE. READ, UNDERSTAND, AND FOLLOW THE INSTRUCTIONS AND WARNINGS CONTAINED IN THIS MANUAL.**

 <h2 style="margin: 0;">WARNING</h2>	 <h2 style="margin: 0;">WARNING</h2>
<p>It is the responsibility of the assembler/owner to assemble, install and maintain gas grill. Do not let children operate or play near your grill. Failure to follow these instructions could result in serious personal injury and / or property damage.</p>	<p>This symbol identifies the most important safety messaging in this manual. When you see this symbol, be alert to the possibility of serious bodily injury if the instructions are not followed. Be sure to read and carefully follow all of the messages.</p>

**WARNING**    POTENTIALLY HAZARDOUS SITUATION WHICH, IF NOT AVOIDED, COULD RESULT IN DEATH OR SERIOUS INJURY



**CAUTION**    POTENTIALLY HAZARDOUS SITUATION WHICH, IF NOT AVOIDED, MAY RESULT IN MINOR OR MODERATE INJURY.



**CAUTION**    Helpful tips and technique instructions are shown.



### Notes

**The installation of this cooking equipment must conform with local codes, or in the absence of local codes, with the National Fuel Gas Code, ANSI Z223.1/NFPA 54, or the Natural Gas and Propane Installation Code, CSA B149.1, as applicable.**

**To Installer or Person Uncrating Grill:**

Leave these instructions with purchaser.

**To Purchaser:**

Keep these instructions for future reference.

**Complete Now For Future Reference**

Model # \_\_\_\_\_ Serial # \_\_\_\_\_

Date Purchased \_\_\_\_\_ Location Purchased \_\_\_\_\_

Date Installed \_\_\_\_\_ Location Installed \_\_\_\_\_

## Warnings

### POST WARNING MESSAGES IN A PROMINENT LOCATION

**WARNING:** If the information in these instructions is not followed exactly, a fire or explosion may result causing property damage, personal injury or death.

- Do not store or use gasoline or other flammable vapors and liquids in the vicinity of this or any other appliance.
- **WHAT TO DO IF YOU SMELL GAS**
  - Do not try to light any appliance.
  - Do not touch any electrical switch.
  - Do not use any phone in your building.
  - Immediately call your gas supplier from a neighbor's phone. Follow the gas supplier's instructions.
  - If you cannot reach your gas supplier, call the fire department.
- Installation and service must be performed by a qualified installer, service agency or the gas supplier.

### **WARNING**

Improper installation, adjustment, alteration, service or maintenance can cause property damage, injury or death. Read the installation, operating and maintenance instructions thoroughly before installing or servicing this equipment.

### **WARNING**

**NEVER** use this appliance as a space heater to heat or warm the room. Doing so may result in carbon monoxide poisoning and overheating of the grill.

### **WARNING**

Grill is for indoor use only. Do not use this grill for space heating. Grill should be operated in a well-ventilated space. Never operate near flammable liquids or vapors. Do not install or use grill within 36" of combustible materials from back and sides of grill. Grill shall not be located under unprotected overhead made of combustible construction. Do not install grill below storage cabinets as storage cabinet contents may create a fire situation which is not visible behind closed cabinet doors.

### **WARNING**

Do not block or obstruct air ventilation for combustion.  
Do not attempt to light appliance during a power outage.

**READ FIRST**  
**IMPORTANT PRODUCT AND SAFETY INFORMATION**

**WARNING** INSTALLATION OF THIS UNIT MUST BE DONE BY A QUALIFIED PLUMBER. INCORRECT INSTALLATION CAN CAUSE INJURY TO PERSONNEL AND/OR DAMAGE TO EQUIPMENT. THIS UNIT MUST CONFORM WITH ALL LOCAL CODES, OR IN THE ABSENCE OF LOCAL CODES, WITH THE NATIONAL FUEL GAS CODE, ANSI Z223.1/NFPA 54, OR THE NATURAL GAS AND PROPANE INSTALLATION CODE, CSA B149.1, AS APPLICABLE INCLUDING:



1. THIS UNIT AND ITS INDIVIDUAL SHUTOFF VALVE MUST BE DISCONNECTED FROM THE GAS SUPPLY PIPING SYSTEM DURING ANY PRESSURE TESTING OF THE SYSTEM AT TEST PRESSURES IN EXCESS OF 1/2 PSI (3.45 kPa).

2. THIS UNIT MUST BE ISOLATED FROM THE GAS SUPPLY PIPING SYSTEM BY CLOSING ITS INDIVIDUAL MANUAL SHUTOFF VALVE DURING ANY PRESSURE TESTING OF THE GAS SUPPLY PIPING SYSTEM AT TEST PRESSURES EQUAL TO OR LESS THAN 1/2 PSI (3.5 kPa).

**WARNING** DO NOT DIRECTLY INSTALL THIS UNIT TO COMBUSTIBLE SURFACES, AND DO NOT USE COMBUSTIBLE MATERIALS IN THE CONSTRUCTION OF ANY COUNTER, STAND, OR OTHER DEVICE WHICH WILL COME INTO DIRECT CONTACT WITH THE BURNER CHASSIS



**WARNING** IMMEDIATELY AFTER CONNECTING GAS SUPPLY LINE AND BEFORE FIRST IGNITION, CHECK ALL GAS CONNECTIONS WITH SOAPY WATER TO TEST FOR LEAKS.



**WARNING** KEEP WATER AND ALL COOKING SPILL OVERS AWAY FROM FRONT CONTROL PANEL AND ALL OPEN SERVICE AREAS. NEVER HOSE UNIT, OR SPRAY UNIT WITH PRESSURIZED CLEANING SOLUTIONS.



**CAUTION** CAREFULLY FOLLOW ALL INSTALLATION INSTRUCTIONS AND CONSTRUCT ALL COUNTER SPACE, STANDS, OR OTHER SURFACES TO THE RECOMMENDED INSTALLATION SPECIFICATIONS AS OUTLINED IN THIS MANUAL.



**CAUTION** THIS UNIT IS HEAVY AND SHOULD BE INSTALLED BY TWO PEOPLE. USE NECESSARY BLOCKING FOR LOCATING AND INSTALLING COOK SURFACE.



**CAUTION** ALWAYS KEEP ANY AND ALL FLAMMABLE LIQUIDS AND COMBUSTIBLE MATERIALS AWAY FROM UNIT. DO NOT STORE TOWELS OR UTENSILS, OR ANY OTHER ITEMS ON UNIT'S DRIP PAN.



**CAUTION** DO NOT CLEAN THE COOK SURFACE WITH GRILL BRICKS OR CLEANING SOLUTIONS. USE ONLY GRILL SCREENS AND GRILL PADS AND FOLLOW THE PRESCRIBED METHOD OF CLEANING AS OUTLINED IN THIS MANUAL.



**NOTICE** THE SERIAL NUMBER AND MODEL INFORMATION LABEL PLATE IS LOCATED INSIDE THE RIGHT-SIDE SPILLOVER DOOR.



**NOTICE** INSTALLATION OF ANY VENT HOODS OR FIRE EXTINGUISHER SYSTEMS MUST CONFORM TO THE NATIONAL, STATE, AND LOCAL BUILDING AND ALL APPLICABLE UNIFORM CONSTRUCTION CODES.



**NOTICE** DURING THE FIRST FEW HOURS OF OPERATION IT IS NORMAL FOR OILS USED IN THE MANUFACTURING PROCESS TO BURN OFF AND GIVE AN ODOR OR SLIGHT PETROLEUM SMOKE.



### SAFETY LABEL

<b>Evo Affinity 30Gp Cooktop</b> <b>Affinity 30Gp Table de cuisson</b> FOR INDOOR USE Pour Usage Intérieur		Tested & Listed By  Omni Test Laboratories Portland Oregon	Residential Model # <input type="checkbox"/> 10-0075 Modèle résidentiel n° <input type="checkbox"/>																																																
THIS APPLIANCE EQUIPPED FOR USE ONLY WITH : CET APPAREIL EST ÉQUIPÉ UNIQUEMENT AVEC :		LP <input type="checkbox"/> NG <input type="checkbox"/> GPL GN	S/N / N° SÉRIE <input style="width: 100%; height: 20px;" type="text"/>																																																
Inlet Gas Pressure : Pression de gaz d'admission :		11" 7" 279.40mm 177.80mm	MANUFACTURE DATE DATE DU CONSTRUCTEUR <input style="width: 100%; height: 20px;" type="text"/>																																																
BTU Input Rate Max / Débit calorifique max. en BTU :		37,638 36,267																																																	
Drill Size Orifice No. / Dimensions de l'orifice n°		Outer Ring : #54 #44 Anneau extérieur : 1.39mm 2.18mm Inner Ring : #60 #55 Anneau intérieur : 1.01mm 1.32mm	Tested To / Testé pour: ANSI Z21.1-2016/CSA 1.1-2016 Household Cooking Appliance																																																
For conversion of gas type, refer to Gas Conversion Manual./ Pour la conversion du type de gaz, consultez le manuel de conversion au gaz.		<table border="1" style="width: 100%; border-collapse: collapse;"> <thead> <tr> <th colspan="4" style="text-align: center;">CLEARANCE TO COMBUSTIBLE SURFACES FROM CHASSIS</th> </tr> <tr> <th colspan="4" style="text-align: center;">DÉGAGEMENT AUX SURFACES COMBUSTIBLES DU CHÂSSIS</th> </tr> <tr> <th></th> <th></th> <th style="text-align: center;">Combustible</th> <th style="text-align: center;">Non-combustible</th> </tr> <tr> <th></th> <th></th> <th style="text-align: center;">Combustible</th> <th style="text-align: center;">Incombustible</th> </tr> </thead> <tbody> <tr> <td>Back</td> <td>retour</td> <td style="text-align: center;">* 3/8"</td> <td style="text-align: center;">9.53mm</td> </tr> <tr> <td>Sides</td> <td>côtés</td> <td style="text-align: center;">* 3/8"</td> <td style="text-align: center;">9.53mm</td> </tr> <tr> <td>Bottom</td> <td>bas</td> <td style="text-align: center;">3"</td> <td style="text-align: center;">76mm</td> </tr> <tr> <td colspan="4" style="text-align: center;">                     * 3/8" of cement board lined enclosure to chassis                      9.53mm de l'enceinte doublée de panneaux de ciment au châssis                 </td> </tr> <tr> <th colspan="4" style="text-align: center;">CLEARANCE TO COMBUSTIBLE SURFACES FROM COOKING PLATE</th> </tr> <tr> <th colspan="4" style="text-align: center;">DÉGAGEMENT AUX SURFACES COMBUSTIBLES DE LA PLAQUE DE CUISSON</th> </tr> <tr> <td>Top</td> <td>haut</td> <td style="text-align: center;">36"</td> <td style="text-align: center;">91cm</td> </tr> <tr> <td>Sides</td> <td>côtés</td> <td style="text-align: center;">12"</td> <td style="text-align: center;">30cm</td> </tr> </tbody> </table>		CLEARANCE TO COMBUSTIBLE SURFACES FROM CHASSIS				DÉGAGEMENT AUX SURFACES COMBUSTIBLES DU CHÂSSIS						Combustible	Non-combustible			Combustible	Incombustible	Back	retour	* 3/8"	9.53mm	Sides	côtés	* 3/8"	9.53mm	Bottom	bas	3"	76mm	* 3/8" of cement board lined enclosure to chassis 9.53mm de l'enceinte doublée de panneaux de ciment au châssis				CLEARANCE TO COMBUSTIBLE SURFACES FROM COOKING PLATE				DÉGAGEMENT AUX SURFACES COMBUSTIBLES DE LA PLAQUE DE CUISSON				Top	haut	36"	91cm	Sides	côtés	12"	30cm
CLEARANCE TO COMBUSTIBLE SURFACES FROM CHASSIS																																																			
DÉGAGEMENT AUX SURFACES COMBUSTIBLES DU CHÂSSIS																																																			
		Combustible	Non-combustible																																																
		Combustible	Incombustible																																																
Back	retour	* 3/8"	9.53mm																																																
Sides	côtés	* 3/8"	9.53mm																																																
Bottom	bas	3"	76mm																																																
* 3/8" of cement board lined enclosure to chassis 9.53mm de l'enceinte doublée de panneaux de ciment au châssis																																																			
CLEARANCE TO COMBUSTIBLE SURFACES FROM COOKING PLATE																																																			
DÉGAGEMENT AUX SURFACES COMBUSTIBLES DE LA PLAQUE DE CUISSON																																																			
Top	haut	36"	91cm																																																
Sides	côtés	12"	30cm																																																
Minimum 2" clearance between same units. Distance minimale de 51mm entre les unités. Minimum 3" clearance below unit venting to 22 sq/in of combustible air. Minimum 76mm de dégagement ci-dessous ventilation unité à 142 cm <sup>2</sup> dans l'air. Maximum depth of 13" or greater specified by manufacturer as tested by certification agency for any overhead cabinets. Profondeur maximale de 13 po ou plus spécifiée par le fabricant, testée par. Operating temperature > 30°F. /Temp de fonctionnement >-1°C.		If equipped for LP and stored indoors, detach tank and leave cylinder outdoors. Do not locate this outdoor cooking appliance under overhead unprotected combustible surface and keep leaves, grass, and other combustible material away from area below the appliance. Si l'appareil est équipé pour une utilisation avec du GPL, détacher le réservoir et laisser la bouteille à l'extérieur. Ne jamais placer cet appareil de cuisson pour l'extérieur sous une surface combustible en surplomb non protégée et garder les feuilles, l'herbe, et d'autres matériaux combustibles loin de la zone ci-dessous l'appareil.																																																	
Evo is protected under U.S Patents 6,189,530 and 6,488,022 and U.S. Patents Pending. Evo est protégé par des brevets É-U 6,189,530 et 6,488,022 et brevets É-U en instance.		Manufactured By Evo, Inc., 20560 SW 115th Ave. Tualatin, Oregon 97062 USA Made in USA./ Fabriqué aux É.-U.																																																	
		08/20/2020																																																	

## EVO RESIDENTIAL LIMITED WARRANTY TERMS

Evo America, LLC warrants to the original residential consumer-purchaser that the Evo grill shall be free from rust-through on all metal surfaces and shall be free from defects in materials and workmanship under normal and reasonable use from the original date of purchase. Evo promises to replace, at its determination, any product or component that is defective and covered under this warranty for as long as you, the registered original consumer-purchaser, owns the grill. This is your sole and exclusive remedy. This warranty is for the benefit of the original consumer-purchaser and is non-transferable. This warranty is subject to the limitations, exclusions and other provisions listed below.

### Limitations Involving Materials and Components:

Warranty does not apply to normal wear and tear, which are expected over the course of ownership. The materials and components listed below are covered according to the following schedule from the original date of purchase:

- **One Year** – electrical and electronic components [including, but not limited to, electronic displays, overlay and membrane switches, temperature sensors (RTD and K-Value Thermal Couple), hot surface igniters, computers, transformers, heater elements, relays, igniters, ignition controllers, wiring, switches, encoders, outlets and plugs]
- **One Year** – gas components [including, but not limited to, gas regulator, gas hoses, manifold assemblies]
- **One Year** – accessories and repair parts

**The Warranty Registration Card (or online warranty registration form available at [www.evoamerica.com](http://www.evoamerica.com)) must be completed and returned/submitted to Evo America, LLC within 30 days from the date of purchase. The original purchase invoice or payment record must be retained and produced upon request if claims are made under this warranty. To receive a replacement Warranty Registration Card, write or call the address listed at the bottom of this page. Warranties are void if the original serial numbers have been removed, altered, or cannot be readily determined.**

**THIS WARRANTY APPLIES ONLY TO PRODUCTS PURCHASED AND LOCATED WITHIN THE UNITED STATES OR CANADA.**

### WHAT IS NOT COVERED BY THIS WARRANTY

1. Conditions and damages resulting from any of the following:
  - a. Improper or inadequate installation, delivery, use, storage or maintenance
  - b. Any repair not authorized in writing by Evo America, LLC, any modifications, misapplications, or unreasonable use
  - c. Improper setting of any control
  - d. Harsh environmental conditions, including, but not limited to, continual seawater spray, high pressure water, and direct contact with corrosive chemicals and materials
  - e. Excessive or inadequate electrical, or gas supply
  - f. Accidents, natural disasters, acts of God
  - g. Conditions covered by the purchaser's insurance
  - h. Cleaning supplies and filters
2. Products purchased or utilized for commercial use without the express authorization of Evo America, LLC for such use
3. Labor not pre-authorized by Evo America, LLC, and labor not performed by an authorized Evo service agency or representative
4. Pre-authorized warranty labor performed outside of normal business hours, and at overtime and premium rates
5. The cost of service or a service call to:
  - a. Identify or correct installation errors
  - b. Transport the product or component for service to/from the manufacturer or service center
  - c. Instruct the user of the proper use of the product
6. The cost for any inconvenience, personal injury or property damage due to failure of the product, and cost of damage arising out of the transportation of the product which is covered under different terms with the carrier
7. Natural variations in color and finishes that are inherent to the material and unavoidable (and therefore not defects)

ALL IMPLIED WARRANTIES, INCLUDING THE IMPLIED WARRANTIES OF MERCHANTABILITY, SUITABILITY, QUALITY AND/OR FITNESS FOR A PARTICULAR PURPOSE, ARE LIMITED IN DURATION TO THE EXPRESS WARRANTY PERIODS SPECIFIED ABOVE FOR THE PARTS DESCRIBED THEREIN. EVO AMERICA, LLC MAKES NO OTHER WARRANTY AND WILL NOT BE LIABLE FOR ANY DIRECT OR INDIRECT, CONSEQUENTIAL OR INCIDENTAL DAMAGES. Some states do not allow limitations on how long an implied warranty lasts, so the above limitation may not apply to you. Neither Evo manufacturer representatives and dealers, nor the retail establishment selling this product has any authority to make any warranties or to promise remedies in addition to or inconsistent with those stated above. The maximum liability to Evo America, LLC in any event, shall not exceed the purchase price of the product paid by the original consumer-purchaser. Some states do not allow the exclusion or limitation of incidental or consequential damages, so the above limitations or exclusions may not apply to you. This warranty gives you specific legal rights, and you may also have other rights which vary from state to state.

---

---

**INSTALLATION CHECKLIST**

---

---

	PAGE #
<input type="checkbox"/> UNPACK COOKTOP COMPONENTS	6
<input type="checkbox"/> CLEARANCE DIMENSIONS	7
<input type="checkbox"/> COUNTER TOP INSTALLATION	8 - 11
<input type="checkbox"/> INSERT CHASSIS IN COUNTER TOP	12
<input type="checkbox"/> INSTALL DRIP PAN AND DRIP PAN GASKET	13 - 14
<input type="checkbox"/> INSTALLING COOK SURFACE	15
<input type="checkbox"/> CONNECTING INLET GAS LINE	16
<input type="checkbox"/> SAFETY GAS PILOT LIGHT FUNCTIONALITY	17
<input type="checkbox"/> BLEEDING AIR FROM THE GAS LINE	18
<input type="checkbox"/> LIGHTING STANDING PILOT BURNERS	19
<input type="checkbox"/> TEMPERATURE CONTROL	20
<input type="checkbox"/> REMOVABLE SPILLOVER TRAYS	21
<input type="checkbox"/> RECOGNIZING ABNORMAL GAS OPERATION	22
<input type="checkbox"/> AFFINITY 30Gp DIMENSIONS	23
<input type="checkbox"/> COOKING SURFACE MAINTENANCE	24

UNPACKING COOKTOP COMPONENTS



THE COOK SURFACE IS HEAVY. USE CAUTION WHEN LIFTING.

COOK SURFACE: LIFT AND SEPARATE COOK SURFACE FROM UNIT AND PLACE NEXT TO INSTALLATION AREA.

DRIP PAN:  
UNLATCH PAN FROM CIRCULAR SKIRT, THEN CAREFULLY LIFT AND SEPARATE DRIP PAN FROM UNIT AND PLACE NEXT TO INSTALLATION AREA. TAKE CARE NOT TO SCRATCH DRIP PAN DURING INSTALLATION.

DRIP PAN GASKET:  
GASKET INSTALLED TO TOP OF DRIP TRAY. REMOVE GASKET FROM DRIP TRAY AND SET ASIDE FOR FINAL INSTALLATION.

REMOVE TIE DOWN BOLTS AND TABS HOLDING CHASSIS TO PACKING CRATE BASE USING 7/16" WRENCH.

METAL RIGHT ANGLE BRACKETS:  
UNSCREW FROM UNIT AND KEEP SCREWS AND BRACKETS HANDY FOR FIRST INSTALLATION STEP.

CHASSIS:  
LIFT CHASSIS FROM CRATING BOX AND PLACE ON ITS SIDE NEXT TO INSTALLATION AREA.

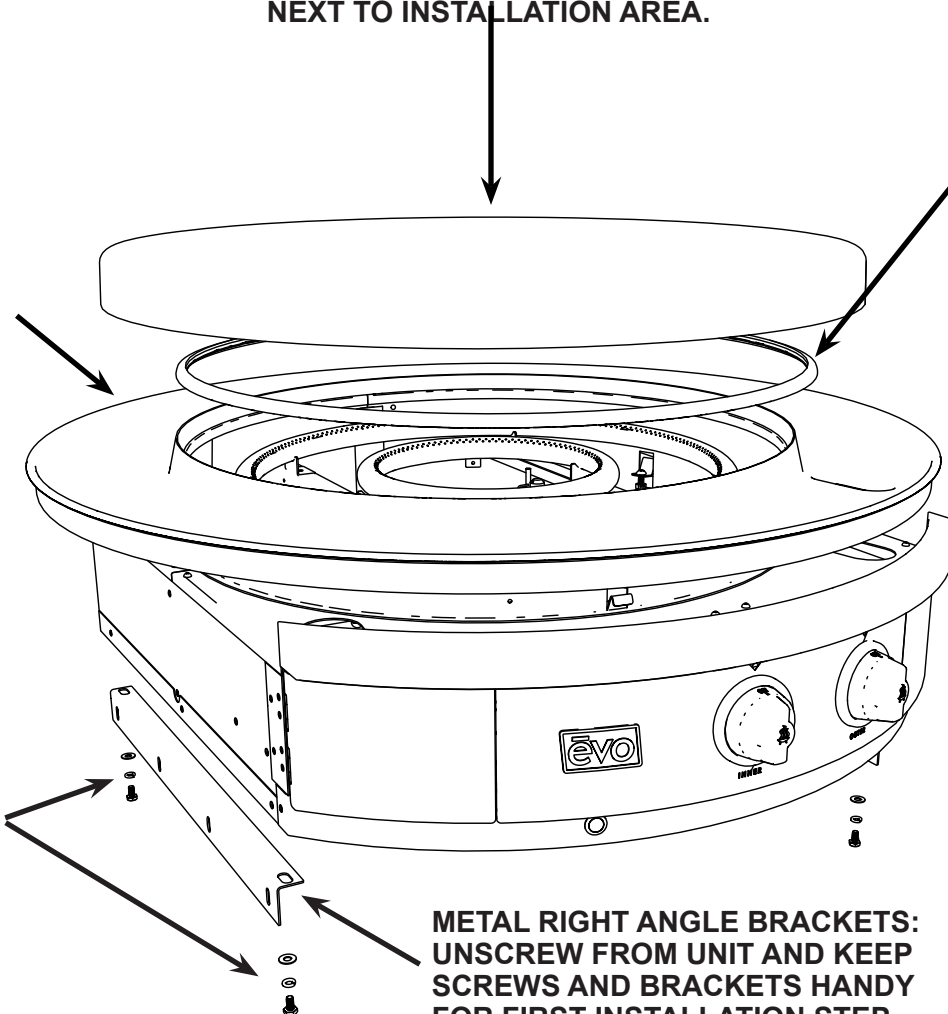

As you are unpacking the crate, make sure you locate all components before installation.



Pilot light and ignition parts are exposed during uncrating and installation. Use caution and do not alter factory set positions.

**CLEARANCE DIMENSIONS**

**36" CLEARANCE FROM COOKING SURFACE TO COMBUSTIBLE CEILING MATERIALS.  
MAXIMUM DEPTH OF CABINETS INSTALLED ABOVE TOP OF COOKING SURFACE MUST BE 13"**

**12" CLEARANCE FROM COOKING SURFACE TO COMBUSTIBLE BACK WALL MATERIALS.**

**12" CLEARANCE FROM COOKING SURFACE TO COMBUSTIBLE SIDEWALL MATERIALS.**

**IF INSTALLING ALONGSIDE ANOTHER 30Gp UNIT, PROVIDE 2" MINIMUM CLEARANCE FROM EDGE OF DRIP PANS.**

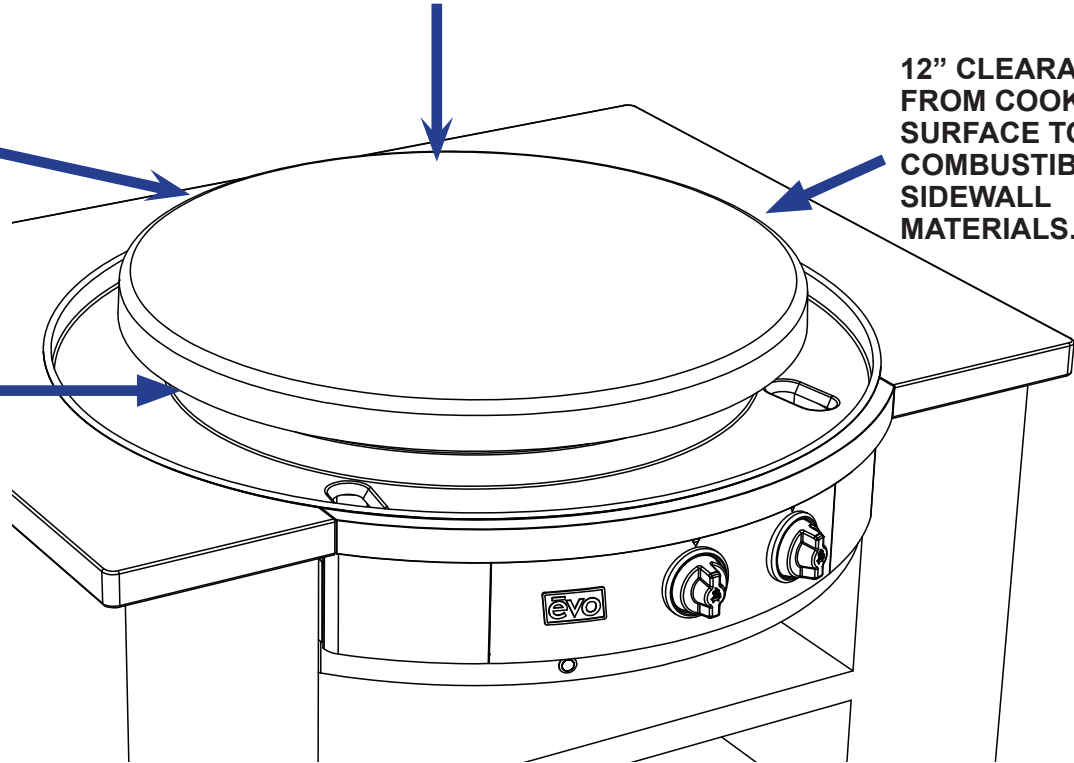

Minimum 3" clearance required under unit venting to 22 sq./in of combustible air.  
The minimum environmental temperature for safe use of the Evo Affinity 30Gp should not be below 32°F ( 0° C).

<b>CLEARANCE TO COMBUSTIBLE CONSTRUCTION FROM CHASSIS</b>		
	<b>Combustibles</b>	<b>Non-combustibles</b>
Back	* 3/8"	0"
Sides	* 3/8"	0"
Bottom	3"	3"

<b>CLEARANCE TO COMBUSTIBLE CONSTRUCTION FROM COOKING SURFACE</b>	
Top	36"
Sides	12"
Back	12"

\* 3/8" of cement board lined enclosure to chassis.

**Read the instructions carefully in this booklet to install the Evo Affinity 30Gp Cooktop to a metal, stone or wood counter top surface. Cabinet layout and construction may vary.**

COUNTER TOP INSTALLATION (1 of 4)

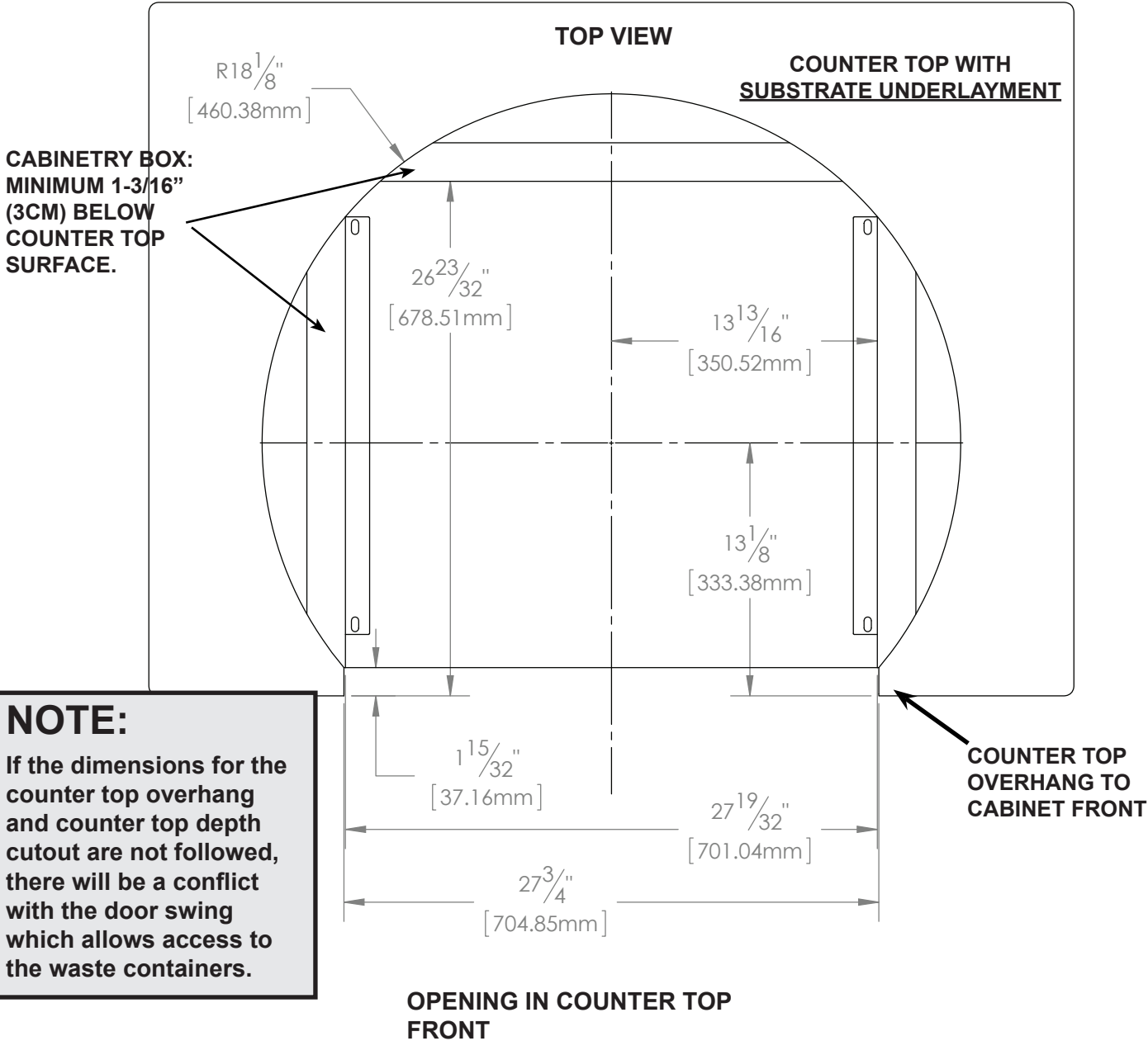

Mark the finished position of the Evo Affinity 30Gp drip pan on the counter top using the dimensions shown. The circular dimension of 36.25" is the diameter of the drip pan to the outside flange material thickness (located to the inside of the half-rolled bead edge). The drip pan cutout must be made precisely to these dimensions (or at a maximum +1/16") so the half-rolled bead on the drip pan edge overhangs the cutout dimension by 0.25".

(See following page for more detail)

COUNTER TOP INSTALLATION (2 of 4)

EXAMPLE: TILED COUNTER TOP WITH SUBSTRATE. FINISHED COUNTER TOP THICKNESS SHOULD BE 1-3/16" (3CM).

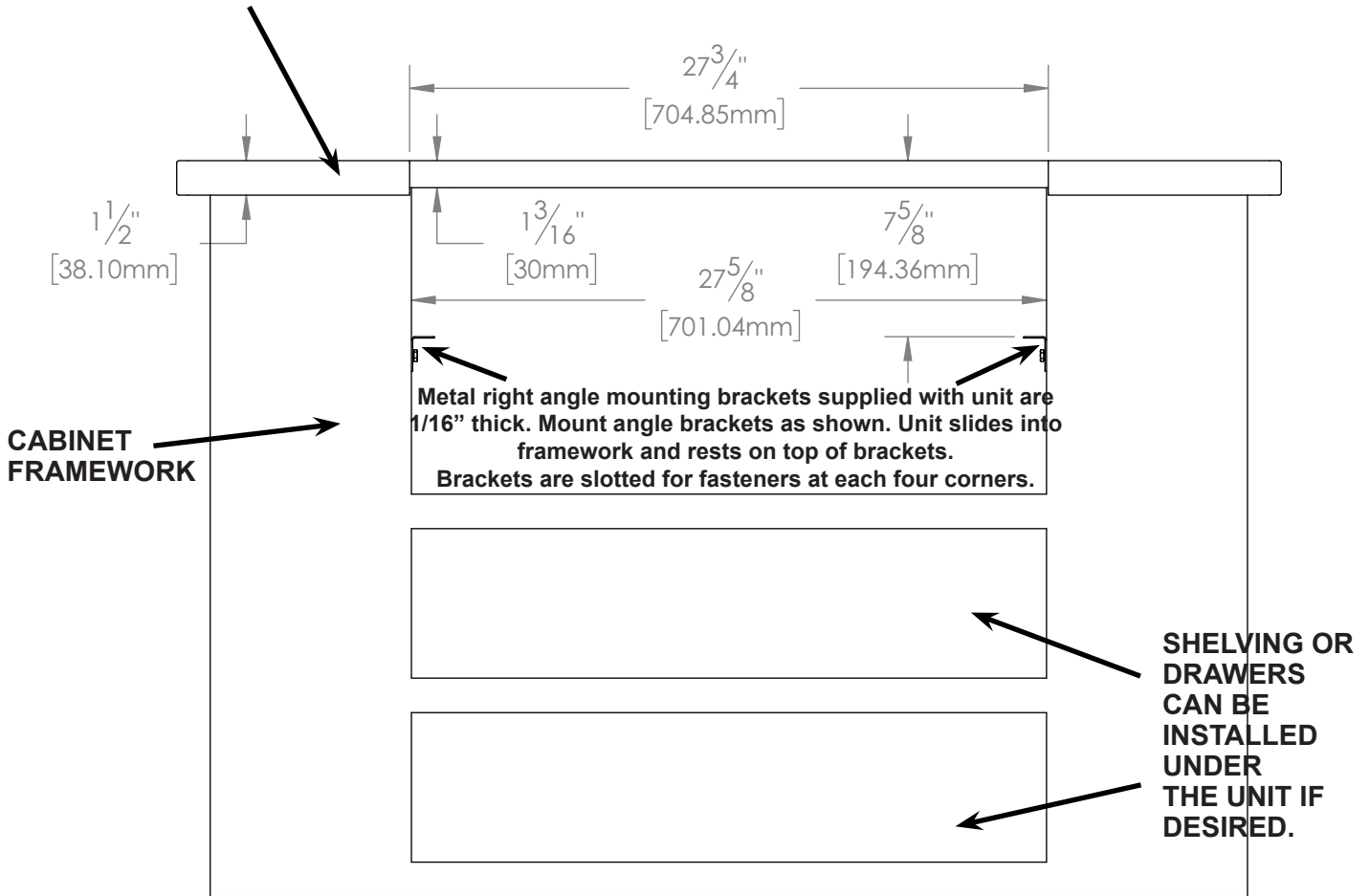

FRONT VIEW

Construct a bay for the Evo unit with your chosen cabinet system. Position and fasten the supplied mounting brackets 7-21/32" below the finished counter top surface.

COUNTER TOP INSTALLATION (3 of 4)

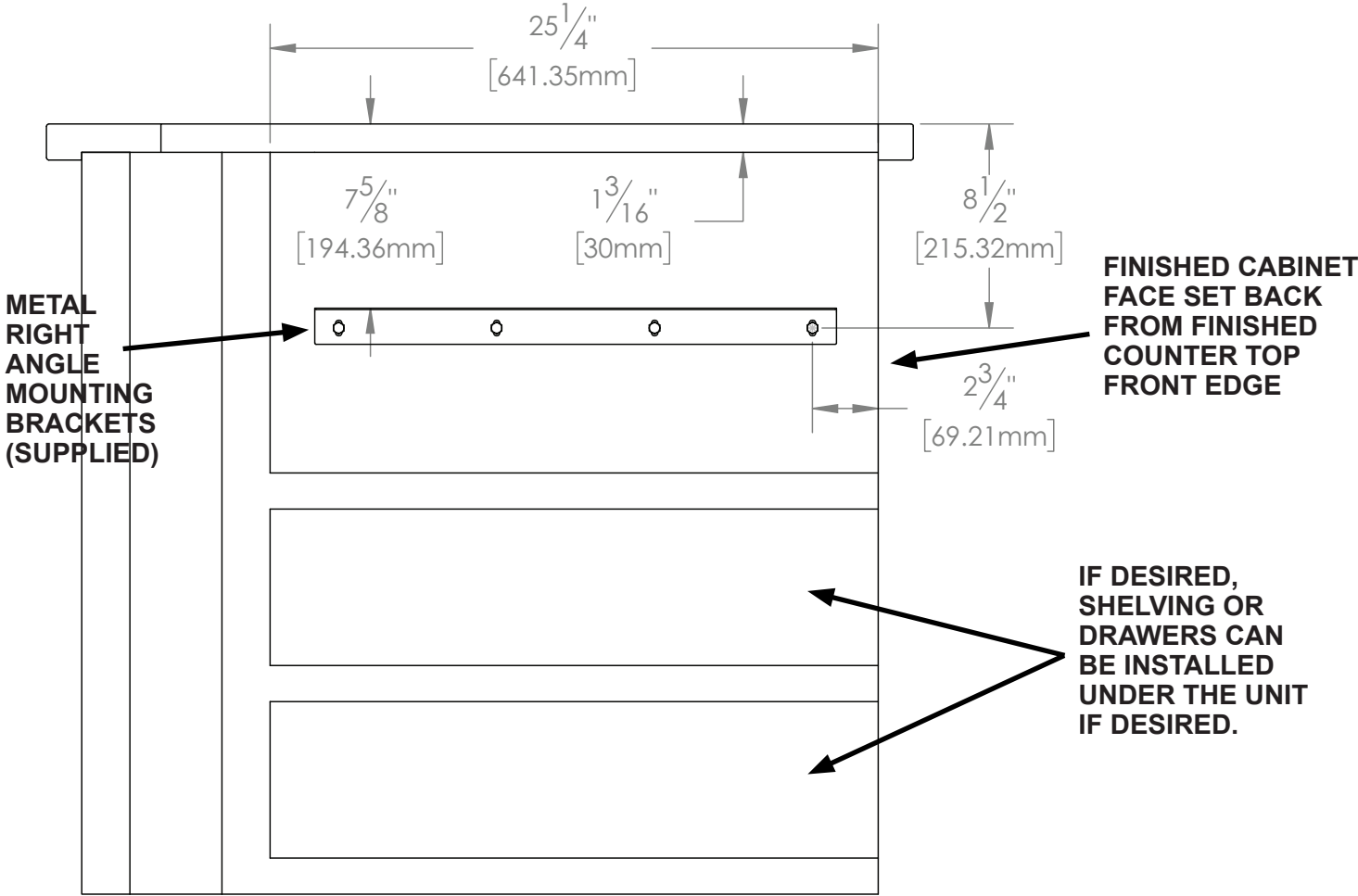

SIDE VIEW

Example of 3/8" tile with substrate for a minimum 1-3/16" (3cm) overall.  
Make sure you allow for the counter top overhang as shown.

COUNTER TOP INSTALLATION (4 of 4)

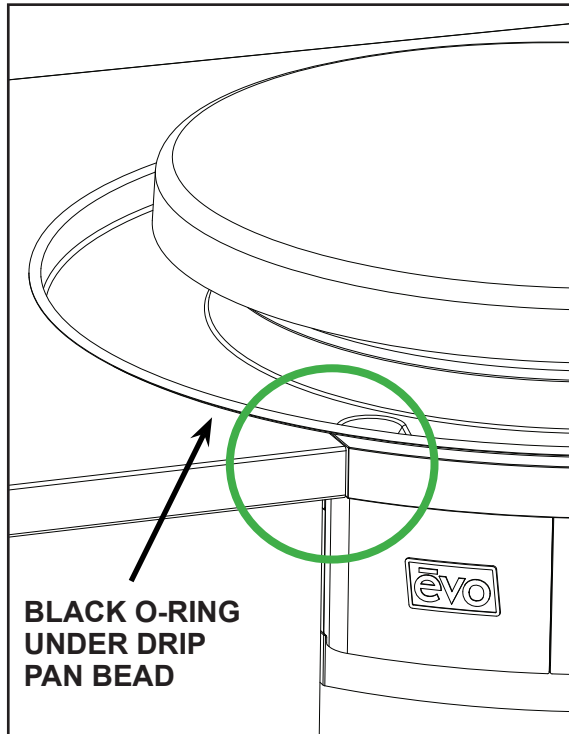

**CORRECT ALIGNMENT OF DRIP PAN  
AND CHASSIS TO COUNTER TOP**

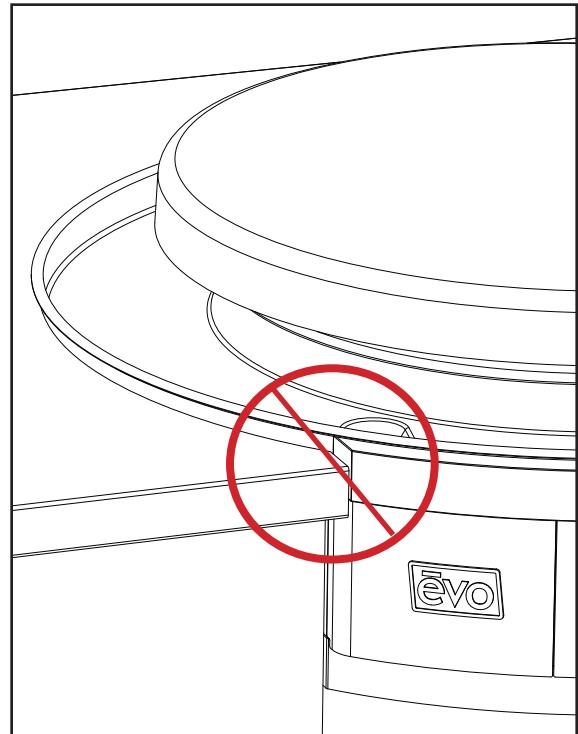

**INCORRECT ALIGNMENT OF DRIP PAN  
AND CHASSIS TO COUNTER TOP**

**POSSIBLE REASONS FOR INCORRECT ALIGNMENT:**

- 1. TOP OF CABINETRY BOX IS LESS THAN 1-3/16" (3CM) FROM COUNTER TOP.**
- 2. CHASSIS MOUNTING BRACKETS ARE TOO HIGH.**

Make sure cabinetry box is 1-1/2" below counter top surface and mounting brackets are positioned correctly so drip pan and chassis are aligned to counter top. (see diagrams above). A black o-ring is recessed in the top bead and designed to create a seal against the counter top.

INSERT CHASSIS IN COUNTER TOP

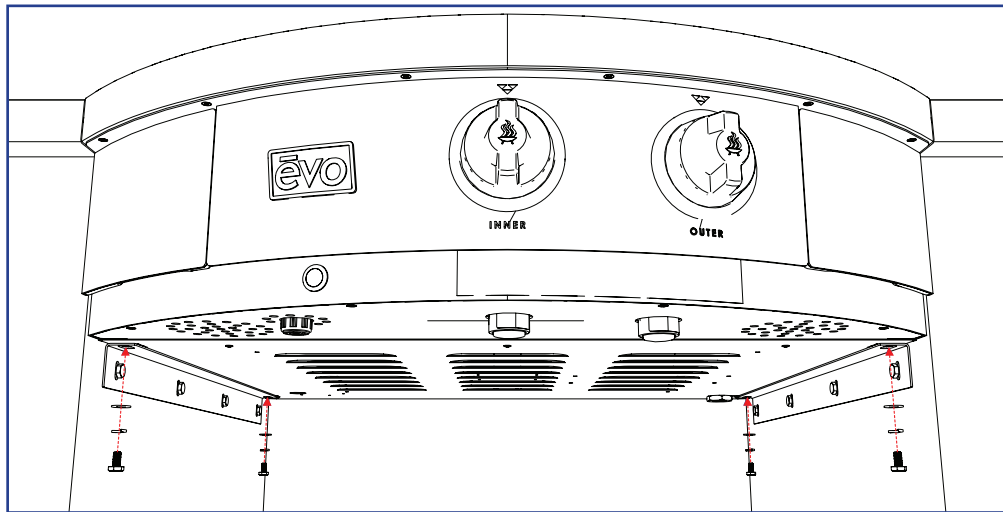
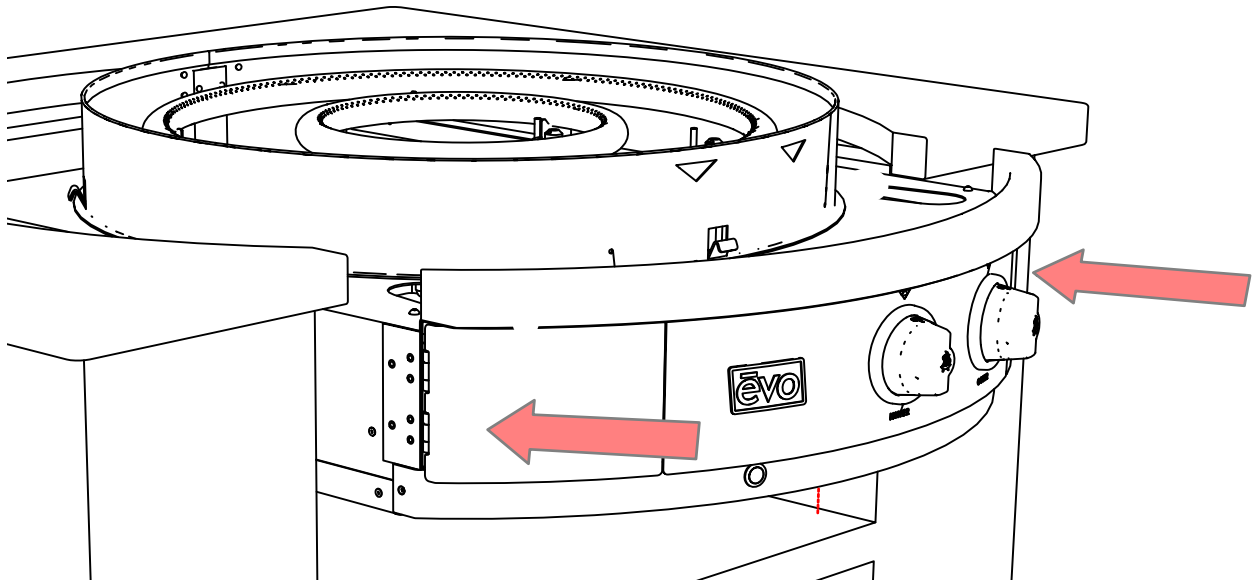

USE SUPPLIED 1/4" FASTENERS  
TO BOLT CHASSIS TO ANGLE  
BRACKETS.

Slide the Affinity 30Gp chassis into the counter top mounting enclosure so it rests on top of the installed brackets. Bolt unit to angle brackets using supplied 1/4" x 20 fasteners.



**Gas Installation must be done by a licensed plumber in accordance with local guidelines once unit has been completely installed. Refer to pages 17-18 and 21 for further instructions.**

POSITIONING DRIP PAN

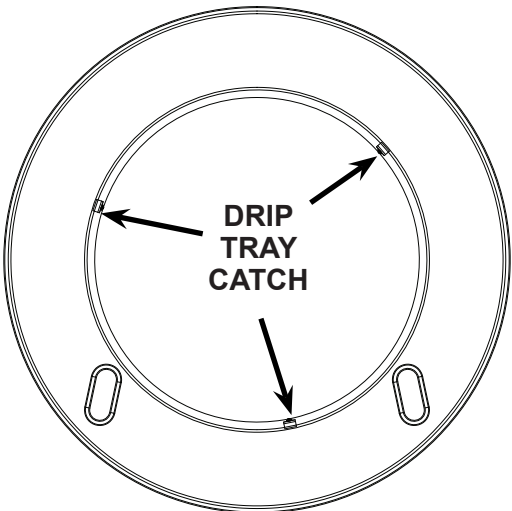
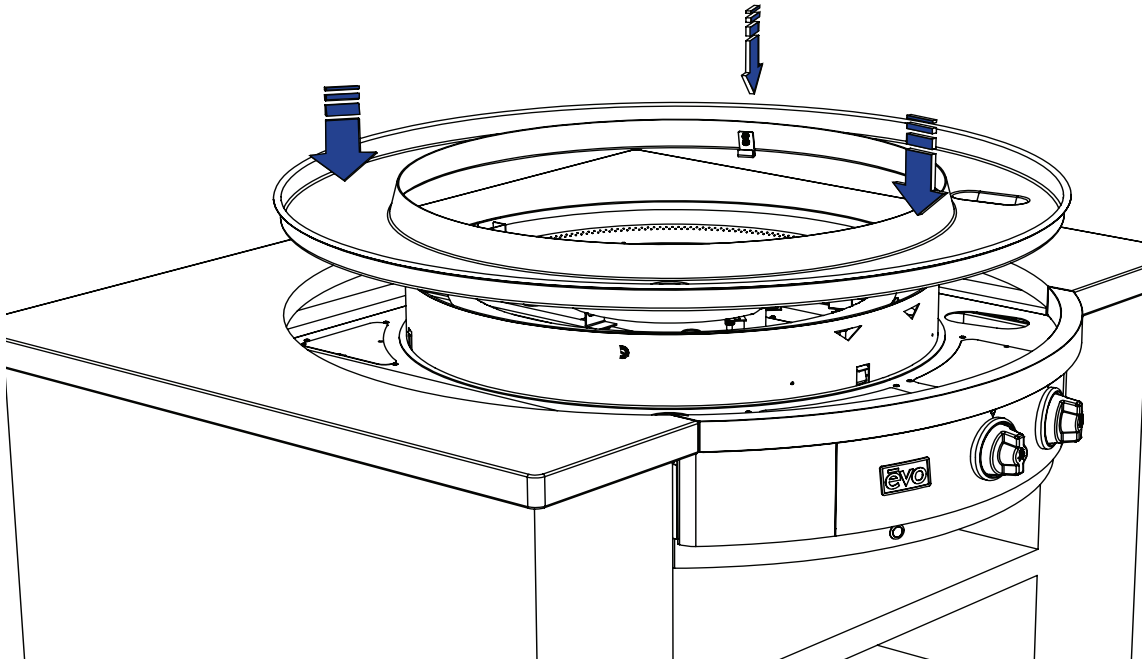

Slide drip tray over chassis circular skirt positioning spillover slots to the corresponding slots of the top chassis deck. Notice the drip pan catches showing through the inside cutout locations of the circular chassis skirt. From the inside of the skirt, use each of the three latches to pull the drip pan down into the counter.

SECURING DRIP PAN AND GASKET

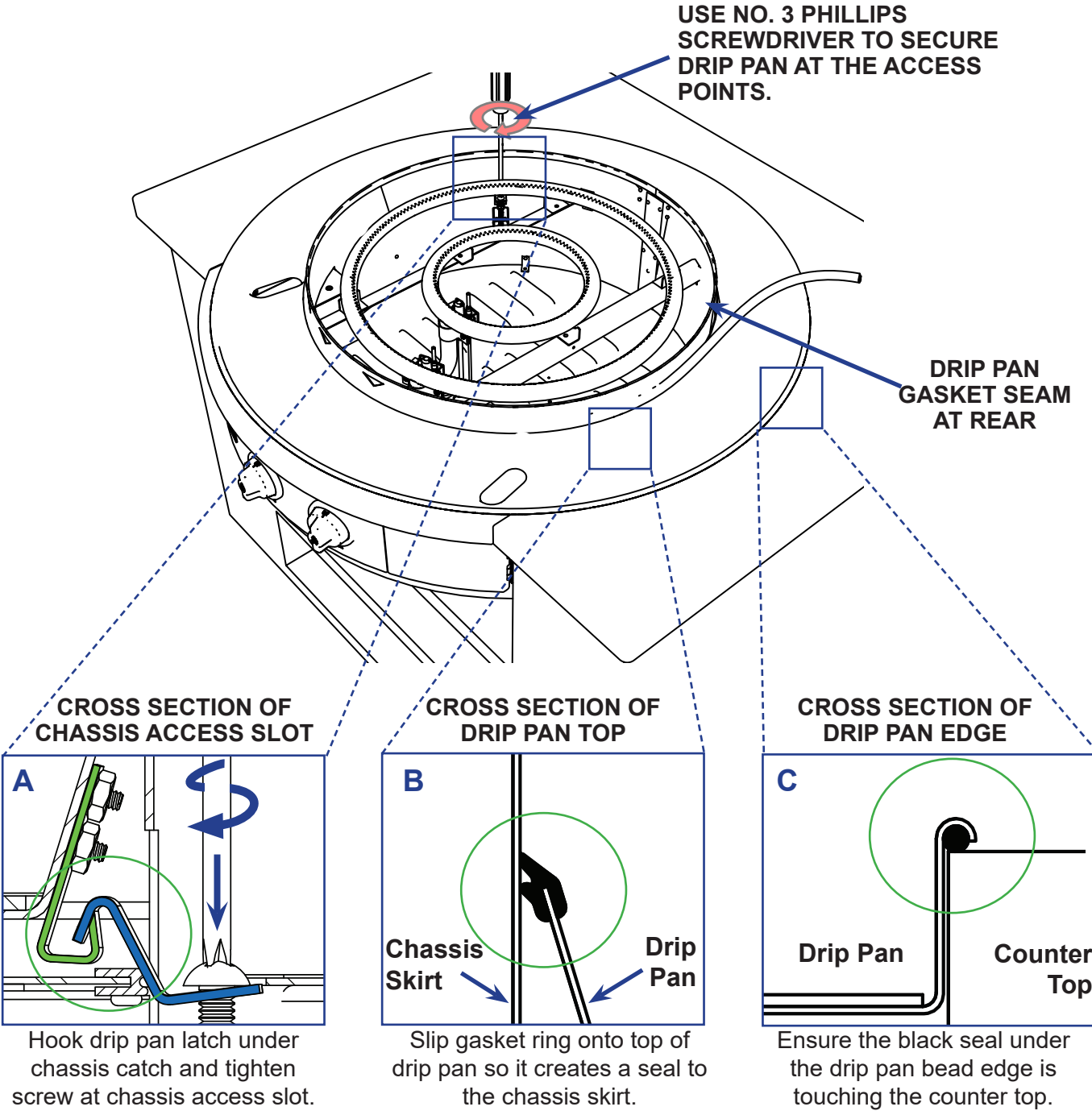

Secure drip pan to chassis using access slot (A). Rewrap drip pan gasket around top of drip tray and secure (B). Ensure seal under drip pan edge is touching counter top (C).

INSTALLING COOK SURFACE

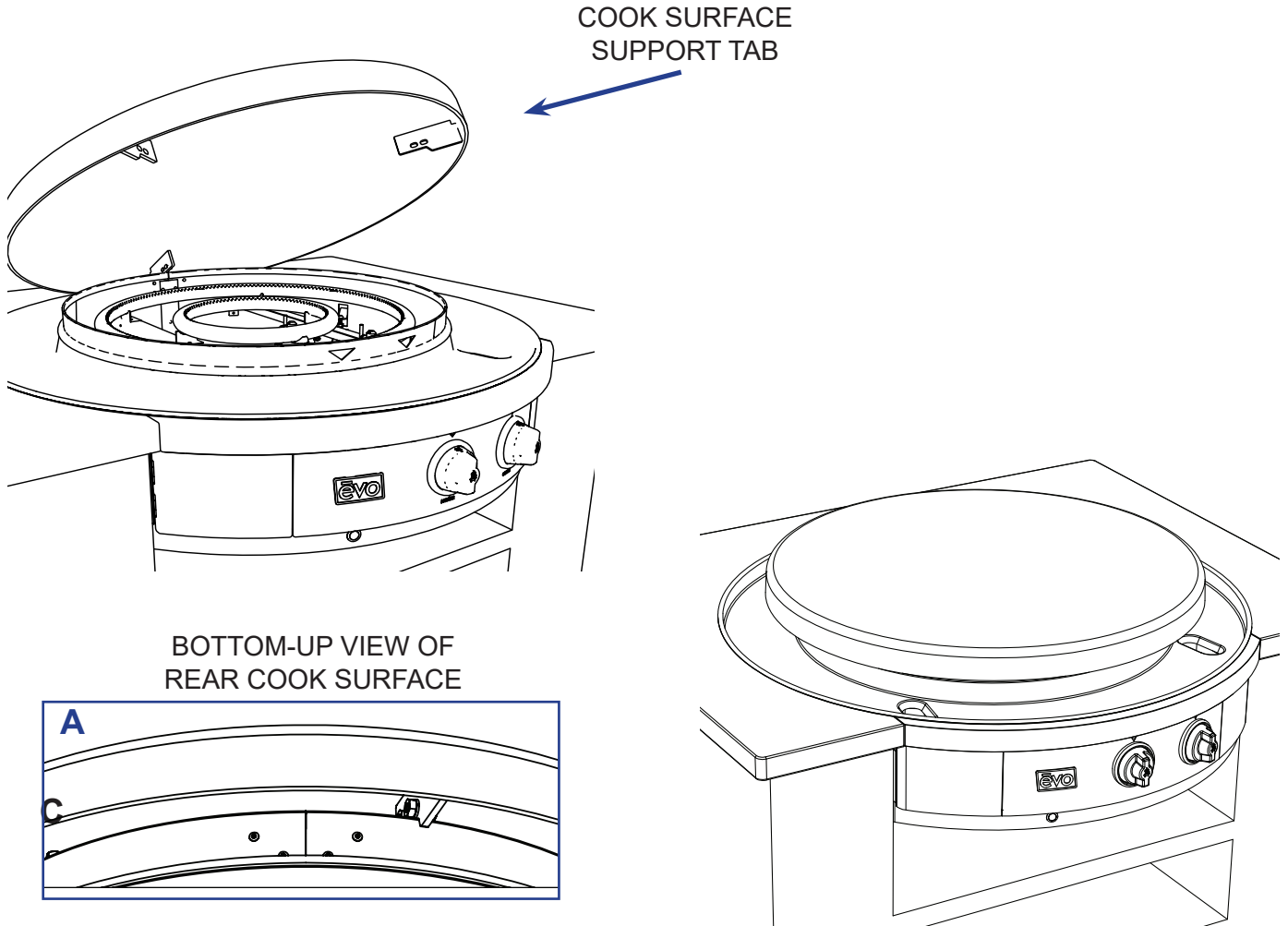

Place cook surface over circular skirt with the three support tabs (located under cook surface) resting on the chassis skirt top. Position one of the tabs of the cook surface to the right of the rear seam (rear view) of the chassis skirt (**A**). Tabs must be positioned to outside of burner skirt to allow cooking surface to be centered.

## CONNECTING INLET GAS LINE



FOR YOUR PROTECTION, A QUALIFIED PLUMBER MUST INSTALL THIS COOKTOP. THIS PERSON MUST BE FAMILIAR WITH GAS INSTALLATIONS AND ALL LOCAL CODES. PROPER CONNECTIONS ARE ESSENTIAL FOR SAFE AND EFFICIENT OPERATION.



GAS PRESSURES MUST BE CONFIGURED FOR THE TYPE OF GAS USED EITHER NATURAL GAS OF LP PROPANE GAS.



ONCE THE CHASSIS IS INSTALLED AND BEFORE CONNECTING TO AN INLET GAS SUPPLY, IT'S RECOMMENDED TO BLEED THE INPUT GAS LINE OF AIR TO REDUCE THE TIME TO ENGAGE THE GAS PILOT LIGHT BURNERS.

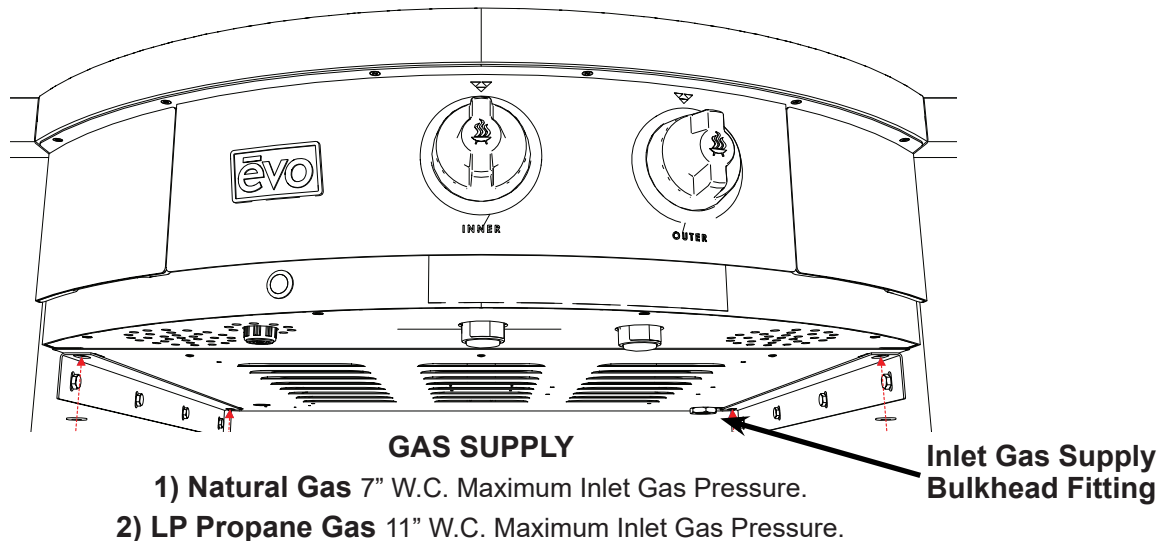

### NATURAL GAS CONNECTION:

Connect gas using 7" W.C (max) gas service.

### LP PROPANE GAS CONNECTION:

Connect gas using 11" Water Column (Fixed) gas service.

### SHUT OFF VALVE FOR GAS CONNECTION:

A manual gas shut off valve must be installed in an accessible location in the gas line external to the appliance for the purpose of turning on or shutting off gas to the appliance.

## SAFETY GAS PILOT LIGHT FUNCTIONALITY



ONCE THE CHASSIS IS INSTALLED AND BEFORE CONNECTING TO AN INLET GAS SUPPLY, IT'S RECOMMENDED TO BLEED THE INPUT GAS LINE OF AIR TO REDUCE THE TIME TO ENGAGE THE SAFETY GAS PILOT LIGHT BURNERS.

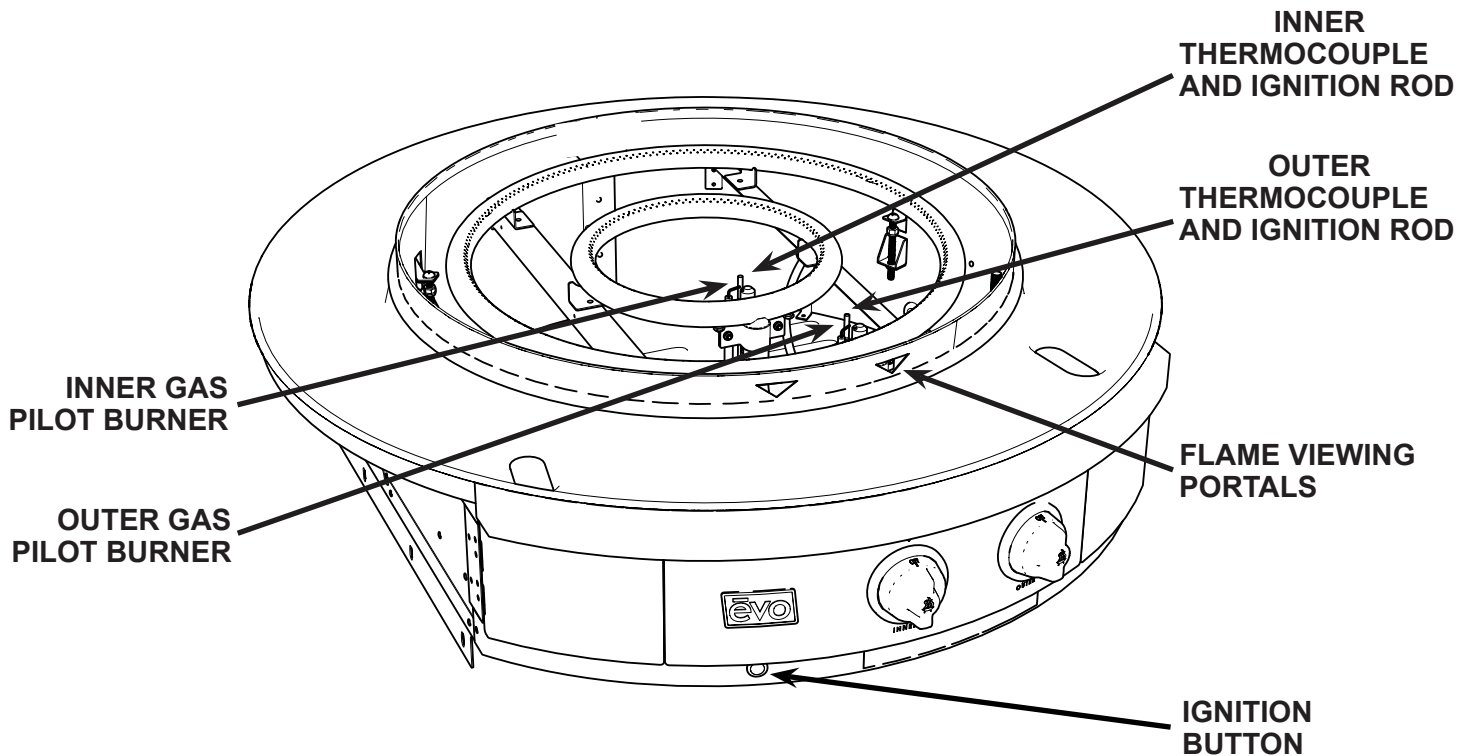

### SAFETY GAS PILOT LIGHT FUNCTION:

The Affinity 30Gp is equipped with two independently controlled circular gas burners, two Safety Gas Pilot Light valves, and a dual piezo spark ignition system. The gas pilots for both the inner and outer burners consist of a pre-configured pilot burner orifice/jet specifically for either Natural Gas or LP Propane Gas operation.

The purpose of the Safety Pilot Valve is to ensure no gas flows to the main burner manifold unless the gas pilot's are burning. When a pilot light is burning, it heats a Thermocouple probe which opens the safety valve and allows gas to flow. This "safety" feature controls situations where a gas knob is turned on and no flame is present, thereby eliminating unburned gas into an occupied space.

It is recommended the gas pilot light burners be shut off each night to minimize gas usage.

## BLEEDING AIR FROM GAS LINE



IT IS IMPORTANT TO BLEED OUT THE GAS LINE, OR 'PURGE', TO ENSURE ALL AIR POCKETS ARE REMOVED. IF YOU DO NOT BLEED YOUR GAS LINE AND THERE ARE AIR POCKETS IN THE LINE YOUR APPLIANCE MAY NOT START



IT IS EXTREMELY IMPORTANT TO ENSURE THE GAS BLEED SCREW IS COMPLETELY CLOSED TO PREVENT GAS FROM LEAKING FROM THE GAS BLEED PORT OR POTENTIALLY HAZARDOUS SITUATION WHICH, IF NOT AVOIDED, COULD RESULT IN DEATH OR SERIOUS INJURY

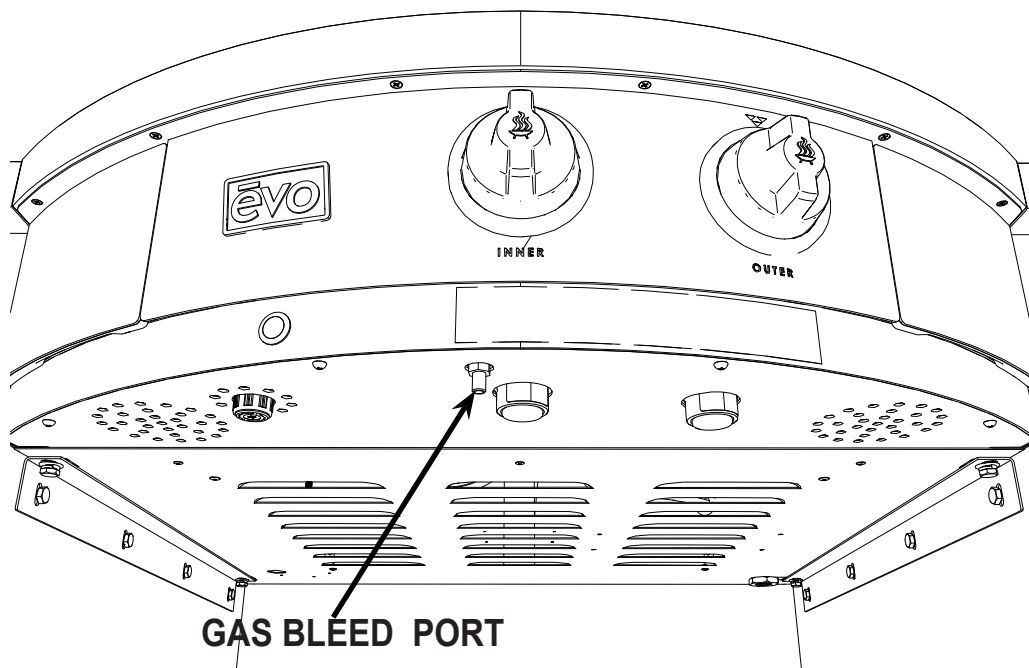

### How To Bleed The Gas Line:

**Step 1:** Turn on gas at the gas inlet valve (external to the evo appliance and supplied by others).

**Step 2:** Locate the gas bleed port, and using a small flat-blade screwdriver, open the gas bleed screw until all the air is purged from the gas line and until there is a faint smell of gas and then immediately close the bleed screw.

**Step 3:** It is extremely important to ensure the gas bleed screw is completely closed to prevent gas from leaking from the gas bleed port.

## LIGHTING STANDING PILOT BURNERS

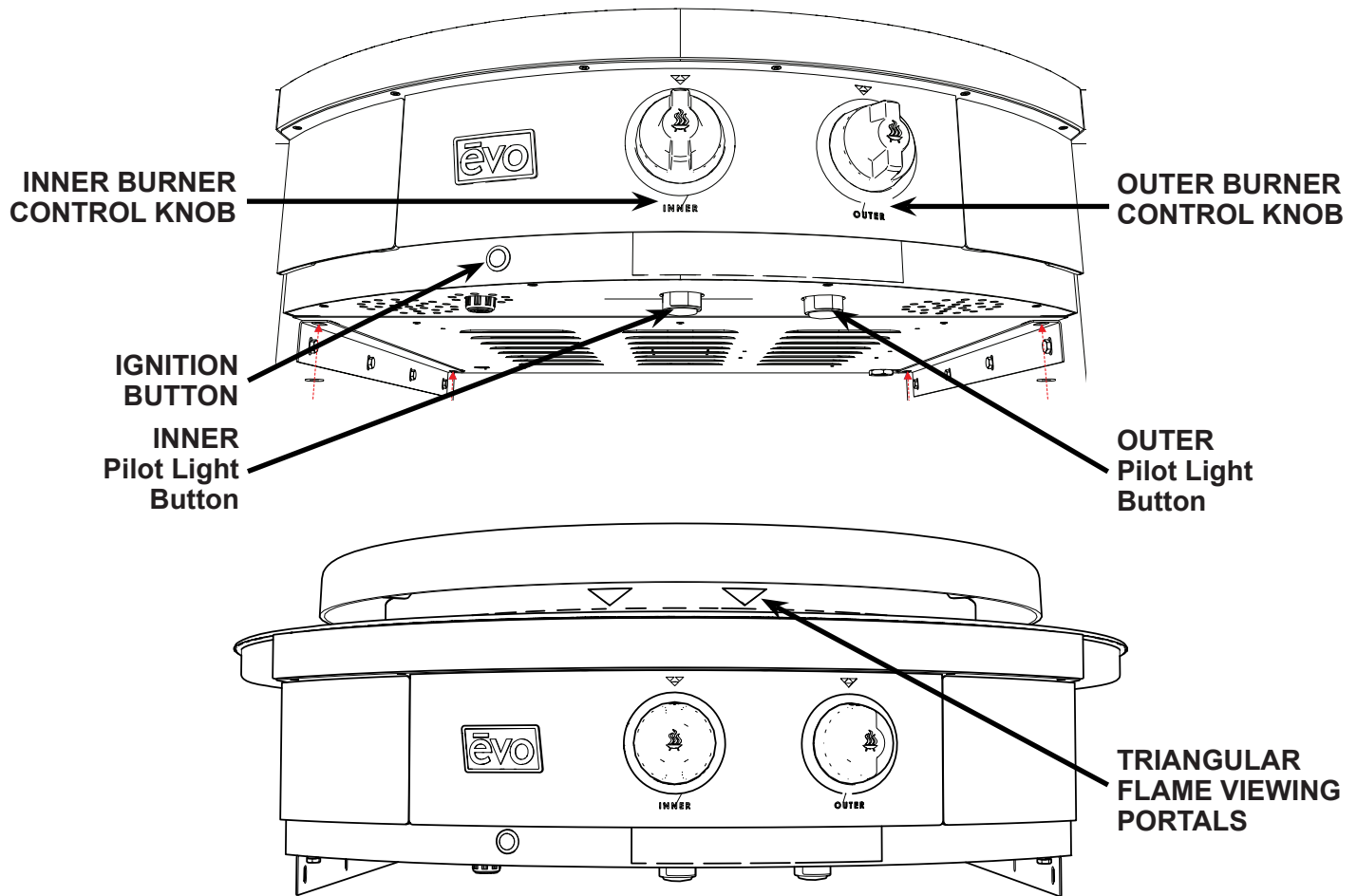

### To Light The Inner and Outer Standing Pilot Burners:

**STEP 1:** The external gas shut-off valve must be in the ON position.

**STEP 2:** Press the Ignition Button and simultaneously press the Inner Burner Pilot Light Button. It may be necessary to keep the pilot light button depressed for several minutes if air in the gas line was not bled before installation. Check to see if the gas pilot light is burning by visually inspecting through the Flame Viewing Portals for the presence of a flame. Once a flame is present, stop pressing the Ignition Button and continue pressing the pilot light button for an additional 30 seconds to 1 minute to allow the Thermocouple to become hot and the Pilot Safety Valve to open.

**STEP 3:** Once a steady flame is witnessed, release the Inner Burner Pilot Light Button and confirm the pilot light continues to burn. If the pilot light fails or extinguishes, then repeat Step 1. The most common reason for the pilot light sequence to fail is the pilot light button is not held long enough to heat the thermocouple, or there's an excess amount of air in the inlet gas line created during installation. With the pilot safety valve open, full functionality to the inner and outer burners is now available.

**STEP 4:** Repeat steps 1 and 2 for the Outer Burner Pilot Light. With both the inner and outer pilot light burners lit and continuously burning, full functionality to the inner and outer main tube burners is now available.

## TEMPERATURE CONTROL

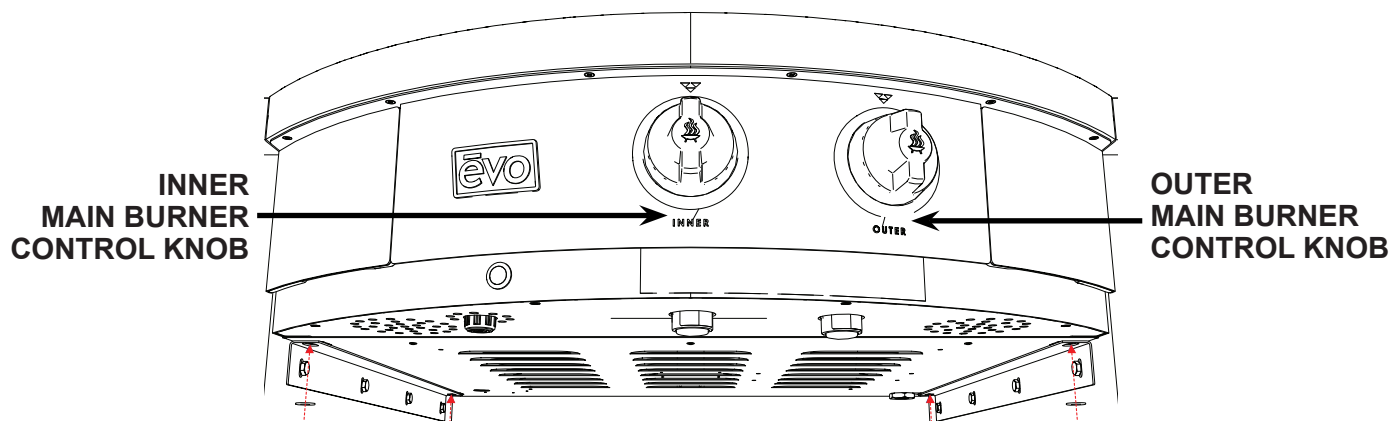

### How To Adjust Inner and Outer Temperature Control Knobs:

With both the inner and outer pilot light burners lit and continuously burning, select the inner or outer or both control knobs and choose a temperature setting between Hi, Med and Low.

To control temperature across the entire cooking surface, select an appropriate temperature based on the food being prepared using both the inner and outer control knobs. If focused temperature is required at the center of the cooking surface, choose a temperature setting using only the inner control knob, leaving the outer control knob set to Low or Off. In a similar way, if focused temperature is required at the outer diameter of the cooking surface, then choose a temperature using only the outer control knob, leaving the inner knob set to Low or Off.

### Representative Temperatures For Low, Med and Hi Control Knob Settings:

Temperature settings using both the inner and outer control knobs set to Low, Med and Hi are as follows:

Inner knob set to Lo = 237F (Outer Off), Inner knob set to Med = 310F (Outer Off), Inner knob set to Hi = 368F (Outer Off)

Outer knob set to Lo = 225F (Inner Off), Inner knob set to Med = 304F (Inner Off), Inner knob set to Hi = 405F (Inner Off)

Inner and Outer knob set to Lo = 358F, Inner and Outer knob set to Med = 450F, Inner and Outer knob set to Hi = 522F.

**Differences in altitude and inlet gas pressure less than recommended 7"W.C for NG and 11"W.C for LP will cause a variation in set temperature.**

## REMOVABLE SPILLOVER TRAYS

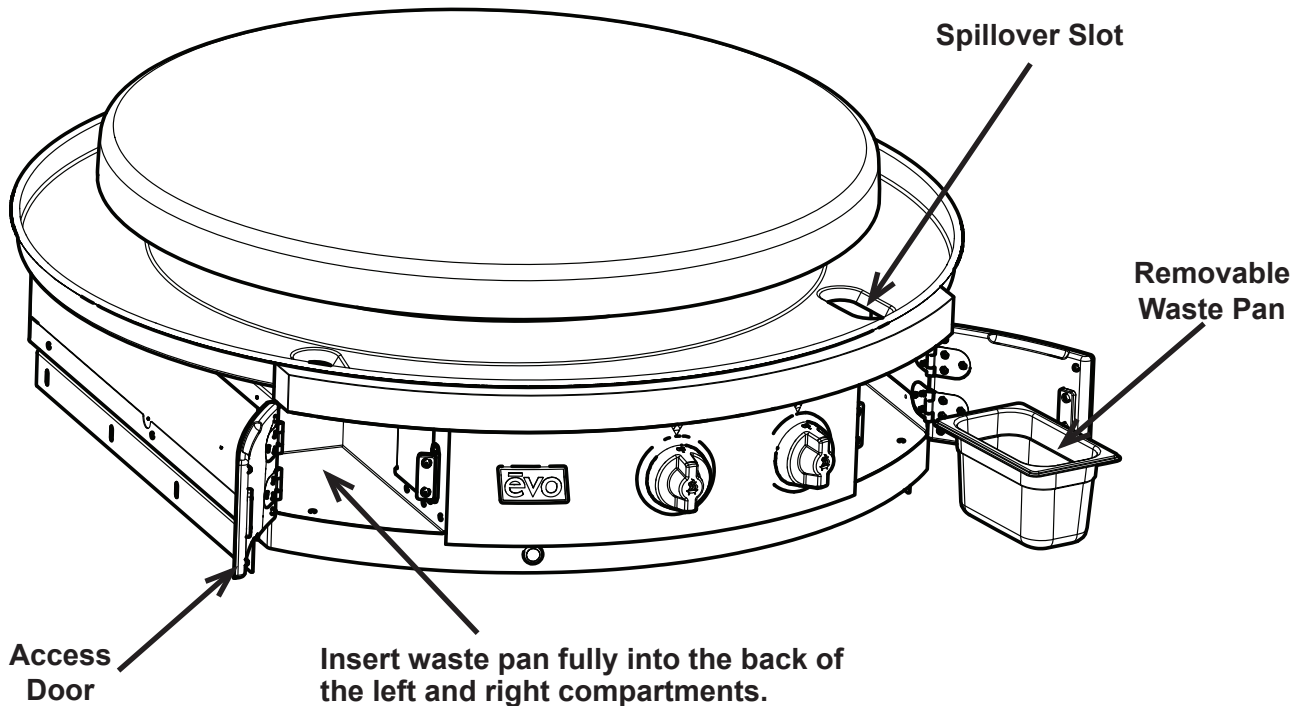

**Do not operate cook top or clean drip pan into spillover slots without waste pans installed in spillover doors. Failure to install waste pan will result in cooking grease contamination to the underside of door. This requires immediate cleaning.**

The Affinity grill has removable waste pans concealed in doors on both the right and left side of the front control panel. It is very important to monitor the level of spillover in the trays, and immediately empty when they are near full or after each use.

**Opening Spillover Tray Doors - To open a door, grasp the door at its bottom and pull forward.**



**Do not allow spillover liquids or debris down spillover slots when doors are open. Any liquids or debris that may fall into this area when doors are open should be immediately wiped with a dry cloth, and keep this area clean at all times.**



**Do not allow the spillover trays to overflow, and do not allow full trays to splash over edge when cleaning. Spillover debris and liquids can be hot and cause burns, and/or damage to the internal operation of the grill.**

## RECOGNIZING ABNORMAL GAS OPERATION

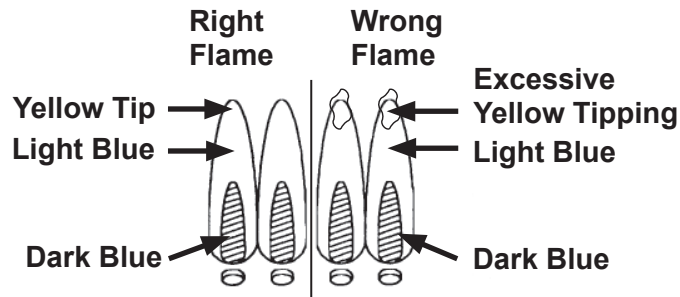

Any of the following are considered to be abnormal operation and may require servicing:

- Excessive yellow tipping of the burner flame (See diagram above).
- Sooting up of cooking utensils.
- Burners not igniting properly.
- Burners failing to remain alight.
- Gas valves, which are difficult to turn.

In case the appliance fails to operate correctly, contact the authorized service provider in your area.

### Checking Venturi Tubes:

A clogged venturi tube due to accumulated debris or lint may cause improper burner performance and difficulty lighting your grill.

To check your venturi tubes:

- Remove the bottom 'crescent-shaped' access panel just under the front control panel to access burner venturis, or alternatively remove the cooking surface and drip pan to access the valve cover located just above the center control knob.
- Remove the cover and inspect the venturi for debris or lint accumulation.
- Compressed air is the best method for removing these obstructions.



Remove the bottom 'crescent-shaped' access panel just under the front control panel to access burner venturis, or alternatively remove the cooking surface and drip pan to access the valve cover located just above the center control knob.

AFFINITY 30Gp DIMENSIONS

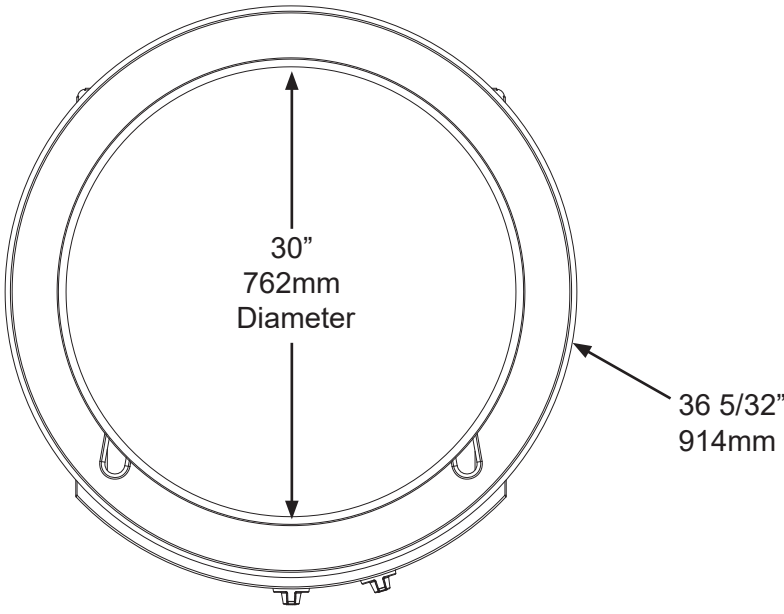

---

---

## **COOK SURFACE MAINTENANCE**

---

---

Regular cleaning and care for your Evo Affinity 30Gp cooktop will keep it looking and functioning its best.

The cook surface is designed to hold a fine layer of cooking oil creating a 'seasoning' on its surface. This seasoning promotes a non-stick cooking surface and is easily maintained.

Caring for Evo's cook surface is much like maintaining cast iron cookware. When the surface requires cleaning, there are a few basic cleaning techniques to use. For quick and routine cleaning between preparations, a metal spatula or scraper works for removing the majority of surface debris. For tougher areas or where sugars glaze the cook surface, pour a small amount of vegetable oil on the soiled surface while the grill is warm and scrape the debris away with a spatula. Heat the cook surface to a high temperature and allow the sticky debris to become brittle. Once the debris is brittle, use the spatula or scraper to remove it. Afterwards wipe the cook surface with vegetable oil again before cooking.

To condition the Evo cook surface you should use the grill cleaning kit supplied with your grill. The grill cleaning kit contains a blue grill pad handle, grill cleaning screens, and grill grey polishing pads. Use the polishing pad after the grill cleaning pads to achieve a smooth cooking surface for the most delicate foods and applications.

To use a grill cleaning screen: With a warm cook surface, place one gray polishing pad between the grill handle base and the grill screen, so the grill screen makes direct contact with the cooking surface. Pour a small amount of vegetable oil on the cook surface and scrub the surface in a circular motion. The gray polishing pad allows excess oil to be absorbed and scours the cooking surface of carbonized debris. When finished scrubbing, wipe the surface down with a paper towel or cotton terry cloth.

The stainless steel drip pan located just below the cook surface is designed to catch food debris and drippings from the cook surface. We recommend cleaning the drip pan after your grill has cooled to prevent the possibility of touching hot adjoining surfaces. The drip pan is easy to wipe out with soap and water using a kitchen sponge. For added convenience, two removable stainless spill-over pans (ninth-pan size) are mounted inside the swing open doors at right and left side of the front control panel for collecting drip pan debris and spill overs. These spillover pans are easily washed by hand or in a dishwasher. Be sure to empty the spillover pans after every use, and at a minimum, whenever they appear half full.

All the stainless steel components on your grill can be easily cleaned with soap and water and polished using a stainless steel cleaner/polish. Stainless steel cleaner can be purchased from the Evo web site along with replacement grill cleaning and polishing pads. The Evo web site address is: [www.evoamerica.com](http://www.evoamerica.com).

Thank You For Cooking With Evo!