

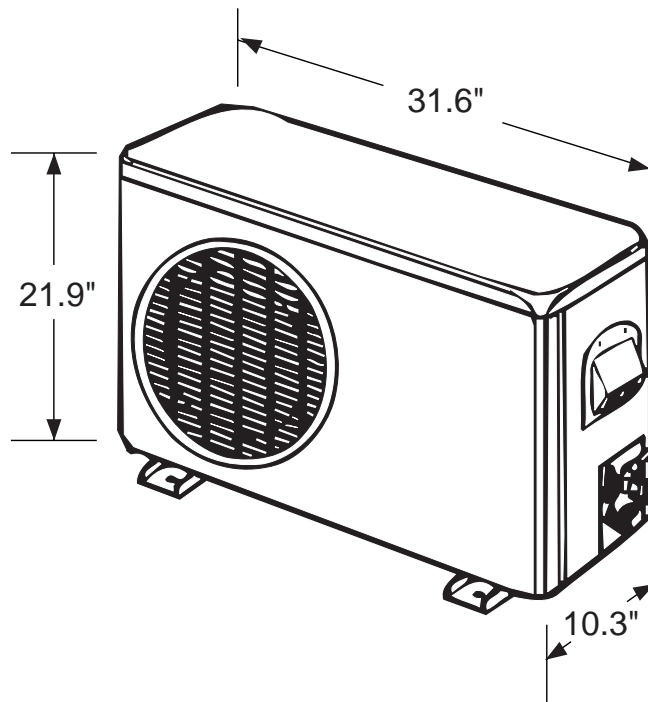

GE Appliances

AS0CD09AA0 - GE Quiet-Aire™ Ductless Split System Air Conditioner (Outdoor Component)

Dimensions (in inches)



Note: For any service which requires entry into the refrigerant sealed system, Federal regulations require that the work be performed by a technician having a Class II or Universal certification.

Optional Tube Kits

	9,000 BTU	
	TUS1542	TUS2542
Insulated Tubing	15'	25'
Wiring	30'	30'
Wall Hole Sleeve	Std.	Std.
Suction Line	0.5"	0.5"
Liquid Line	0.25"	0.25"

For answers to your Monogram,[®] GE Profile Performance Series,[™] GE Profile[™] or GE appliance questions, call GE Answer Center[®] service, 800.626.2000.



Total capacity and E.E.R. ratings are calculated based on the Association of Home Appliance Manufacturers' standards.



Listed by Underwriters Laboratories



GE Appliances

AS0CD09AA0 - GE Quiet-Aire™ Ductless Split System Air Conditioner (Outdoor Component)

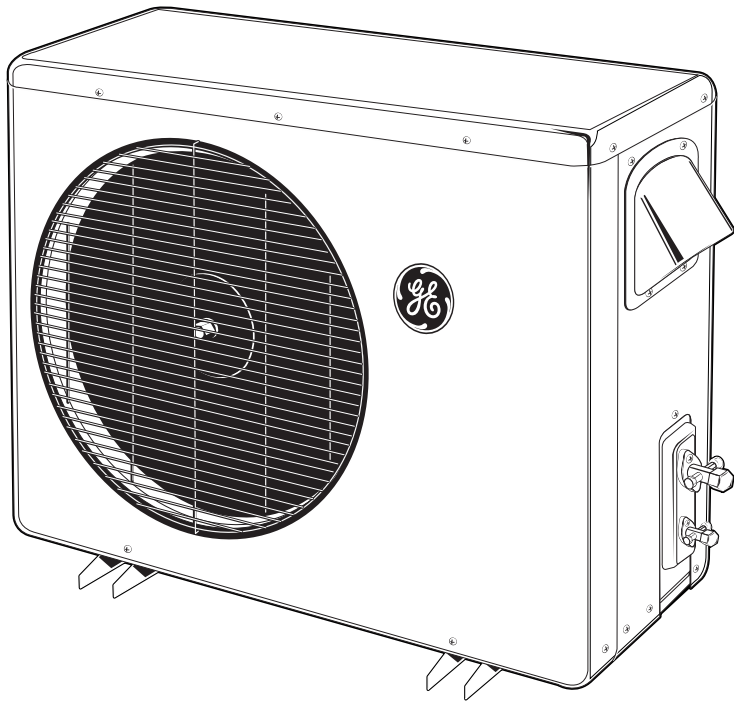

Features and Benefits

- Outdoor Ductless Air Conditioning Component with Pigeon Grey Case
- Split System Design for Quiet Operation and Flexible Installation (Both indoor and outdoor components must be purchased to complete the system)
- 9,000 BTUH Cooling Capacity, 9.6 E.E.R., 115 Volts
- Corresponding Indoor Unit Offers:
 - Auto Operation, Automatic Temperature and Fan Speed Mode Reduces Energy Consumption
 - LCD Wireless Remote Control
 - 3 Cooling / 3 Fan Speeds
 - Temperature Sensor
 - Sleep Mode
 - 24-Hour Timer (Delay Start / Pre-Set Stop)
 - Washable Air Filter
- Appropriate Tubing Kit Required to Connect Units
- AS1CD09AA0 - Indoor component
- AS0CD09AA0 - Outdoor component