

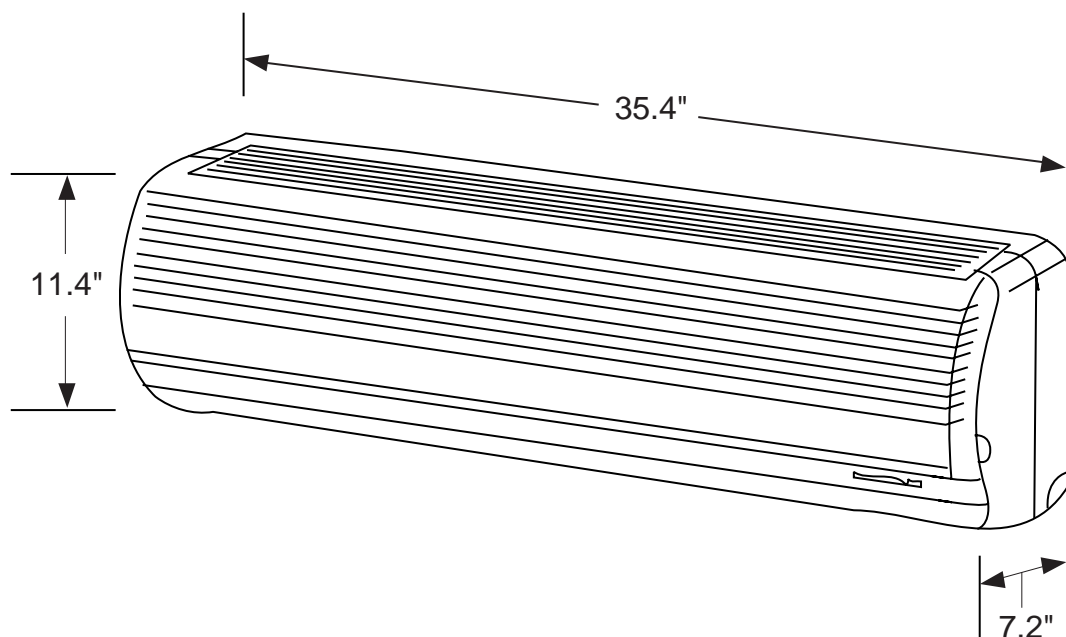

GE Appliances

AS1RD12AA0 - GE Quiet-Aire™ Ductless Split System Heat Pump (Indoor Component)

Dimensions (in inches)



Note: For any service which requires entry into the refrigerant sealed system, Federal regulations require that the work be performed by a technician having a Class II or Universal certification.

Optional Tube Kits

	12,000 BTU	
	TUS1542	TUS2542
Insulated Tubing	15'	25'
Wiring	30'	30'
Wall Hole Sleeve	Std.	Std.
Suction Line	0.5"	0.5"
Liquid Line	0.25"	0.25"

For answers to your Monogram,[®]
GE Profile Performance Series,[™]
GE Profile[™] or GE appliance questions, call
GE Answer Center[®] service, 800.626.2000.



Total capacity and E.E.R. ratings are calculated based on the Association of Home Appliance Manufacturers' standards.



Listed by Underwriters Laboratories



GE Appliances

AS1RD12AA0 - GE Quiet-Aire™ Ductless Split System Heat Pump (Indoor Component)

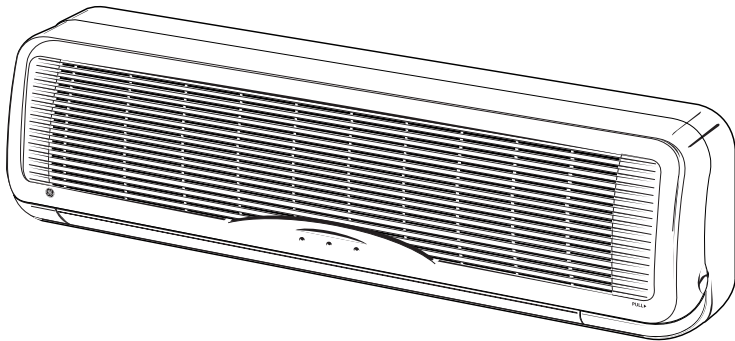

Features and Benefits

- Slim and Compact Indoor Unit with Dove White Case
- Split System Design for Quiet Operation and Flexible Installation (Both indoor and outdoor components must be purchased to complete the system)
- 12,000 BTUH Cooling and Heating Capacity, 9.3 E.E.R., 115 Volts
- Auto Operation - Automatic Temperature and Fan Speed Mode Reduces Energy Consumption
- LCD Wireless Remote Control
- 3 Cooling / 3 Heating / 3 Fan Speeds
- Temperature Sensor
- Sleep Mode
- 24-Hour Timer (Delay Start / Pre-Set Stop)
- Washable Air Filter
- Appropriate Tubing Kit Required to Connect Units
- AS1RD12AA0 - Indoor component
- AS0RD12AA0 - Outdoor component