

Café™ 1.5 Cu. Ft. Countertop Convection/Microwave Oven

CEB515M2NS5

C A F É



FEATURES & BENEFITS

Enjoy total control in the kitchen and beyond - Control your oven with your smart device or simply your voice using WiFi Connect

Achieve gourmet results with just a scan - Delegate simple cooking tasks to family members with Scan-to-Cook Technology. With just the scan of a barcode, the microwave automatically adjusts cook settings based on package instructions.

A microwave that's as versatile as you are - Achieve crisp, golden brown results with a convection cooking setting and a special rack that allows air to circulate around foods for even heat distribution

Say goodbye to guesswork - Enjoy consistently delicious results with sensor cooking controls that automatically adjust the time and power

Get that just-cooked quality anytime - Even late-arriving guests can enjoy delicious results thanks to a warming oven that keeps foods ready to serve

Let the cooking take care of itself - Take the guesswork out of preparing your favorite foods with an auto bake/auto roast feature that uses preprogrammed cooking times and temperatures

Enjoy design flexibility in your kitchen - Create more room on the countertop for meal prep with a built-in capable microwave and matching trim kit

Nice and roomy - Entertain with confidence with 1.5 cu. ft. capacity that can handle more of your favorite foods

APPEARANCE

Built-In Capability	Optional 27" Built-In Kit CX152M2NSS Optional 30" Built-In Kit CX153M2NSS
Case Color	Black
Color Appearance	Stainless Steel
Door Color	Stainless Steel
Installation	Countertop; Built-In

FEATURES

Cooking System	Turntable
Cooking Technology	Microwave/Convection
Electronic Digital Display with Clock	Yes (LED)
Express Cook	Instant-On 1-6
Instant On Controls	Yes
Microwave Watts (IEC-705)	1000W
Power Levels	10
Rack Type	2 Removable Oven Racks - Pedestal
Sound Volume Control	On/Off
Timer (On/Off)	Yes
Turntable	Glass Recessed
Turntable Size	13.5 in
Scrolling Display with Help	Yes
Convection Cooking Controls	Bake; Roast
Microwave Sensor Cooking Controls	Popcorn; Beverage; Reheat; Cook
Control Features	Control Lock; Cook Time; Clock; Timer; Add 30 Seconds; Mute; Warm; Convection Bake; Convection Roast; Combination Auto Cook; Auto Bake; Auto Roast; Auto & Time Defrost; Display On/Off; Broil
Microwave Oven Interior	Stainless Steel
Combination Cooking Controls	Combination Cook

CAPACITY

Total Capacity (cubic feet)	1.5 cu ft
Unit Capacity	Family-Size

TECHNICAL DETAILS

Electrical Input - 120V Amperage	13.0
Electrical Input - 120V Watts	1500
Frequency (MHz)	2450
Volts/Hertz	120V; 60Hz

WEIGHTS & DIMENSIONS

Approximate Shipping Weight	44 lb
Cavity (W x H x D)	15-1/2 x 10-7/8 x 15-1/2
Depth with Door Open 90°	36-7/16 in
Net Weight	38 lb
Overall Depth	20 in
Overall Height	13 in
Overall Width	21-3/4 in

WARRANTY

Parts Warranty	Limited 1-Year Entire Appliance
Labor Warranty	Limited 1-Year Entire Appliance
Warranty Notes	See Written Warranty for Full Details

Café™ 1.5 Cu. Ft. Countertop Convection/Microwave Oven



CEB515M2NS5

DIMENSIONS AND INSTALLATION INFORMATION

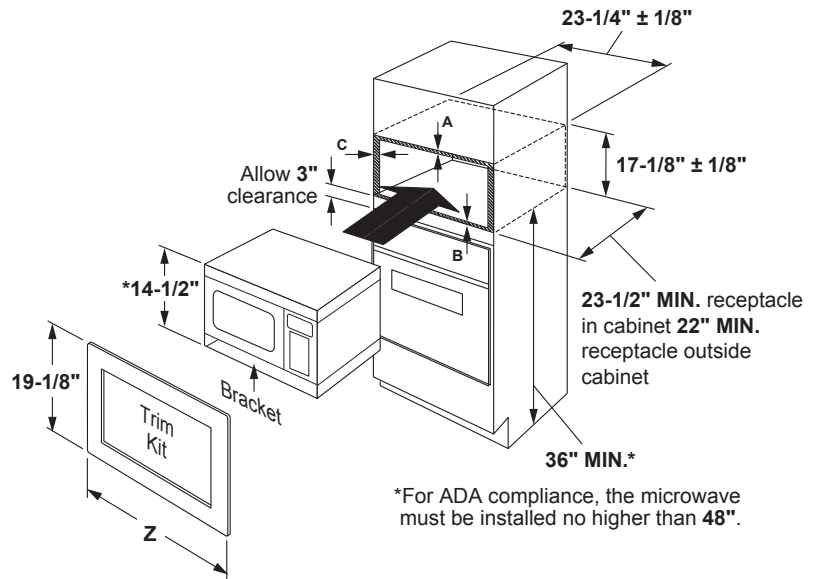
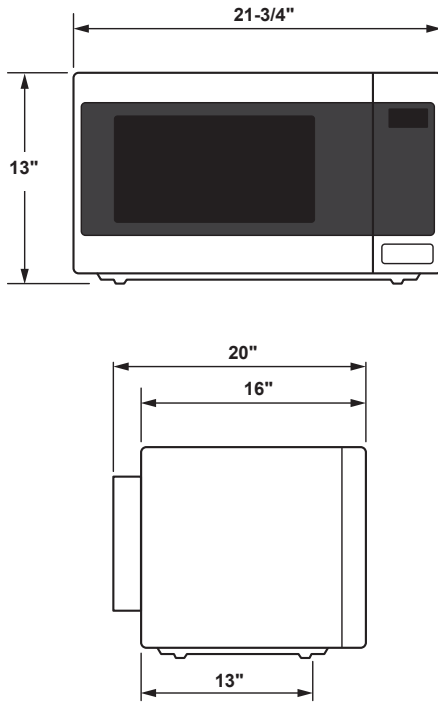

*For ADA compliance, the microwave must be installed no higher than 48".

EXTERIOR DIMENSIONS (IN INCHES)

Height	13"
Width	21-3/4"
Depth	16"
Depth Including Bumpout	20"
Depth From Back of Case to Front Legs	13"

CABINET OVERLAP REQUIREMENTS

	30"	27"
A - Overlap of Trim Kit Over Top of Cabinet	1"	1"
B - Overlap of Trim Kit Over Bottom of Cabinet	1"	1"
C - Overlap of Trim Kit Over Sides of Cabinet	3-5/16"	1-7/8"

NOTE: Allow an additional inch of clearance beyond trim kit frame on all sides.

OPTIONAL ACCESSORY TRIM KITS (AVAILABLE AT ADDITIONAL COST)

For a custom built-in appearance, these kits allow built-in installation of the countertop microwave oven into a wall or cabinet alone and are U.L. approved for installation over a GE single electric wall oven. These kits should not be installed over a gas wall oven.

Note: 120V, 60-cycle, grounded power receptacle location optional on back within cabinet opening.

Installation Information: This information is not intended to be used for installing unit described. Before installing, consult installation instructions packed with product/kit for current dimensional data.

*Height of product when installed with kit rail and bottom duct: 14-1/2"

ACCESSORY TRIM KITS	"Z"	MAX HEIGHT	TRIM KITS
30" Deluxe	29-3/4"	19-1/8"	CX153M2NS5
27" Deluxe	26-7/8"	19-1/8"	CX152M2NS5