

# Cielo

## Ceiling hood



Learn more

### MEASUREMENTS

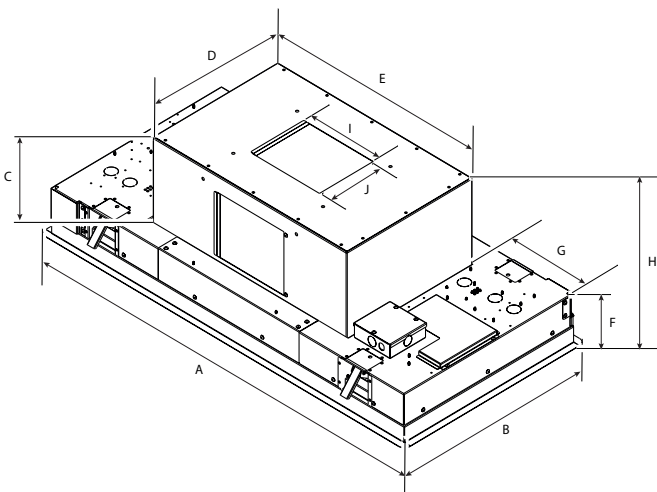

	ECEX40SS	ECEX60SS
A	40" (101 cm)	60" (152.4 cm)
B	19 7/8" (50.5 cm)	24 9/16" (62.44 cm)
C	7 5/8" (19.45 cm)	
D	13 13/16" (35.02 cm)	
E	21 5/16" (54.1 cm)	
F	4 3/8" (11.15 cm)	
G	8 1/16" (22.08 cm)	18 1/16" (47.52 cm)
H	12 1/16" (30.6 cm)	
I	7 5/16" (18.6 cm)	
J	5 15/16" (15 cm)	

### DESCRIPTION

Powerful, efficient and silent, Cielo ceiling hood consistently delivers exceptional performance across all installation modes. Sold separately is either an internal, inline or an external blower with 600 or 1200 CFM options. Only 12" of ceiling clearance is required for installation due its multidirectional ducting options. This hood will effectively extract and clean air on ceilings up to 10 ft. With its perimeter aspiration capacity and minimal sound emissions, Cielo enhances the overall kitchen environment, effectively removing vapors and maintaining a peaceful living space. Either with a Stainless Steel Finish or a Panel-ready Option for matching the ceiling design, Cielo is the perfect complement for any space.

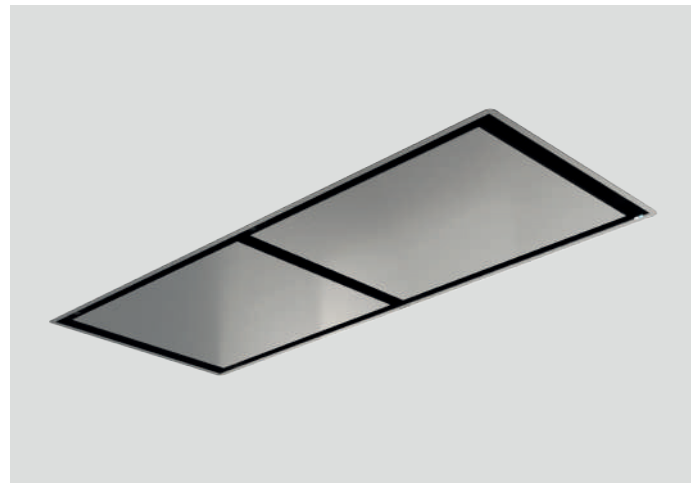

### FEATURES

-  Remote control
-  Long life filter
-  Total integration
-  Tune white
-  Perimeter aspiration
-  Dim light
-  Super easy installation
-  Panel ready



### GENERAL PROPERTIES

Width	40"	60"
Model	ECEX40SS	ECEX60SS
Dimensions	40"W x 19 7/8"D x 12 1/16"H	60"W x 24 9/16"D x 12 1/16"H
Blower Type <sup>1</sup> (Internal)	Internal, Inline or External 600 or 1200 CFM (sold separately)	
Noise (Min-max sones) <sup>1</sup>	2-8 Sones (600 CFM)/2.3-10.2 Sones (1200 CFM)	
Electrical	120V-60Hz, 578W	
Illumination	2 Strip LED, 14W, 3500 K	3 Strip LED, 14W, 3500 K
Finish	Stainless steel panel + stainless steel frame with Panel Ready Capability	
Controls (Included)	White remote control	
Grease filters	Dishwasher-safe, anodized aluminum, mesh filter + perimeter aspiration	
Duct transition	Round 6" multi directional (5 way for 600 CFM blower / 3 way for 1200 CFM blower)	
Installation type	Ducted or recirculating with kit (sold separately)	
Installation height	Can reach ceiling heights up to 10'0"	

### KITS

Recirculating	KIT0192765 (Contains 4 round carbon filters)
Optional remote control	KIT0121469 (Black) / KIT0121468 (White)
Internal Blower	KIT0198147 (600 CFM) / KIT0198146 (1200 CFM)
Inline Blower	KIT0198148 (600 CFM) / KIT0154387 (1200 CFM)
External Blower	KIT0153054 (1200 CFM)
CFM Reduction	KIT0185752 (Achieves <300 CFM for 600 CFM Blower) KIT0185099 (Achieves <400 CFM for 1200 CFM Blower)

**WARRANTY:<sup>2</sup> Two (2) Years Parts & In-Home Labor. Earn an additional One (1) Year of Parts & In-Home Labor by registering on [elica.com](http://elica.com)**



The product images shown are for illustration purposes only and may not be an exact representation of the product.  
<sup>1</sup> CFM and Noise data indicate the performance of the hood blower tested according to international standards. For AHAM Certified Ratings, established in accordance with California Title 24 Standardized test procedure, please refer to AHAM Certified Product Directory. Electric Ratings are declared according to UL.

<sup>2</sup> For valid warranty extension, register within 3 months from purchase. For USA & Canada Users Only.