

**FCMGG0055-24****FCMGG0055-36**

## **FORNO COMMERCIAL 24" and 36" HEAVY DUTY GAS GRIDDLE, MANUAL CONTROL**

**FCMGG0055-24  
FCMGG0055-36**



ANSI Z83.11 • CSA 1.8-(2016) Food Service Equip.  
Conforms to ANSI STD Z83.11-2016  
Certified to CSA STD 1.8-2016 Food Service Equip.  
CONFORMS TO NSF/ANSI 4:2020

# **INSTRUCTION MANUAL**

Read these instructions carefully before using your appliance, and keep it carefully.  
If you follow the instructions, your appliance will provide you with many years of good service.

## TABLE OF CONTENTS

Customer Care	4
Important Safety Notice	5
Attention Owners and Operators	6
Unpacking & Installation	7
Warnings and Safeguards for Operation	9
Operating Instructions	10
Cleaning Instructions	12
Troubleshooting	13
Conversion Kit Instructions for Gas Countertop Griddle	14
Gas Countertop Griddle Model	16
Warranty	17

**FORNO COMMERCIAL 24" and 36" HEAVY DUTY  
GAS GRIDDLE, MANUAL CONTROL**



**FCMGG0055-24**



**FCMGG0055-36**

## Customer Care

Thank you for purchasing a Forno product. Please read the entire instruction manual before operating your new appliance for the first time. Whether you are an occasional user or an expert, it will be beneficial to familiarize yourself with the safety practices, features, operation and care recommendations of your appliance.

Both the model and serial number are listed inside the product. For warranty purposes, you will also need the date of purchase .

Record this information below for future reference.

Product Information	Service Information
Model Number : _____	
Serial Number : _____	
Date of Purchase : _____	
Purchase Address And Phone: _____ _____ _____	

**Service Information**

Use these numbers in any correspondence or services calls concerning your product.

If you received a damaged product, immediately contact Forno.

To save time and money, before you call for serviced, check the troubleshooting guide. It listed the causes of minor operation problems that you can correct yourself.



*“Need some quick help? Simply scan the qr code and get access to our fast support form. We’re always here to assist you with any questions or concerns you may have. So, don’t hesitate to reach out!”*

### Services in Canada and Untied States

Keep the instruction manual handy to answer your questions. If you don’t understand something or need more assistance, please visit our website for fast support. Please provide us your name, number, address,serial number of the product that troubleshooting, proof of purchase, and a short description of the issue. A customer service representative will contact you as soon as possible. All warranty work needs to be authorized by FORNO customer service. All our authorized service providers are carefully selected and rigorously trained by us.

# IMPORTANT SAFETY NOTICE

This manual contains important safety instructions which must be strictly followed when using this equipment.

**Please retain this manual for future reference.**

Instructions must be posted in a prominent location. All safety precautions must be taken in the event the user smells gas. Safety information can be obtained from your local gas supplier.

## FOR YOUR SAFETY

*Do not store or use gasoline or other flammable vapors or liquids in the vicinity of this or any other appliance.*

**WARNING:** Improper installation, adjustment, alteration, service or maintenance can cause property damage, injury or death. Read the installation, operating and maintenance instructions thoroughly before installing or servicing this equipment.

# Attention Owners and Operators

Equipment is designed to provide safe and productive processing, cooking and warming of food products as long as the equipment is used in accordance with the instructions in this manual and is properly maintained. Unless the operator is adequately trained and supervised there is a possibility of serious injury. Owners of this equipment bear the responsibility to make certain that this equipment is used properly and safely, and to strictly follow all of the instructions contained in this manual and the requirements of local, state or federal law.

Owners should not permit anyone to touch this equipment unless they are over 18 years old, are adequately trained and supervised, and have read and understood this manual. Do not attempt to repair or convert any gas types on your own. Repairs and conversions are to be made solely by an authorized servicer. Owners should also ensure that no customers, visitors or other unauthorized personnel come in contact with this equipment. Please remember that venter cannot anticipate every circumstance or environment in which its equipment will be operated. It is the responsibility of the owner and the operator to remain alert to any hazards posed by the function of this equipment. If you are ever uncertain about a particular task or the proper method of operating this equipment, ask your supervisor.

This manual contains a number of precautions to follow to help promote safe use of this equipment. Throughout the manual you will see additional warnings to help alert you to potential hazards.

**Warnings affecting your personal safety indicated by:**



or



**Warnings affecting your possible damage to the equipment and property are indicated by:**



If any warning labels or this manual are misplaced, damaged, or illegible, or if you require additional copies, please contact your nearest representative or supplier directly for these items at no charge.

Please remember that this manual or the warning labels do not replace the need to be alert, to properly train and supervise operators, and to use common sense when using this equipment.

<b>Model</b>	<b>Gas</b>	<b>Number Of Burners</b>	<b>BTU Input Rating</b>
24" Griddle	Natural / LP	2	60,000
36" Griddle	Natural / LP	3	90,000

# Unpacking & Installation



## WARNING

### TO AVOID SERIOUS PERSONAL INJURY AND PROPERTY DAMAGE:

- ALWAYS install equipment in a work area with adequate light and space.
- ONLY operate on a solid, level, nonskid surface that is nonflammable and away from sinks and water hazards.
- NEVER bypass, alter or modify this equipment in any way from its original condition. Doing so may create hazards and will void warranty.

## GAS and GAS PRESSURE



### CAUTION

This unit is factory supplied in Natural Gas. This unit can be converted to L.P. gas by a licensed and certified gas technician, Documentation may be necessary for warranty issues Failure to comply with this instruction, will void warranty. See the included L.P. conversion kit for gas conversion parts and instructions.



### WARNING

Installation must conform with the National Fuel Gas Code, ANSI Z223.1/NFPA 54, the National Gas Installation Code, CSA-B149.1, or the Propane Installation Code, CSA-B149.2 as applicable and in accordance with local codes.



### WARNING



The appliance and it's individual shutoff valve (to be supplied by user) must be disconnected from the gas supply piping system during any pressure testing of that system at test pressures in excess of ½ psi (3.45 kPa).



These models are designed, built, and sold for commercial use only.

## UNPACKING

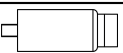
Unpack the Griddle immediately after receipt. Remove the gas Griddle from the crate; remove all packaging on and surrounding the unit and be certain to remove all protective plastics and residues from all surfaces. Make sure that all parts provided including the L.P. gas conversion kit are located. Equipment must have the legs properly installed before use.

If the machine is found to be damaged, save the packaging material and contact the carrier within fifteen (15) days of delivery. Immediately contact vender or your local dealer of the equipment. **You have no recourse to damage after fifteen (15) days.**

No.	Accessory	Q'TY	Fig
1	Adjustable feet	4	
2	Regulators	1	
3	FCMGG0055-24 orifice	2	

No.	Accessory	Q'TY	Fig
4	FCMGG0055-36 orifice	3	
5	tray	1	

# Unpacking & Installation

## INSTALLATION

1. Read this manual thoroughly before installation and operation. DO NOT proceed with installation and operation if you have any questions or do not understand anything in this manual. Contact your local representative first.

2. Select a location for the Griddle that has a level, solid, nonskid surface that is nonflammable and away from water hazards or sinks, and is in a well-lighted work area away from children and visitors.

3. Equipment must be installed under proper ventilation as required per local code.

**NOTICE: Local codes regarding installation and ventilation vary greatly by area. The National Fire Protection Association, Inc, states that local codes are “authority having jurisdiction” when it comes to requirements for installation of equipment. Therefore, installation should comply with all local codes.**

4. This appliance is equipped for Natural gas, for conversion to LP gas please see another conversion kits instruction.

5. Screw legs into the permanently fastened nuts on the four corners of the unit and tighten by hand. Legs must be installed to adequately provide proper ventilation to the unit.

6. Level unit by adjusting the four feet and tighten securely. The adjustable feet have an adjustment of one inch for lineup with other countertop lines. Do not slide unit with legs mounted, lift if necessary to move unit.

7. The supplied gas pressure regulator is factory set at 4" Natural gas W.C. or 10" for L.P.

8. THESE UNITS ARE SUITABLE FOR INSTALLATION ON NON-COMBUSTIBLE SURFACES ONLY. Noncombustible clearances: 0" sides (0mm) 6" rear (152 mm) 4" floor (102 mm)

9. Do not obstruct the flow of combustion and ventilation air, under the unit by the legs or behind the unit by the flue. Do not place objects between the bottom of the unit and the counter top.

10. There must be adequate clearance for removal of the front panel. All major parts except the burners are removable thru the front if the gas line is disconnected.

11. It may be necessary to adjust the balance of gas volume and air supply to each burner. This must be done by an authorized service technician.

12. Pipe threading compound must be resistant to the action of liquefied petroleum gases.



DO NOT use an open flame to check for leaks. Check all gas piping for leaks with a soap and water solution before operating unit.

## COMMISSIONING

Commissioning of your new Griddle is of the utmost importance. Commissioning is the thorough and methodical testing of the equipment, sub systems, and systems to ensure that the final product functions properly and safely at the work site. By identifying any potential problems (i.e.: equipment location, ventilation, local fire/electrical codes, installation, operator training and certification) prior to equipment being placed into service, costly outages and potential damages may be avoided.

# Warnings and Safeguards for Operation



## TO AVOID SERIOUS PERSONAL INJURY AND PROPERTY DAMAGE:



For your safety, do not store or use gasoline or other flammable vapors or liquids in the vicinity of this or any other appliances. Keep the area free and clear of combustible. (See ANSI Z83. 14B, 1991).



Improper installation, adjustment, alteration, service or maintenance of this equipment can cause property damage, personal injury, or death and voids warranty. Read the installation operating and maintenance instructions thoroughly before installing, or operating this equipment.



Instructions must be posted in a prominent location. All safety precautions must be taken in the event the user smells gas. If you smell gas, immediately shut off the main gas valve, extinguish all heat and flames, and call 911. Safety information can be obtained from your local gas supplier.

## IMPORTANT SAFEGUARDS & SAFETY INSTRUCTIONS



When using gas cooking equipment, basic safety precautions should always be followed, including the following:

The Griddle outside surfaces may become HOT after use. Use caution when touching the unit.

- Never directly touch the burners or cooking grates while the Griddle is on.
- Always turn off the unit when not in use, servicing or adjusting any parts or attachments, and before cleaning.
- Never leave the Griddle on overnight.
- Do not operate any equipment with a damaged or leaking gas line, ignitor or valves or if the unit is dropped or damaged in any manner. Call for service.
- The use of attachments not recommended or sold by the manufacturer may cause fire, injury or even death.
- Do not use outdoors.
- Do not use this equipment for any use other than the use intended by the manufacturer.
- Never use the Griddle as a heating source
- The Griddle does not contain any user-serviceable parts. Dealers or recommended qualified technicians should carry out repairs. Do not remove any components or service panels on this product.
- Never bypass, alter, modify or attach any unauthorized parts to this equipment. Doing so may create hazards and will void warranty
- Vender takes every care to ensure that all products are safe. Steel cutting procedures used to manufacture these items result in sharp edges. These sharp edges are removed to the best of our ability; however, we insist the operator take care when in contact with this piece of equipment.
- Always keep hands, hair and clothing away from heating source.
- Allow the Griddle to cool down after use and before dismantling for cleaning; the unit will be too hot to handle immediately after use.

# Operating Instructions

## Operating the Griddle - Pilot Lighting Instructions for MANUALLY CONTROLLED Griddles

Before operating Griddle, it should be checked to see that it is sitting level. Adjust the feet to level the Griddle. Be sure the catch tray has been properly placed.

The pilot light on the appliance have been set at the factory. Each burner has a pilot light.

1. Make sure all knobs are in the "OFF" position.
  2. The main gas valve should be "CLOSED/OFF" for five (5) minutes prior to lighting pilots to clear any existing gas. (Main gas valve is supplied by others.)
  3. Turn "ON/OPEN" the main gas valve to the unit.
  4. Light and hold an ignition source (match) at the pilots. When the flame is established, remove the ignition source. Repeat this step for each burner as each burner has its own individual pilot.
- The pilot can be reached through the holes in the front of the unit.
5. Adjust the pilot valve, make sure the pilot flame at 1/2 inch height.
  6. Turn each burner knob "ON". If the burners do not ignite promptly, turn the knobs "OFF". From the opening in the front panel, use a screwdriver and turn the pilot valve screw counterclockwise which will increase the flame height and repeat step 4.

If the pilot flame appears larger than necessary, turn it down and reset burner ignition. The pilot flames should be as small as possible but large enough to guarantee reliable ignition of the burners when the knobs are turned to "ON". The holes located in the front panel are pilot valve adjustments. Use a screwdriver to turn the valve to adjust the flame height to your desired level.



**WARNING**

All burners are lit from constantly burning pilots. Turning the valve to the desired flame height is all that is required to put the unit in service

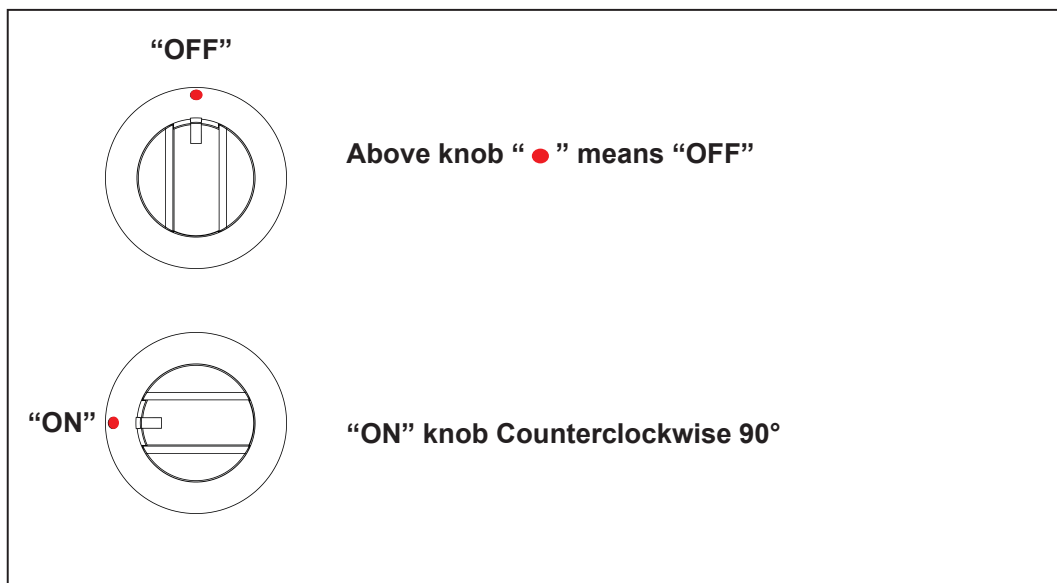

# Operating Instructions

## **Igniting the Burner**

To ignite the burner, turn knob to the “ON” position. Then back off to the desired flame level. The range of adjustment is virtually infinite between “ON” and “OFF”.

The space between the legs at the bottom admits combustion air. **DO NOT BLOCK THIS SPACE.**

All burners are lit from constantly burning pilots. Turning the valve to the desired flame height is all that is required to put the unit in service.

Do not permit fans to blow directly at the unit. Wherever possible, avoid open windows next to the unit’s sides or back. Avoid wall type fans which create air cross-currents within a room.

It is also necessary that sufficient air should be allowed to enter the room to compensate for the amount of air removed by any ventilating system. Otherwise, a subnormal atmospheric pressure will occur, affecting operation and causing undesirable working conditions.

A properly designed and installed hood will act as the heart of the ventilating system for the room or area in which the unit is installed, and will leave the unit independent of changing draft conditions.

NOTE: It may be necessary to adjust the balance of gas, volume and air supply to each burner. This must be done by an authorized service technician.

## **Seasoning the Griddle**

Heat to low temperature (300 - 350 F/150-180C) and pour small amount of cooking oil to the griddle plate (about one ounce (30cc) per square foot of surface). Spread the oil over the entire griddle surface with a cloth to create a thin film. Wipe off any excess oil with a cloth. Repeat this procedure 2 to 3 times until the griddle has a slick, mirror-like surface.

## **Operating the Griddle**

Turn the burners on about 15-20 minutes before cooking for preheating. Set the knobs to the desired flame height or temperature. Each valve controls the gas flow to the burner to bring that area of the unit up to the set temperature.

If different temperature settings are to be used, adjoining areas should be set at progressively higher temperatures using the lowest temperatures on the outside burners. A uniform and systematic approach to the loading of the unit will produce the most consistent product results.

## **Shutdown burner**

To turn 'OFF' the appliance completely, turn the gas control knob completely clockwise to the 'O' position, the pilot burner will extinguish.

# Cleaning Instructions



**DO NOT use any abrasive or flammable cleaning fluids.**

**DO NOT hose down, immerse or pressure wash any part of the Griddle, excluding the catch tray.**

**NEVER use a scrubber pad (on all exterior surfaces, except the griddle plate), steel wool or abrasive material, or cleaners containing chlorine, iodine and ammonia or bromine chemicals as these will deteriorate the stainless steel and shorten the life of the unit.**



**IF CLEANING ALL THE GRIDDLE'S SURFACES, THE MAIN GAS VALVE MUST BE SWITCHED TO THE CLOSED POSITION. AFTER CLEANING, THE GAS LINE CAN BE SWITCHED BACK TO THE OPEN POSITION. PLEASE FOLLOW THE LIGHTING INSTRUCTIONS IN THIS MANUAL TO RELIGHT THE GRIDDLE'S PILOT LIGHTS AS NEEDED.**

## RECOMMENDED CLEANING

It takes very little time and effort to keep the Griddle attractive and performing at top efficiency. Wait until the griddle is cool after the unit has been turned off. Please follow the cleaning steps below:

PART	REQUIRED ACTION	FREQUENCY
Body	Use a clean cloth and a non-abrasive cleaner to clean the stainless steel body of the Griddle. Wipe the polished areas with a soft cloth.	Daily
Back and Side Splashes	Thoroughly clean. Wipe with clean, warm, mildly soapy water then wipe splashes with a damp cloth.	Daily
controls	Unit should be turned off when not in use.	Daily
	It is recommended that the unit be disconnected from the gas supply by closing the main gas valve.	
	Use a clean cloth to wipe any down controls and/or knobs	
Griddle Plate	Clean surface with wire brush or metal spatula. Clean the griddle surface thoroughly. If necessary, use a griddle stone, wire brush or steel wool on the surface. • Rub with the grain of the metal while the griddle is still warm. A mild soap may be used on the plate surface to help clean it • Remove all soap and debris thoroughly; wipe with a clean, damp cloth. • The plate should then be covered with a thin film of oil to prevent rusting. Clean stainless surfaces with a damp cloth and polish with a soft dry cloth. To remove discoloration, use a nonabrasive cleaner. After each "weekly" cleaning, the griddle must be seasoned again. If the griddle usage is very high, the "weekly" cleaning procedures may be done more often than once a week.  DO NOT put ice on the griddle plate as this may damage the plate.	After each use Weekly
Catch Tray	Once the unit has cooled, remove the catch tray and discard the waste, grease/debris and crumbs. CAUTION: If the catch tray is permitted to fill too high, grease/debris is likely to accumulate under the unit. The catch tray/drawer is removed by pulling forward. USE CAUTION WHEN REMOVING!	per Use or at least Daily

# Troubleshooting

ISSUE	CAUSE	SOLUTION
Griddle not lighting	Main gas line is closed	Open valve
	Pilot light is not lit	Ignite pilot light
	Cause unknown	Call for service
Flame is too high or too low	Adjustment knob is turned up or down	Adjust flame with control knob
Pilot light not staying lit	Flame is too low	Adjust pilot light flame height
	Pilot tube clogged	Replace pilot tube. Call for service
Strong smell of gas in cooking area	Main gas line leak	Turn off main gas valve. <b>DO NOT LIGHT FLAME</b> , ignite anything, or turn/switch on anything electrical Call fire department if needed and call for service
Cooking surface is heating up slowly	Carbon build up	Clean unit
	Cause unknown	Call for service
Gas type of Unit needs to be converted	Unit ships from the factory Natural gas. Conversion from Natural Gas to L.P. is possible for this unit	Contact an authorized servicer or vender. Do not attempt conversion on your own

If problems persist and the assigned solution does not remedy the issue, please call Service Department or your local service company.



# Conversion Kit Instructions for Gas Countertop Griddle

## IMPORTANT SAFETY NOTICE

These conversion instructions are for conversion of the GAS GRIDDLE. The instructions provide in this kit are for the conversion of Natural Gas to L.P. gas and refer to the conversion of the unit and kit provided. An authorized licensed technician must be called to perform the complete conversion of the unit. Failure to properly convert this unit, can result in serious injury, property damage or death and will void warranty.

## Griddle Conversion Kit Instructions



Do not attempt gas conversion by yourself. Gas conversion of your unit is to be made by a certified/licensed technician.

### CONVERSION

Instructions are for conversion from Natural Gas to Propane (L.P.) on all models. The conversion should be done before connecting the unit to the gas supply. Units are shipped from the factory equipped for use on natural gas. Parts necessary for L.P. (liquid propane) are provided with the unit. Turn off the main gas supply before doing any maintenance.

1. Remove 4 screws of panel, take off panel and all knobs

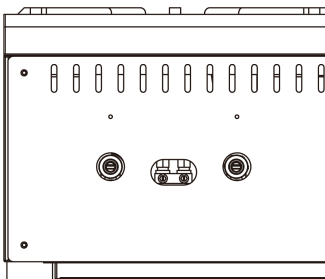

2. Take off a nut on the device bottom, it's fix nut on U shape burner

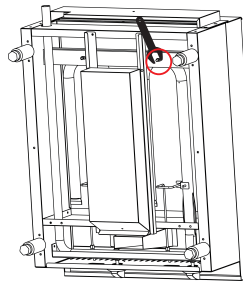

3. Raise up and pull backward on U burner, can see the orifice on the front.

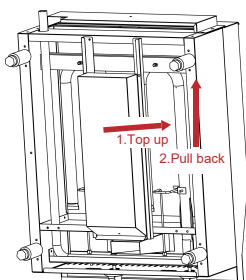

4. Replace the orifice and lock it.  
Note: number on side of orifice.

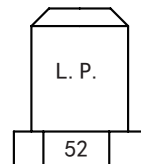
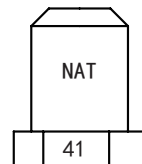
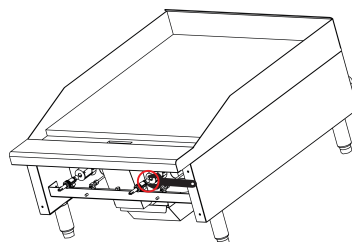

## Conversion Kit Instructions for Gas Countertop Griddle(continued)

5. Put U burner on original position, and lock nut.

6. Before installing the included convertible regulator, unscrew the octagon cap. You can read (NAT) on the plastic insert attached to the head of the cap; flip it over and snap back in place.

Pictured is the plastic insert. Pull off insert from octagon cap and reverse the plastic insert position so that the L.P. position is attached to the octagon cap head.

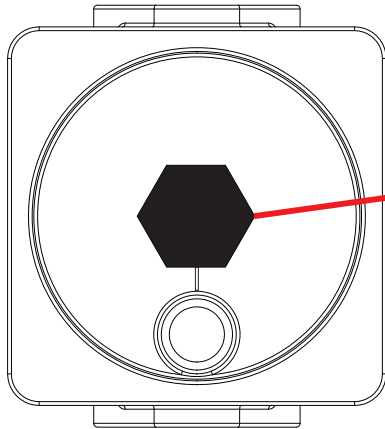

Convertible regulator with octagon cap. Unscrew from regulator.

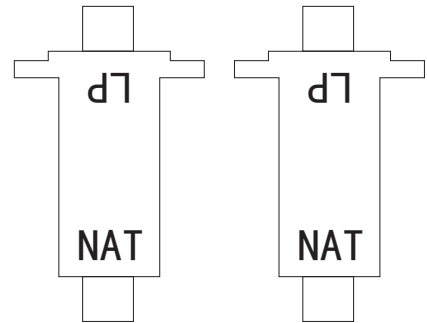

L.P. Position of insert. Regulator is now converted to L.P.

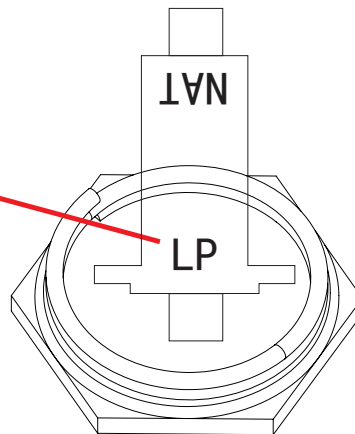

L.P. Position

7. Check all joints in the gas supply line for leaks. use soap and water solution. do not use an open flame.

8. Install knobs and panel follow above steps.

# Gas Countertop Griddle Model

A product with the FORNO the best in durability and low maintenance. We allrecoanize, however, that replacement parts and occasional professional service may be necessaryto extend the useful life of this unit. When service is needed, contact aAuthorized ServiceAgency, or your dealer. To avoid confu- sion, always refer to the model number, serial number, andtype of your unit.



---

**Intertek**



---

**Intertek**

## Warranty

---

### What this limited warranty covers:

The Warranty coverage provided by Forno Appliances in this statement applies exclusively to the original Forno appliance ("Product") sold to the consumer ("Purchaser") by an authorized Forno dealer/distributor/retailer, purchased and installed in the United States or Canada, and which has always remained within the original country of purchase (the United States or Canada). Warranty coverage is activated on the date of the Product's original retail purchase and has a duration of two (2) years. Warranty coverage is non-transferable. In the event of replacement of parts or of the entire product, the replacement Product (or parts) shall assume the remaining original Warranty activated with the original retail purchase document. This Warranty shall not be extended with respect to such replacement. Forno Appliances will repair or replace any component/part which fails or proves defective due to materials and/or workmanship within 2 years of the date of the original retail purchase and under conditions of ordinary residential, non-commercial use. Repair or replacement will be free of charge, including labor at standard rates and shipping expenses. Purchaser is responsible for making the Product reasonably accessible for service. Repair service must be performed by a Forno Authorized Service company during normal working hours.

### Important

Retain proof of original purchase to establish warranty period. Forno's liability on any claim of any kind, with respect to the goods and/or services provided, shall in no event exceed the value of the goods or service or part thereof which has given rise to the claim.

### 30-Day Cosmetic Warranty

The Purchaser must inspect the product at the time of delivery. Forno warrants that the Product is free from manufacturing defects in materials and workmanship for a period of thirty (30) days from date of the original retail purchase of the Product.

This coverage includes:

Paint blemishes  
Chips  
Macroscopic finish defects

### Cosmetic warranty does NOT cover:

Issues resulting from incorrect transport, handling and/or installation (e.g.: dents, broken, warped or deformed structures or components, cracked or otherwise damaged glass components);  
Slight color variations on painted/enamelled components;  
Differences caused by natural or artificial lighting, location or other analogous factors; > stains/corrosion/discoloration caused by external substances and/or environmental factors; > labor costs, display, floor, B-stock, out-of-box, "as is" appliances and demo units.

### How to receive service

To receive warranty services, the Purchaser must contact the Forno Support department in order to determine the problem and the required service procedures. Troubleshooting with

a customer service representative will be necessary before moving forward with the service. Model number, serial number and date of original retail purchase will be requested.

### Warranty Exclusions: What Is Not Covered.

- Use of the Product in any non-residential, commercial application.
- Use of the Product for anything other than its intended purpose.
- Repair services provided by anyone other than a Forno Authorized Service agency.
- Damages or repair services to correct services provided by unauthorized parties or the use of unauthorized parts.
- Installation not in accordance with local/state/city/county fire codes, electrical codes, gas codes, plumbing codes, building codes, laws or regulations.
- Defects or damage due to improper storage of the Product.
- Defects, damage or missing parts on products sold out of the original factory packaging or from displays. > Service calls or repairs to correct an incorrect installation of the Product and/or related accessories.
- Replacement of parts/service calls to connect, convert or otherwise repair the electrical wiring and/or gas line in order to properly use the product.
- Replacement of parts/service calls to provide instructions and information on the use of the Product.
- Replacement of parts/service calls to correct issues arising from the product being used in a manner other than what is normal and customary for residential use.
- Replacement of parts/service calls due to wear and tear of components such as seals, knobs, pan supports, shelving, cutlery baskets, buttons, touch displays, scratched or broken ceramic-glass tops.
- Replacement of parts/service calls for lack of/improper maintenance, including but not limited to: build up of residues, stains, scratches, discoloration, corrosion.
- Defects and damages arising from accidents, alteration, misuse, abuse or improper installation.
- Defects and damages arising from Product transport, logistics and handling. Inspection of the product must be made at time of delivery. Following receipt and inspection, the selling dealer/delivery company must be notified of any issues arising from handling, transport and logistics.
- Defects and damages arising from external forces beyond the control of Forno Appliances, including but not limited to wind, rain, sand, fires, floods, mudslides, freezing temperatures, excessive moisture or extended exposure to humidity, power surges, lightning, structural failures surrounding the appliance and other acts of God.
- Products whose serial number has been altered/damaged/tampered with. In no case shall Forno be held liable or responsible for damage to surrounding property, including furniture, cabinetry, flooring, panels, and other structures surrounding the Product. Forno is neither liable nor responsible for the Product if it is located in a remote area or an area where certified trained technicians are not reasonably available. Purchaser must bear any transportation and delivery costs of the Product to the nearest Authorized Service Center or the additional travel expenses of a certified trained technician

## **Warranty (continued)**

---

THERE ARE NO EXPRESS WARRANTIES OTHER THAN THOSE LISTED AND DESCRIBED ABOVE, AND NO WARRANTIES, EITHER EXPRESS OR IMPLIED, INCLUDING, BUT NOT LIMITED TO, ANY IMPLIED WARRANTIES OF MERCHANTABILITY OR FITNESS FOR A PARTICULAR PURPOSE THAT SHALL APPLY AFTER THE EXPRESS WARRANTY PERIODS STATED ABOVE, AND NO OTHER EXPRESS WARRANTY OR GUARANTEE GIVEN BY ANY PERSON, FIRM OR CORPORATION WITH RESPECT TO THIS PRODUCT SHALL BE BINDING ON FORNO. FORNO SHALL NOT BE LIABLE FOR LOSS OF REVENUE OR PROFITS, FAILURE TO REALIZE SAVINGS OR OTHER BENEFITS, TIME AWAY FROM WORK, MEALS, LOSS OF FOOD OR BEVERAGES, TRAVELING OR HOTEL EXPENSES, EXPENSES TO RENT OR PURCHASE APPLIANCES, REMODELING/CONSTRUCTION EXPENSES IN EXCESS OF DIRECT DAMAGES WHICH ARE UNDENIABLY CAUSED EXCLUSIVELY BY FORNO OR ANY OTHER SPECIAL, INCIDENTAL OR CONSEQUENTIAL DAMAGES CAUSED BY THE USE, MISUSE OR INABILITY TO USE THIS PRODUCT, REGARDLESS OF THE LEGAL THEORY ON WHICH THE CLAIM IS BASED, AND EVEN IF FORNO HAS BEEN ADVISED OF THE POSSIBILITY OF SUCH DAMAGES. NOR SHALL RECOVERY OF ANY KIND AGAINST FORNO BE GREATER IN AMOUNT THAN THE PURCHASE PRICE OF THE PRODUCT SOLD BY FORNO AND CAUSING THE ALLEGED DAMAGE. WITHOUT PREJUDICE TO THE FOREGOING, PURCHASER ASSUMES ALL RISK AND LIABILITY FOR LOSS, DAMAGE OR INJURY TO PURCHASER AND PURCHASER'S PROPERTY AND TO OTHERS AND THEIR PROPERTY ARISING FROM THE USE, MISUSE, OR INABILITY TO USE THIS PRODUCT SOLD BY FORNO THAT IS NOT A DIRECT RESULT OF NEGLIGENCE ON THE PART OF FORNO THIS LIMITED WARRANTY SHALL NOT EXTEND TO ANYONE OTHER THAN THE ORIGINAL PURCHASER OF THIS PRODUCT, IS NON-TRANSFERABLE, AND STATES YOUR EXCLUSIVE REMEDY.



FOR  
**FAST SUPPORT**  
EMAIL AT [INFO@FORNO.CA](mailto:INFO@FORNO.CA) 

Customer Support: Call 1-866-231-8893 or email: [info@forno.ca](mailto:info@forno.ca)