

# Installation Instructions

## Kitchen and Bath Main Faucet Filtration System – GXK140TNN

### SAFETY PRECAUTIONS

- Check with your state and local public works department for plumbing and sanitation codes. You must follow these guidelines as you install the Kitchen and Bath Main Faucet Filtration System. Using a qualified installer is recommended.
- Be sure the water supply conforms with the Performance Data. If the water supply conditions are unknown, contact your municipal water company.

- ▲ WARNING** Do not use with water that is microbiologically unsafe or of unknown quality without adequate disinfection before or after the system. Systems certified for Cyst reduction may be used on disinfected waters that may contain filterable Cysts.
- It is highly recommended that a water shut-off valve be placed directly upstream of your Kitchen and Bath Main Faucet Filtration System.

### PARTS INCLUDED

- Filter Cartridge
- Filter Head/Bracket
- 6 Feet of 3/8" Tubing
- 3/8" x 1/2" Faucet Adapter
- 3/8" Compression Hex Nut
- 3/8" Ferrule
- 3/8" Tube Insert
- Mounting Screws
- 1/2" Compression to 3/8" Adapter
- 7/16" Compression to 3/8" Adapter

Optional accessories are available (Visa, MasterCard or Discover cards accepted) by visiting our Website at [ge.com](http://ge.com) or from Parts and Accessories, call 800.952.5039 (US)

### TOOLS YOU WILL NEED

Phillips-Head Screwdriver



Utility Knife



Adjustable Wrench



Drill with 1/8" Drill Bit

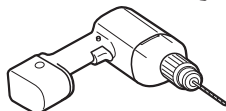

### PROPER INSTALLATION

This Kitchen and Bath Main Faucet Filtration System must be properly installed and located in accordance with the Installation Instructions before it is used.

- **Check with your local public works department for plumbing codes. You must follow their guides as you install the Kitchen and Bath Main Faucet Filtration System.**
- **Use the Kitchen and Bath Main Faucet Filtration System on a potable, safe-to-drink, home COLD water supply only. The filter cartridge will not purify water or make unsafe water safe to drink. DO NOT use on HOT water (100°F max).**
- **Protect the Kitchen and Bath Main Faucet Filtration System and piping from freezing. Water freezing in the system will damage it.**
- **The pressure of the water supply to the Kitchen and Bath Main Faucet Filtration System must be between the minimum of 20 PSI and the maximum of 100 PSI**
- **Your Kitchen and Bath Main Faucet Filtration System will withstand up to 100 psi water pressure. If your house water supply pressure is higher than 100 psi during the day (it may reach higher levels at night), install a pressure reducing valve before the system is installed.**
- **Do not install on HOT WATER.** The temperature of the water supply to the Kitchen and Bath Main Faucet Filtration System must be between the minimum of 34°F and the maximum of 100°F. See the Performance Data section.
- **Do not** install the Kitchen and Bath Main Faucet Filtration System using copper solder fittings. The heat from the soldering process will damage the unit.

**▲ WARNING** Discard all unused parts and packaging material after installation. Small parts remaining after installation could be a choke hazard.

- **Do not** install filter in an outside location or anywhere it will be exposed to sunlight.



Certified by IAPMO R&T to NSF/ANSI 42, 53, 401, and CSA B483.1, for the reduction claims specified [iapmo.org](http://iapmo.org); and to NSF/ANSI 372 for Low Lead content.

# Installation Instructions

## CARTRIDGE SPECIFICATIONS

Performance Data – Filtration System GXK140TNN Using Filter FQK1R

Rated/certified capacity = 1,500 gallons

Performance data sheet is available at [gewaterfilters.com](http://gewaterfilters.com)

## STEP-BY-STEP INSTALLATION INSTRUCTIONS

### Installation Overview

**NOTE:** Be sure to allow a minimum space of 1½”–2” under the system for removing the filter cartridge.

If you have copper tubing with 3/8” compression fittings, you’ll need to follow Step 3 Option B (Optional Installation).

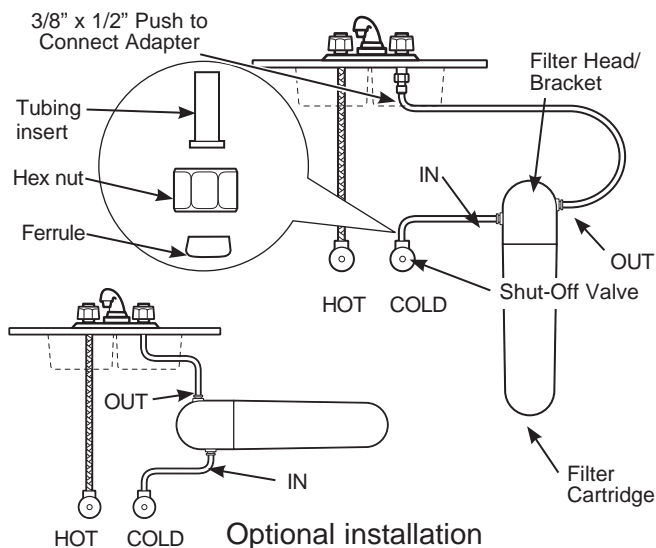

## FILTER CARTRIDGE REPLACEMENT

### Replacement Filter Canister

FQK1R—Replacement filter canister

For replacement parts, call toll-free 800.952.5039 (US)

### TO REMOVE FILTER:

- Turn filter 1/4 turn to the left. The top surface of the filter will move away from the bottom of the head. Pull the filter down to remove.

## FILTER CARTRIDGE REPLACEMENT (cont.)

### TO REPLACE FILTER:

- A** Push filter into the filter head/bracket. Turn filter 1/4 turn to the right until it stops. The top surface of the filter will be flush with the bottom of the filter head/bracket when fully installed. **NOTE:** When correctly installed, the label will face out.
- B** Turn on the cold water faucet to flush the filter for 5 minutes to remove air.
- C** Change the batteries in the timer.

**NOTE:** Remove the water in the line to minimize the water released during filter cartridge replacement. Turn off the cold water supply valve and turn on the faucet for 5 seconds.

## INSTALLING THE SYSTEM

### 1 SELECT A LOCATION

- A** Select a location for the system that is:
  - Protected from freezing.
  - Not exposed to direct sunlight.
- B** Select and mark a location under the sink that allows access for a filter cartridge change. See Section 4.

The system can be mounted vertically or horizontally. **DO NOT MOUNT THE SYSTEM UPSIDE DOWN.**

### 2 DISCONNECT COLD WATER SUPPLY

- A** Remove items from under the sink. Place a bucket and some towels under the sink to collect any water that may run out when disconnecting the water supply lines.
- B** Turn off the cold water supply valve and remove the existing water supply tubing and fittings.

**NOTE:** For copper tubing, leave the 3/8” compression fitting on the faucet stem. Go to Step 3, Option B.

# Installation Instructions

## 3 INSTALL FAUCET ADAPTER

Install the 3/8" x 1/2" faucet adapter to the faucet threads.

DO NOT OVERTIGHTEN.

Option A – Typical Installation

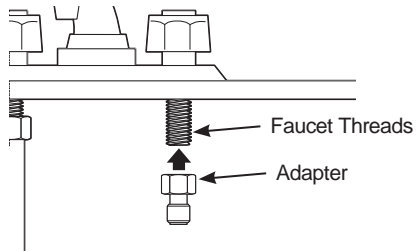

Option B – Optional Installation

If you have copper tubing with a compression adapter, you will NOT use the 1/2" faucet adapter.

Use a section of tubing, slide the compression hex nut and 3/8" ferrule (tapered end away from the compression nut) onto the tubing, and put in the tubing insert.

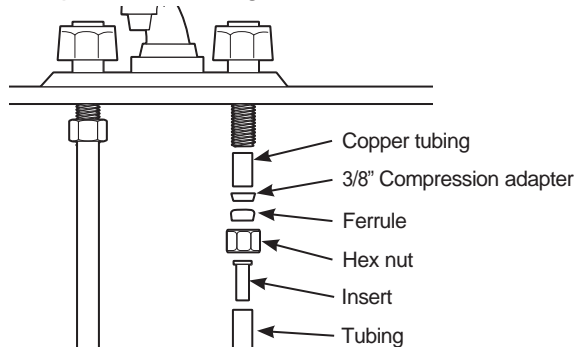

## 4 INSTALL THE HEAD/BRACKET

**A** Using the filter head/bracket as a guide, mark hole locations so that there is 1" between the center of each screw. Fasten the filter head/bracket to the wall with the Phillips screws provided with the unit.

**NOTE:** Pre-drill 1/8" holes for easier installation.

**B** Make sure to leave at least 2-1/2" from the bottom of the system to allow for easy replacement of the filter cartridge.

**C** Install screws only halfway so you can slip the bracket onto the wall during installation.

**NOTE:** There are three installation configurations. Select the appropriate screws for installation: For Cabinet Side Wall Installations, use 1" screws; For Drywall into Stud Installations, use 1-1/4" screws; For Drywall with No Stud Installations, use lag bolts.

**CAUTION** Be sure screw point does not protrude through the wall into adjacent cabinet.

**D** Tighten screws to secure the bracket.

## 5 CUTTING THE TUBING

**A** Determine the length of tubing necessary from the filter head/bracket to the faucet and from the water supply line to the filter head/bracket by holding the tubing in place to ensure it is the correct length.

**NOTE:** 6 feet of tubing is supplied. Cut the tubing into two sections according to your requirements.

**B** Cut tubing.

**NOTE:** Do not kink tubing.

**NOTE:** Check the end of the tubing to make sure there are no cuts, nicks, flat spots or sharp edges. If any of these are present, cut the end of the tube with a utility knife.

**C** Measure 3/4" from the end of the tubing provided and mark with a pencil.

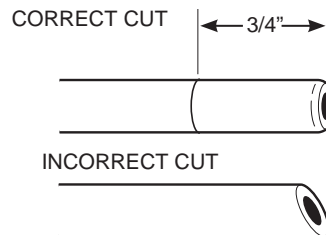

## 6 INSTALL TUBING

**A** Push the tubing firmly into the collet on the faucet adapter fitting until the pencil mark is pushed next to the collet. (If the tubing is removed, recut the end, measure, mark and reinsert.)

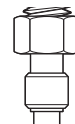

Tubing must be fully inserted to avoid leaks. To remove tubing: Depress and hold the white collet; pull the tubing out to remove.

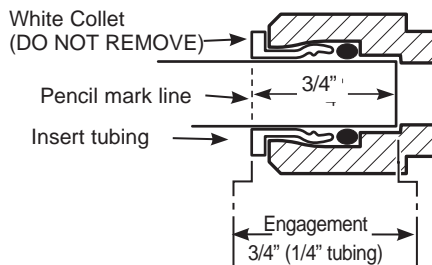

**B** Pull out slightly on the tubing to ensure a good seal.

**C** Press the other end of the tubing into the outlet side of the filter.

# Installation Instructions

## 7 INSTALL COMPRESSION FITTINGS

- A** Take the remaining section of tubing, slide the compression hex nut and 3/8" ferrule (tapered end away from the compression nut) onto the tubing, and put in the tube insert.

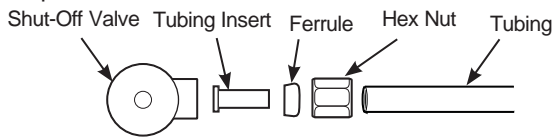

- B** Fasten the assembly onto the cold water supply valve. Do not overtighten.

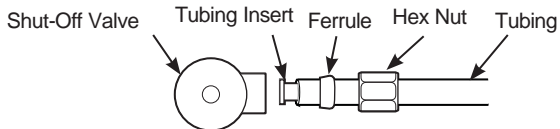

**NOTE:** Overtightening will cause the tubing to separate from the fitting.

**NOTE:** For shut-off valves with 1/2" or 7/16" compression fittings, please use appropriate adapters provided in the kit.

- C** Connect the other end to the inlet side as indicated by the arrow on the filter head/bracket.

## 8 INSTALL THE BATTERIES

- A** Insert coin or screwdriver in the slot between the timer cap and base.
- B** Gently pry open and separate the timer base from the cap. Install or change 2 new AAA 1.5 volt batteries. After having the batteries in place, line up the base and cap and snap them back together.
- C** After new batteries are installed or filter is changed, push and hold the timer blue reset button for approximately 5 seconds. Release the reset button after the light flashes 5 times. The light will flash again in 180 days to remind you that it is time to change the filter.
- D** Attach timer to remote location for easy viewing.

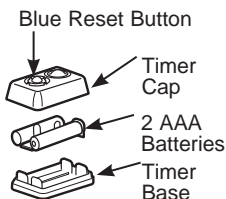

**NOTE:** Timer appearance may vary.

**NOTE:** Do not mix old and new batteries. Do not mix alkaline, standard (carbon-zinc) or rechargeable (ni-cad, ni-mh, etc.) batteries.

## 9 FINAL CHECK

- A** Insert the filter into the filter head/bracket. Turn the filter 1/4 turn to the right until it stops. The top surface of the filter will become flush with the bottom of the filter head/bracket when it is fully installed.
- B** Slowly turn on the water supply.
- C** Check the entire system for leaks. If there are leaks, refer back to the Cut the Tubing section to reinsert the tubing.
- D** If leaking from fittings, shut off water pressure and tighten or reseal fittings. If leaking from the filter, tighten the filter.
- E** After installation, let water run for approximately 10 minutes to flush the filter and to remove air.

**NOTE:** It is normal for there to be air in the system causing bubbles in the water.

## PARTS LIST

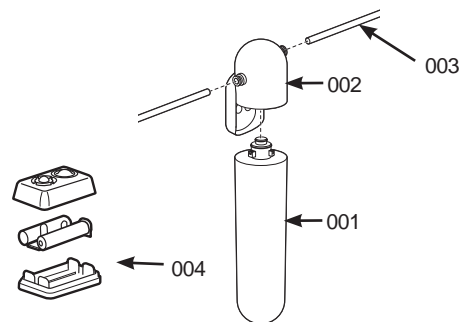

Ref. No.	Part No.	Part Description	
001	FQK1R	Replacement Filter Cartridge	1
002	WS19X10024	Filter Head/Bracket	1
003	GXULQ-KIT	Kit	1
004	GXULQ-TIMER	Timer and Batteries	1

To obtain replacement parts, call toll-free 800.952.5039 (US)

GE Appliances, a Haier company  
Louisville, KY 40225

### LIMITED ONE YEAR WARRANTY

- What does this warranty cover?
  - Any defect in materials or workmanship in the manufactured product.
- What does this warranty not cover?
  - Filter cartridge and batteries after 30 days from date of purchase.
  - Service trips to your home to teach you how to use the product.
  - Improper installation, delivery or maintenance.
  - Failure of the product if it is abused, misused, altered, used commercially or used for other than the intended purpose.
  - Use of this product where water is microbiologically unsafe or of unknown quality, without adequate disinfection before or after the system. Systems certified for cyst reduction may be used on disinfected water that may contain filterable cysts.
  - Damage to the product caused by accident, fire, floods or acts of God.
  - Incidental or consequential damage caused by possible defects with this appliance, its installation or repair.
- For how long after the original purchase?
  - One (1) year.

- How do I make a warranty claim?
  - Return to the retailer from which it was purchased, along with a copy of the "Proof of Purchase." A new or reconditioned unit will be provided. This warranty excludes the cost of shipping the product to your home.

**EXCLUSION OF IMPLIED WARRANTIES—Your sole and exclusive remedy is product exchange as provided in this Limited Warranty. Any implied warranties, including the implied warranties of merchantability or fitness for a particular purpose, are limited to one year or the shortest period allowed by law.**

This warranty is extended to the original purchaser and any succeeding owner for products purchased for home or office use within the USA. In Alaska, the warranty excludes the cost of shipping or service to your home or office. Some states do not allow the exclusion or limitation of incidental or consequential damages. This warranty gives you specific legal rights, and you may also have other rights, which vary from state to state. To know what your legal rights are, consult your local or state consumer affairs office or your state's Attorney General. Contact us at [geappliances.com](http://geappliances.com), or call toll-free at 800.952.5039 in the U.S., or 866.777.7627 in Canada.