

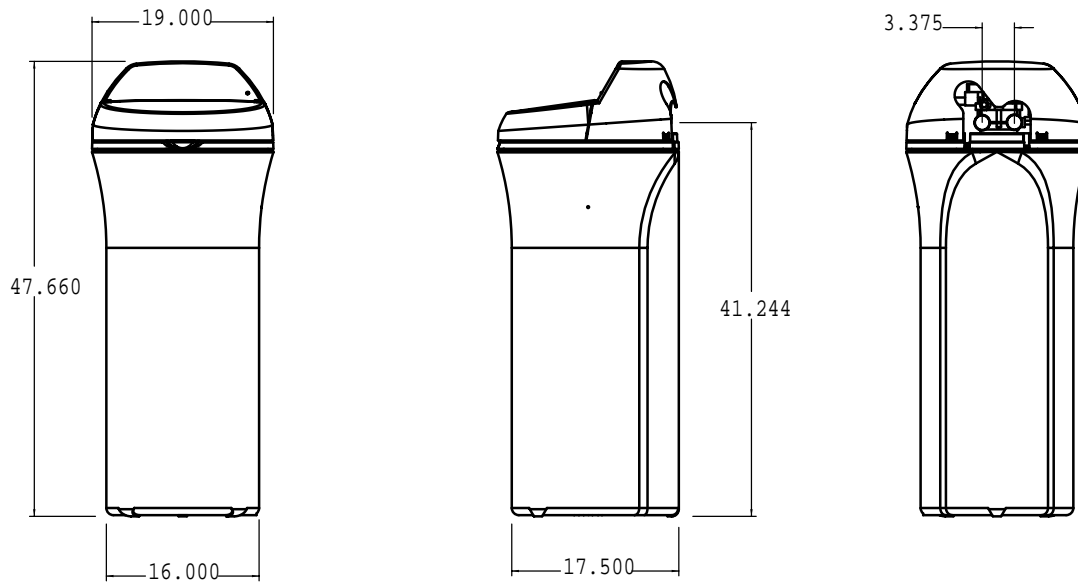

GE Appliances

GXSF27E – GE SmartWater™ Water Softening System



Salt Capacity – 200 lbs.

Important: All units must be installed according to local codes.

Note: Before installing, consult installation instructions packed with product for current dimensional data.



GNSH45E, GXSH39E and GXSF27E conform to ANSI/NSF 44 for specifically claimed performance.

Specification Created 9/02

For answers to your Monogram®, GE Profile™ or GE appliance questions, visit our website at GEAppliances.com or call GE Answer Center® service, 800.626.2000.



GE Appliances

GXSF27E – GE SmartWater™ Water Softening System

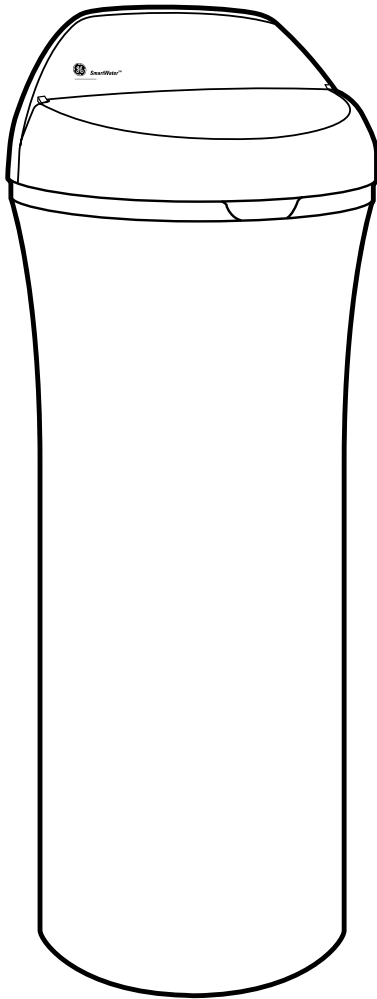

Features and Benefits

- SmartSoft™ Technology Monitors Water Usage and Anticipates Future Demands to Keep You in Soft Water
- 27,100 Grain Capacity
- Efficiency (5060 gpg)
- Maximum Hardness Removal (95 gpg)
- Maximum Iron Reduction (4 ppm)
- Salt Capacity (200 lbs.)
- Demand Initiated Regeneration – Only Regenerates When it Needs to
- Uses up to 60% less salt than conventional softeners.
- Low wattage transformer uses up to 50% less energy*
- Integrated head and cover for added electronic protection
- By-pass valve for added flexibility
- All parts needed for easy installation

*Versus other 24v transformer powered softeners.