

JGB928TEK/KEK/BEK

GE Profile™ 30" Free-Standing Double Oven Range

Dimensions and Installation Information (in inches)

Note: Dimension from the wall to the front of the closed door handle is 29". Depth to front edge of cooktop 25-1/4".

Installation Information: Before installing, consult installation instructions packed with product for current dimensional data.

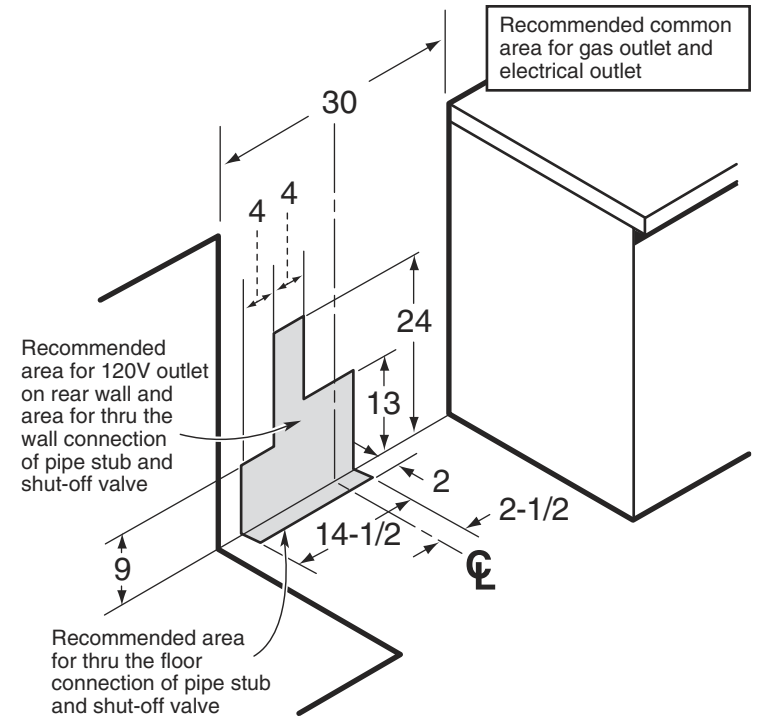
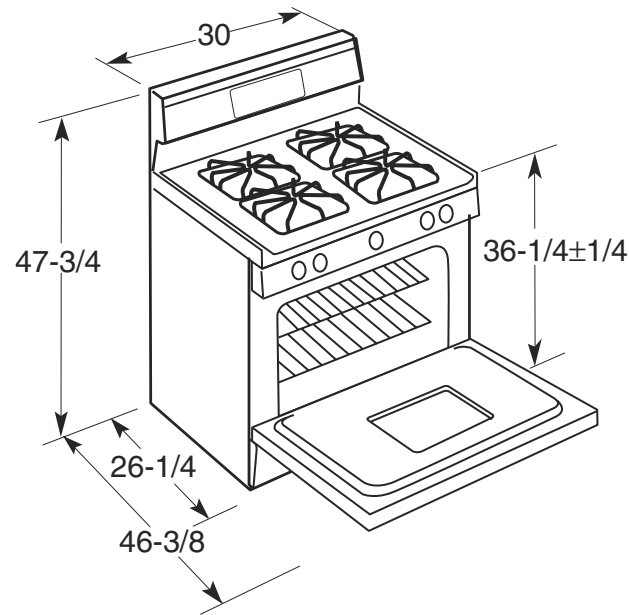

For answers to your Monogram®, GE Profile™ or GE® appliance questions, visit our website at ge.com or call GE Answer Center® service, 800.626.2000.



All GE ranges are equipped with an Anti-Tip device. The installation of this device is an important, required step in the installation of the range.



JGB928TEK/KEK/BEK

GE Profile™ 30" Free-Standing Double Oven Range

Features and Benefits

- Gas convection oven - Circulates air throughout the oven cavity ensuring better baking and roasting results
- Self clean oven - Conveniently cleans the oven cavity without need of scrubbing
- Extra-large oven capacity - Provides a large oven interior ideal for cooking more items at once
- Gas On Glass Cooktop - Features a flat one-piece ceramic glass surface that is sleek and easy-to-clean
- Lower Oven - Offers an additional 1.0 cu. ft. of capacity for convenient baking from 150 degrees to 450 degrees
- QuickSet VI glass touch oven controls - A smooth glass design that is easy-to-operate and easy-to-clean
- Power Boil™ Burner - Delivers 15,000 BTUs of forceful heat for rapid boiling
- Precise simmer burner - Offers the low setting of 600 BTUs, ensuring more temperature control for simmering
- Sealed cooktop burners - Eliminates the space between the burners and the cooktop to help contain spills and boil over liquids, ensuring easy cleanup
- TrueTemp™ system - Delivers even heat distribution and maximum oven control
- Big ClearView™ window - An extra large clear window makes monitoring the progress of the food easy
- Model JGB928TEKWW - True white
- Model JGB928KEKCC - True bisque
- Model JGB928BEKBB - Black on black

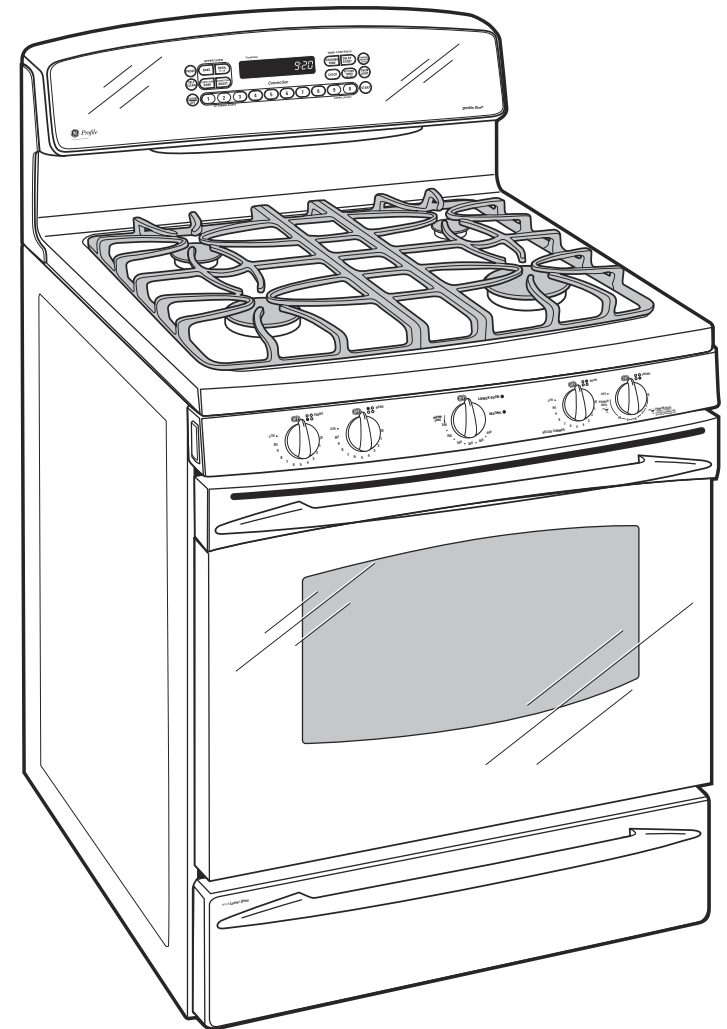

imagination at work