

L.P. CONVERSION INSTRUCTIONS

⚠ WARNING:

This conversion must be performed by a qualified installer or gas supplier in accordance with the manufacturer's instructions and all codes and requirements of the authority having jurisdiction. Failure to follow ALL instructions could result in serious injury or property damage. The qualified agency performing this work assumes responsibility for the conversion.

The pressure regulator and the burner orifices are set for natural gas. To use Liquid Propane Gas, the regulator, burner orifices and thermostat pins must be converted. The L.P. orifices for the cooktop burners and pins for the thermostat are shipped in a paper envelope on the back of the range.

⚠ WARNING:

Do not operate the cooktop or oven burners of this range when using L.P. (bottled) gas before converting the pressure regulator and burner orifices for L.P. gas use. Failure to do so could cause high flames and toxic fumes which can result in serious injury.

To adjust your range for use with L.P. gas, follow these instructions:

Shut off the gas supply to the range by closing the manual shut-off valve.

CONVERTING THE PRESSURE REGULATOR

- Raise the cooktop and locate the pressure regulator.
- Follow the direction in 1A or 1B depending on your regulator type.

NOTICE:

If you are using L.P. (bottled) gas, all adjustments described in the following steps must be made before you make any burner adjustments.

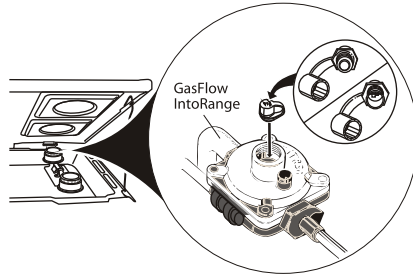

Regulator pictured may be different from your model.

1A-IF THIS IS YOUR REGULATOR

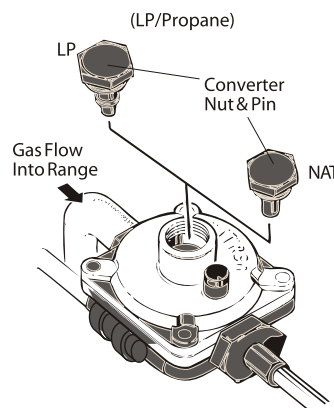

- Use an adjustable wrench to remove the hex-nut from the pressure regulator.
- Apply sideward finger pressure to remove the plastic pin from the nut.
Note: To remove the pin, place the nut on a flat surface and press the pin sideways with your fingers.

- Rotate the pin 180 degrees and snap the pin back into the nut.

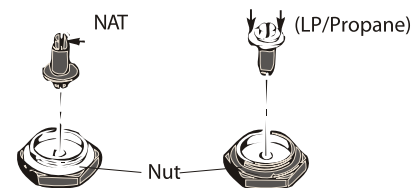

- Reinsert the assembly into the regulator and tighten the hex-nut. (Do not over tighten)

1B-IF THIS IS YOUR REGULATOR

- Use an adjustable wrench to unscrew the hex-nut cap from the pressure regulator.
- Apply pressure and turn counter clockwise to disassemble the plastic cap.

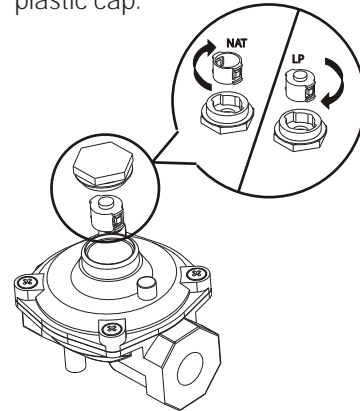

- Turn the cap over and hook it into the slots. The type of gas to be used should now be visible in the top of the cap.
- Screw back the hex-nut cap into the pressure regulator.

CONVERTING THE COOKTOP BURNERS

- Lift the burner assemblies straight up (set aside) to gain access to the surface burner orifice spuds.

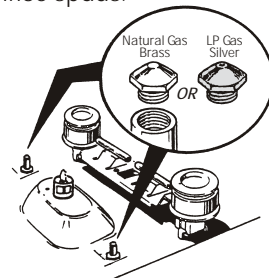

- Using a 5/16" (8 mm) nut driver or adjustable wrench, remove each of the four (4) spuds on the surface burner gas inlet tubes.
- Replace them with the correct gas spuds shipped in a paper envelope on the back of the range. To prevent leakage, make sure the spuds are securely screwed into the gas inlet tubes). (Natural gas spuds are "BRASS" and LP gas spuds are "SILVER")

NOTICE:

Save these orifices for future conversion back to natural gas.

- Return the spuds you removed from the inlet tubes to the paper envelope.
- Replace the burner assemblies.

CONVERTING THE OVEN BURNERS (on gas oven models only)

⚠ WARNING

The following adjustments must be made before turning on the gas to the oven burner. Failure to do so could result in serious injury due to high flames and toxic fumes.

OVEN BURNER ORIFICE

- Remove oven door, broil drawer, oven bottom, and burner. The oven burner orifice is located behind the drawer. On some models a metal shield must be removed.
- To convert to LP, replace oven orifice with the one supplied in kit with range.

NOTICE:

Save these orifices for future conversion back to natural gas.

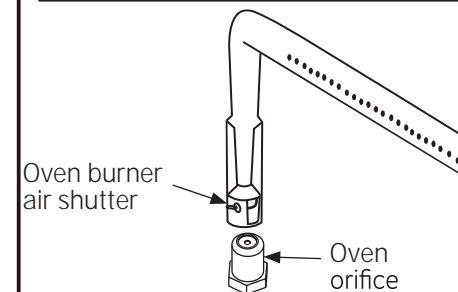

NOTICE:

This product cannot be converted to LP by adjusting the oven orifice. The orifice must be replaced for LP.

AIR SHUTTER SETTING FOR OVEN BURNER

- Turn on the gas.
- Turn on the electricity.
- Replace the oven bottom and reinstall the oven door.
- Turn on the oven burner.
- As you watch the flame with the oven oven door closed, check the following through the broil drawer opening.
 - If the flames are yellow, open the air shutter more. Use a screwdriver to loosen the air shutter screw.
 - If the flames continue to blow away or flutter from the burner after two minutes of operation, close the air shutter slightly, but not by more than 1/8".
- Retighten the air shutter screw.

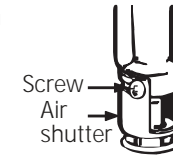

CHECKING THE FLAME SIZE

⚠ WARNING:

If you attempt to measure the inner cone of the flame, please use caution; burns could result.

- Checking the flame size: Check the inner cone of the flame. It should be approximately 1/2" to 3/4" long for the bake and broil burners.

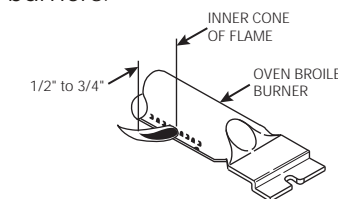

CHECKING THE FLAME QUALITY

The combustion quality of the burner flames need to be determined visually.

NOTE: If burner flames look like (A). Further air shutter adjustments required. Normal burner flames should look like (B) or (C), depending on the type of gas you use. With LP gas, some yellow tipping on the outer cones is normal.

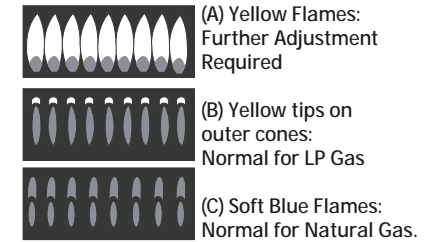

When all adjustments are made and the results are satisfactory:

- Replace the orifice fitting cover (in some models).
- Replace the oven bottom.

IN SOME CASES:

- With L.P. gas, some yellow tipping on the outer cone is normal.
- Foreign particles in the gas line may cause an orange flame at first, but this will soon disappear.

SPECIAL NOTE:

To convert the oven back to natural gas, reverse the instructions given in making L.P. Adjustments.

REPLACE OVEN PARTS

Replace the oven bottom, oven racks, oven door and broil drawer.

NOTICE:

Once the conversion is complete and checked ok, fill out the L.P. Sticker and include your name, organization and date conversion was made. Apply the sticker to the range near the regulator to alert others in the future that this appliance has been converted to L.P. If converting back to natural gas from L.P., please remove the sticker so others know the appliance is set to use natural gas.

**ADDITIONAL
INFORMATION**

BURNER OUTPUT RATINGS: BTU/HR		
LP (Propane) Gas, 10" W.C.P.		
BURNER	BTU RATE	ORIFICE SIZE
RF	8,000	#66 (.0330 Dia.)
LF	8,000	#66 (.0330 Dia.)
LR	8,000	#66 (.0330 Dia.)
RR	8,000	#66 (.0330 Dia.)
BAKE	16,000	0.048"

LP GAS
Spud is Silver

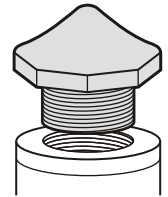

NATURAL GAS
Spud is Brass

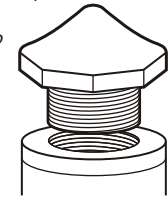

OR

BURNER OUTPUT RATINGS: BTU/HR		
NG (Natural) Gas, 4" W.C.P.		
BURNER	BTU RATE	COLOR
RF	9,100	#53 (.0590 Dia.)
LF	9,100	#53 (.0590 Dia.)
LR	9,100	#53 (.0590 Dia.)
RR	9,100	#53 (.0590 Dia.)
BAKE	18,000	0.080" (2.03)

TOOLS REQUIRED:

Adjustable wrench

½" open-end wrench

Phillips head screwdriver

Nut drivers: 5/16", 1/4" or 8mm

**L.P. CONVERSION
INSTRUCTIONS**
JGBS10, RGB508, RGB525

Pub. No. 31-10927-2
04-14 GE