



# 5.1 cu. ft. Dual Fuel Commercial-Style Range

KDRS463V



Stainless Steel  
KDRS463VSS

## Capacity

Oven 5.1 cu. ft.

## General Features & Properties

20K BTU Ultra Power™ Dual-Flame Burner

5K BTU Simmer/Melt Burner - Reduces to 500 BTUs

EasyConvect™ Conversion System

Convect Bake, Roast, and Broil

5.1 cu. ft. Total Capacity

Star-K Certified

## Electrical Details

Amps 40 or 50

Volts 120/240

## Certifications

ADA Compliant Yes

Star-K Certified/Kosher Yes

## Technical Details

Fuel Type Dual Fuel

Range Type Slide-In

Oven Cooking System Convection

Number of Oven Racks 3

Cleaning Type Self-Cleaning

Number of Burners 4

Burner Type Dual Flame & Sealed Burners

Burner Size/Power  
(1) 20000 BTU  
(2) 15,000 BTU  
(1) 5000 BTU

## Dimensions

Product Dimensions (H x W x D) 35-3/4" x 36" x 29-9/16"

Depth with Door Open 90° 46-1/8"

## Reference Material

[Dimension Guide](#)

[Install Guide](#)

[Use & Care Guide](#)

[Warranty](#)

## Key Features & Benefits

### Dual Fuel Range

Satisfies the culinary needs of the most demanding cooks by combining the precise control of a gas cooking surface with an electric oven.

### Even-Heat™ True Convection Oven

Provides consistent heating and even cooking on all racks with a unique bow-tie shaped design and convection fan that helps ensure no burnt edges or undercooked centers.

### Even-Heat™ Chrome Electric Griddle

Provides exceptional cooking performance and features an easy-to-clean surface.

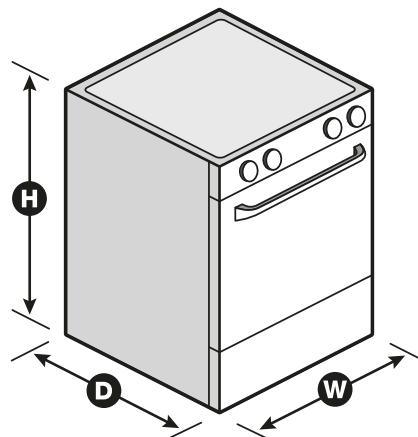

NOTE: Dimensions are for planning purposes only. For complete details, see Installation Instructions packed with product. Specifications subject to change without notice.

®/™ © 2020. All rights reserved. Printed in the U.S.A. D200052XXB. KDRS463VSPECSHEETV01.