

Microwave Oven

User manual

MC12DB8700**



SAMSUNG

Contents

Important safety instructions	3
What You Need To Know About Safety Instructions	3
Precautions To Avoid Possible Exposure To Excessive Microwave Energy	3
Important Safety Symbols And Precautions	4
Grounding Instructions	5
Use Of Extension Cords	5
Critical Installation Warnings	5
Installation Cautions	6
Critical Usage Warnings	6
Usage Cautions	7
Critical Cleaning Instructions	8
Installing Your Microwave Oven	8
Cleaning The Turntable And Roller Rings	9
Storing And Repairing Your Microwave Oven	9
California Proposition 65 Warning	10
Installation	10
What's included	10
Accessories	11
Turntable	11
Maintenance	12
Cleaning	12
Replacement (repair)	12
Care during an extended period of disuse	12
Before you start	13
Set Date & Time	13
Door Auto Lock	13
To open the door	13
Control Lock	14
About microwave energy	14
Cookware for microwave mode	14

Operations	15
Control panel	15
System Settings	16
Smart control	17
Voice control	17
Amazon Alexa & Google Assistant	18
Manual mode	19
Auto mode	23
Special functions	24
Cooking Smart	25
Auto Mode	25
Manual cooking	28
Quick & Easy	35
Troubleshooting	36
Checkpoints	36
Information codes	39
Technical specifications	39
Warranty	40

Important safety instructions

Congratulations on your new Samsung microwave oven. This manual contains important information on the installation, use and care of your appliance. Please take time to read this manual to take full advantage of your microwave oven's many benefits and features.

WHAT YOU NEED TO KNOW ABOUT SAFETY INSTRUCTIONS

Warnings and Important Safety Instructions in this manual do not cover all possible conditions and situations that may occur. It is your responsibility to use common sense, caution, and care when installing, maintaining, and operating your microwave oven.

PRECAUTIONS TO AVOID POSSIBLE EXPOSURE TO EXCESSIVE MICROWAVE ENERGY

- A. Do not attempt to operate this oven with the door open since open-door operation can result in harmful exposure to microwave energy. It is important not to defeat or tamper with the safety interlocks.
- B. Do not place any object between the oven front face and the door or allow soil or cleaner residue to accumulate on the sealing surface.
- C. Do not operate the oven if it is damaged. It is particularly important that the oven door close properly and that there is no damage to the:
 - 1) Door (bent),
 - 2) Hinges and latches, (broken or loosened),
 - 3) Door seals and sealing surface.
- D. The oven should not be adjusted or repaired by anyone except properly qualified service personnel.

When using any electrical appliance, basic safety precautions should be followed, including the following:

WARNING

To reduce risk of burns, electric shock, fire, personal injury or exposure to excessive microwave energy:

1. Read all safety instructions before using the appliance.
2. Read and follow the specific "Grounding Instructions" on page 5 of this manual.
3. "Precautions To Avoid Possible Exposure To Excessive Microwave Energy" on page 3.
4. This appliance must be grounded. Connect only to properly grounded outlets. See Important "Grounding Instructions" on page 5 of this manual.
5. Install or locate this appliance only in accordance with the provided installation instructions.
6. Some products such as whole eggs and sealed containers (for example, closed glass jars) can explode if heated rapidly. Never heat them in a microwave oven.
7. Do not use this appliance for other purposes than cooking. Drying of clothing and heating of warming pads, slippers, sponges, damp cloth and similar may lead to risk of injury, ignition or fire. Use this appliance only for its intended use as described in the manual. Do not put corrosive chemicals or vapors in or on this appliance. This type of oven is specifically designed to heat, cook, or dry food. It is not designed for industrial or laboratory use.
8. **HOT CONTENTS CAN CAUSE SEVERE BURNS. DO NOT ALLOW CHILDREN TO USE THE MICROWAVE.**
9. Do not operate this appliance if it has a damaged cord or plug, if it is not working properly, or if it has been damaged or dropped.
10. This appliance should be repaired or serviced only by qualified service personnel. Contact the nearest authorized service facility for examination, repair, or adjustment.
11. Do not cover or block any openings on the appliance.
12. Do not tamper with or make any adjustments or repairs to the door.
13. Do not store this appliance outdoors. Do not use this product near water, for example, near a kitchen sink, in a wet basement, near a swimming pool, or similar locations.
14. Do not immerse the cord or plug in water.
15. Keep the cord away from heated surfaces. (including the back of the oven).

SAVE THESE INSTRUCTIONS

Important safety instructions

16. Do not let the cord hang over edge of table or counter.
17. When cleaning surfaces of the door and oven that come together when the door closes, use only mild, nonabrasive soaps, or detergents applied with a sponge or soft cloth. Unplug the plug before cleaning.
18. To reduce the risk of fire in the oven cavity:
 - A. Do not overcook food. Carefully attend appliance when paper, plastic, or other combustible materials are placed inside the oven to facilitate cooking.
 - B. Remove wire twist-ties from paper or plastic bags before placing the bags in the oven.
 - C. If materials inside the oven ignite, keep the oven door closed, turn the oven off, and disconnect the power cord, or shut off the power at the fuse or circuit breaker panel. If the door is opened, the fire may spread.
 - D. Do not use the cavity for storage purposes. Do not leave paper products, cooking utensils, or food in the cavity when not in use.
19. Liquids, such as water, milk, coffee, or tea can be overheated beyond the boiling point without appearing to be boiling. Visible bubbling or boiling when the container is removed from the microwave oven is not always present. **THIS COULD RESULT IN VERY HOT LIQUIDS SUDDENLY BOILING OVER WHEN THE CONTAINER IS DISTURBED OR A SPOON OR OTHER UTENSIL IS INSERTED INTO THE LIQUID.** To reduce the risk of injury:
 - A. Do not overheat liquid.
 - B. Stir liquid both before and halfway through heating it.
 - C. Do not use straight-sided containers with narrow necks.
 - D. After heating, allow the container to stand in the microwave oven for a short time before removing the container.
 - E. Use extreme care when inserting a spoon or other utensil into the container.
20. Oversized foods or oversized metal utensils should not be inserted in microwave / toaster oven as they may create a fire or electric shock.
21. Do not clean with metal scouring pads. Piece can burn off the pad and touch electrical parts involving a risk of electric shock.
22. Do not use paper products when appliance is operated in the toaster mode.
23. Do not store any materials, other than manufacturer's recommended accessories, in this oven when not in use.
24. Do not cover racks or any other part of the oven with metal foil. This will cause overheating of the oven.

SAVE THESE INSTRUCTIONS

IMPORTANT SAFETY SYMBOLS AND PRECAUTIONS

What the icons and signs in this user manual mean:

WARNING

Hazards or unsafe practices that may result in **severe personal injury or death**.

CAUTION

Hazards or unsafe practices that may result in **minor personal injury or property damage**.

CAUTION

To reduce the risk of fire, explosion, electric shock, or personal injury when using your microwave oven, follow these basic safety precautions.

These warning signs are here to prevent injury to you and others. Please follow them explicitly. After reading this section, keep it in a safe place for future reference.

CAUTION

Push button type model only

- Pre-caution for safe use to avoid possible exposure to excessive micro oven energy :
Do not attempt to pull any part of the door by hand to open the door. Open the door only utilizing the push button located at front-right-bottom side.

GROUNDING INSTRUCTIONS

This appliance must be grounded. In the event of an electrical short circuit, grounding reduces the risk of electric shock by providing an escape wire for the electrical current. This appliance is equipped with a cord that includes a grounding wire and a grounding plug. The plug must be plugged into an outlet that is properly installed and grounded.

WARNING

Improper use of the grounding plug can result in a risk of electric shock.

- Plug into a grounded 3 prong outlet. Do not remove the third (grounding) prong.
Do not use an adaptor or otherwise defeat the grounding plug.
- Consult a qualified electrician or service person if you do not understand the grounding instructions or if you are not sure if the appliance is properly grounded.
- We do not recommend using an extension cord with this appliance. If the power-supply cord is too short, have a qualified electrician or serviceman install an outlet near the appliance. However, if it is necessary to use an extension cord, read and follow the "Use of Extension Cords" section below.

USE OF EXTENSION CORDS

A short power-supply cord is provided to reduce the risk of your becoming entangled in or tripping over a longer cord. Longer cord sets or extension cords are available and you can use them if you exercise care. If you use a long cord or extension cord:

1. The marked electrical rating of the cord set or extension cord should be at least as great as the electrical rating of the appliance.
2. The extension cord must be a grounding-type 3-wire cord and it must be plugged into a 3-slot outlet.
3. The longer cord should be arranged so that it will not drape over the counter top or tabletop where it can be pulled on by children or tripped over accidentally. If you use an extension cord, the interior light may flicker and the speed of the blower may vary when the microwave oven is on. Cooking times may be longer too.

CRITICAL INSTALLATION WARNINGS

The installation of this appliance must be performed by a qualified technician or service company.

- Failing to have a qualified technician install the oven may result in electric shock, fire, an explosion, problems with the product, or injury.

Unpack the oven, remove all packaging material and examine the oven for any damage such as dents on the interior or exterior of the oven, broken door latches, cracks in the door, or a door that is not lined up correctly. If there is any damage, do not operate the oven and notify your dealer immediately.

Make sure to install your oven in a location with adequate space.

Remove all foreign substances such as dust or water from the power plug terminals and contact points using a dry cloth on a regular basis.

- Unplug the power plug and clean it with a dry cloth.
- Failing to do so may result in electric shock or fire.

Plug the power cord into a properly grounded 3 pronged outlet. Your oven should be the only appliance connected to this circuit.

- Sharing a wall socket with other appliances, using a power strip, or extending the power cord may result in electric shock or fire.
- Do not use an electric transformer. It may result in electric shock or fire.
- Ensure that the voltage, frequency and current provided match the product's specifications. Failing to do so may result in electric shock or fire.

SAVE THESE INSTRUCTIONS

Important safety instructions

Keep all packaging materials out of the reach of children. Children may use them for play. Do not install this appliance in a humid, oily, or dusty location, or in a location exposed to direct sunlight or water (rain drops).

- This may result in electric shock or fire.

Plug the power plug into the wall socket firmly. Do not use a damaged power plug, damaged power cord, or loose wall socket.

- This may result in electric shock or fire.

Do not mount over a sink.

Do not pull or excessively bend the power cord.

Do not twist or tie the power cord.

Do not hook the power cord over a metal object, place a heavy object on the power cord, insert the power cord between objects, or push the power cord into the space behind the appliance.

- This may result in electric shock or fire.

Do not pull the power cord when you unplug the oven.

- Unplug the oven by pulling the plug only.
- Failing to do so may result in electric shock or fire.

When the power plug or power cord is damaged, contact your nearest service center for a replacement or repair.

INSTALLATION CAUTIONS

Position the oven so that the plug is easily accessible.

- Failing to do so may result in electric shock or fire due to electric leakage.

Unplug the oven when it is not being used for long periods of time or during a thunder/lightning storm.

- Failing to do so may result in electric shock or fire.

SAVE THESE INSTRUCTIONS

CRITICAL USAGE WARNINGS

If the microwave appliance is flooded, please contact your nearest service center. Failing to do so may result in electric shock or fire.

Read and follow the specific "Precautions to Avoid Possible Exposure to Excessive Microwave Energy", found in the beginning of this Safety Information Section.

If the microwave generates a strange noise, a burning smell or smoke, unplug it immediately and contact your nearest service center.

- Failing to do so may result in electric shock or fire.

In the event of a gas leak (propane gas, LP gas, etc.), ventilate the room immediately. Do not touch the microwave, power cord, or plug.

- Do not use a ventilating fan.
- A spark may result in an explosion or fire.

Take care that the door or any of the other parts do not come into contact with your body while cooking or just after cooking.

- Failing to do so may result in burns.

In the event of a grease fire on the surface units below the oven, smother the flaming pan on the surface unit by covering the pan completely with a lid, a cookie sheet, or a flat tray.

Never leave surface units beneath your oven unattended at high heat settings.

Boil overs cause smoking and greasy spillovers that may ignite and spread if the vent fan is operating. To minimize automatic fan operation, use adequate sized cookware and use high heat on surface units only when necessary.

If materials inside the oven should ignite, keep the oven door closed, turn the oven off and disconnect the power cord, or shut off power at the fuse or circuit breaker panel. If the door is opened, the fire may spread.

- Always observe Safety Precautions when using your oven. Never try to repair the oven on your own. There is dangerous voltage inside. If the oven needs to be repaired, contact an authorized service center near you.

Do not attempt to repair, disassemble, or modify the appliance yourself.

- Because a high voltage current enters the product chassis during operation, opening the chassis can result in electric shock or fire.
- You may be exposed to electromagnetic waves.
- When the oven requires repair, contact your nearest service center.

If any foreign substance such as water enters the microwave, unplug it and contact your nearest service center.

- Failing to do so may result in electric shock or fire.

Do not touch the power plug with wet hands.

- This may result in electric shock.

Do not turn the appliance off by unplugging the power plug while the appliance is in operation.

- Plugging the power plug into the wall socket again may cause a spark and result in electric shock or fire.

Keep all packaging materials well out of the reach of children. Packaging materials can be dangerous to children.

- If a child places a bag over its head, the child can suffocate.

Do not let children or any person with reduced physical, sensory or mental capabilities use this appliance unsupervised. Make sure that the appliance is out of the reach of children.

- Failing to do so may result in electric shock, burns or injury.

Do not touch the inside of the appliance immediately after cooking. The inside of the appliance will be hot.

- The heat on the inside of the oven can cause burns.

Do not put aluminum foil (except as specifically directed in this manual), metal objects (such as containers, forks, etc.) or containers with golden or silver rims into the microwave.

- These objects can cause sparks or a fire.

Do not use or place flammable sprays or objects near the oven.

- Heat from the microwave can cause flammable sprays to explode or burn.
- Failing to do so may result in electric shock or injury.

Do not tamper with or make any adjustments or repairs to the door. Under no circumstances should you remove the outer cabinet.

Do not store or use the oven outdoors.

USAGE CAUTIONS

If the surface of the microwave is cracked, turn it off.

- Failing to do so may result in electric shock.

Dishes and containers can become hot. Handle with care.

Hot foods and steam can cause burns. Carefully remove container coverings, directing steam away from your hands and face.

Remove lids from baby food before heating. After heating baby food, stir well to distribute the heat evenly. Always test the temperature by tasting before feeding the baby. The glass jar or surface of the food may appear to be cooler than the food in the interior, which can be so hot that it will burn the infant's mouth.

Make sure all cookware used in the oven is suitable for microwaving.

Use microwavable cookware in strict compliance with such manufacturer's recommendations.

Do not stand on top of the microwave or place objects (such as laundry, oven covers, lighted candles, lighted cigarettes, dishes, chemicals, metal objects, etc.) on the appliance.

- Items, such as a cloth, may get caught in the door.
- This may result in electric shock, fire, problems with the product, or injury.

Do not operate the appliance with wet hands.

- This may result in electric shock.

Do not spray volatile material such as insecticide onto the surface of the appliance.

- As well as being harmful to humans, it may also result in electric shock, fire or problems with the product.

Do not place the appliance over a fragile object such as a sink or glass object.

- This may result in damage to the sink or glass object.

Do not put your face or body close to the appliance while cooking or when opening the door just after cooking.

- Take care that children do not come too close to the appliance.
- Failing to do so may result in children burning themselves.

Do not place food or heavy objects over the door when opening the door.

- The food or object may fall and this may result in burns or injury.

SAVE THESE INSTRUCTIONS

Important safety instructions

Do not abruptly cool the door, the inside of the appliance, or the dish by pouring water over it during or just after cooking.

- This may result in damage to the appliance. The steam or water spray may result in burns or injury.

Do not cook without the glass tray in place on the oven floor. Food will not cook properly without the tray.

Do not defrost frozen beverages in narrow-necked bottles. The containers can break.

Do not scratch the glass of the oven door with a sharp object.

- This may result in the glass being damaged or broken.

Do not store anything directly on top of the appliance when it is in operation.

Do not use sealed containers. Remove seals and lids before use. Sealed containers can explode due to buildup of pressure even after the oven has been turned off.

CRITICAL CLEANING INSTRUCTIONS

Do not clean the appliance by spraying water directly onto it.

Do not use benzene, thinner, or alcohol to clean the appliance.

- This may result in discoloration, deformation, damage, electric shock, or fire.

Before cleaning or performing maintenance, unplug the appliance from the wall socket and remove food waste from the door and cooking compartment.

- Failing to do so may result in electric shock or fire.

Take care not to hurt yourself when cleaning the appliance. (external/internal)

- You may hurt yourself on the sharp edges of the appliance.

Do not clean the appliance with a steam cleaner.

- This may result in corrosion.

Keep the inside of the oven clean. Food particles or spattered oils stuck to the oven walls or floor can cause paint damage and reduce the efficiency of the oven.

SAVE THESE INSTRUCTIONS

INSTALLING YOUR MICROWAVE OVEN

Place the oven on a flat level surface 33.5 inches (85 cm) above the floor. The surface should be strong enough to safely bear the weight of the oven.

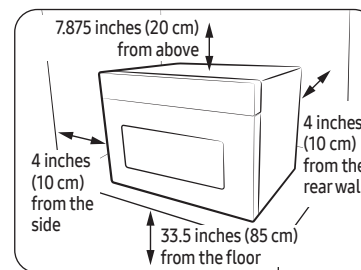

Trim kit(MA-TK3080CT/AA) is required in order to be installed in a built-in application.

1. When you install your oven, make sure there is adequate ventilation for your oven by leaving at least 4 inches (10 cm) of space behind and, on the sides of the oven and 7.875 inches (20 cm) of space above.
 2. Remove all packing materials inside the oven.
 3. Install the roller ring and turntable. Check that the turntable rotates freely. (Turntable type model only)
 4. This microwave oven has to be positioned so that plug is accessible.
 5. This microwave oven has to be positioned so that plug is accessible.
 - If the supply cord is damaged, it must be replaced by the manufacturer, a service agent, or a similarly qualified person in order to avoid a hazard. For your personal safety, plug the cable into a proper AC earthed socket.
 - Do not install the microwave oven in hot or damp surroundings like next to a traditional oven or radiator. The power supply specifications of the oven must be respected and any extension cable used must be of the same standard as the power cable supplied with the oven. Wipe the interior and the door seal with a damp cloth before using your microwave oven for the first time.
- NOTE**
- A trim kit is available for select models (MC12DB8700**). The trim kit allows you to install this microwave in a cabinet or any other built-in application. For complete installation instructions, see the trim kit installation manual. To purchase trim kit visit our online store.
 - When using the trim kit, make sure to turn off the **Door Auto Lock** function before using it. Please refer to the **Door Auto Lock** guide on page 13.

CLEANING THE TURNTABLE AND ROLLER RINGS

Clean the roller rings periodically and wash the turntable as required. You can wash the turntable safely in your dishwasher.

STORING AND REPAIRING YOUR MICROWAVE OVEN

If you need to store your microwave oven for a short or extended period of time, choose a dust-free, dry location. Dust and dampness may adversely affect the microwave parts.



- Do not repair, replace or service any part of your microwave oven yourself. Allow only a qualified service technician to perform repairs. If the oven is faulty and needs servicing, or you are in doubt about its condition, unplug the oven from the power outlet and contact your nearest service center.
- Do not use the oven if it is damaged, in particular, if the door or door seals are damaged. Door damage includes a broken hinge, a worn out seal, or distorted/bent casing.
- Do not remove the oven from its casing.
- This microwave oven is for home use only and is not intended for commercial use.

1. FCC Notice

FCC STATEMENT:

This equipment generates and uses ISM frequency energy and if not installed and used properly, that is in strict accordance with the manufacturer's instructions, may cause interference to radio and television reception. It has been type tested and found to comply with limits for ISM Equipment pursuant to part 18 of FCC Rules, which are designed to part 18 of FCC Rules, which are designed to provide residential installation.

However, there is no guarantee that interference will not occur in a particular installation. If this equipment does cause interference to radio or television reception, which can be determined by turning the equipment off and on, the user is encouraged to try to correct the interference by one or more of the following:

- Reorient the receiving antenna of the radio or television.
- Relocate the Microwave Oven with respect to the receiver.
- Move the microwave oven away from the receiver.
- Plug the microwave oven into a different outlet so that the microwave oven and the receiver are on different branch codes.

The manufacturer is not responsible for any radio or TV interference caused by unauthorized modification to this microwave oven. It is the responsibility of the user to correct such interference.

This equipment has been tested and found to comply with the limits for a Class B digital device, pursuant to part 15 of the FCC Rules. These limits are designed to provide reasonable protection against harmful interference in a residential installation. This equipment generates, uses and can radiate radio frequency energy and, if not installed and used in accordance with the instructions, may cause harmful interference to radio communications. However, there is no guarantee that interference will not occur in a particular installation. If this equipment does cause harmful interference to radio or television reception, which can be determined by turning the equipment off and on, the user is encouraged to try to correct the interference by one or more of the following measures:

- Reorient or relocate the receiving antenna.
- Increase the separation between the equipment and receiver.
- Connect the equipment into an outlet on a circuit different from that to which the receiver is connected.
- Consult the dealer or an experienced radio/TV technician for help.

SAVE THESE INSTRUCTIONS

Important safety instructions

⚠ WARNING

Any changes or modifications to this unit not expressly approved by the party responsible for compliance could void the user's authority to operate the equipment.

FCC RF Exposure Requirements

This device complies with FCC RF radiation exposure limits set forth for an uncontrolled environment. The antenna(s) used for this transmitter must not be co-located or operating in conjunction with any other antenna or transmitter and must be installed to provide a separation distance of at least 20 cm from all persons.

2. IC Notice

This device contains licence-exempt transmitter(s)/receiver(s) that comply with Innovation, Science and Economic Development Canada's licence-exempt RSS(s). Operation is subject to the following two conditions:

1. This device may not cause interference.
2. This device must accept any interference, including interference that may cause undesired operation of the device.
 - CAN ICES (B)/NMB (B).

IC RADIATION EXPOSURE STATEMENT:

This equipment complies with IC RSS-102 radiation exposure limits set forth for an uncontrolled environment. This equipment should be installed and operated so there is at least 8 inches (20 cm) between the radiator and your body. This device and its antenna(s) must not be co-located or operated in conjunction with any other antenna or transmitter.

CALIFORNIA PROPOSITION 65 WARNING

⚠ WARNING

Cancer and Reproductive Harm - www.P65Warnings.ca.gov.

SAVE THESE INSTRUCTIONS

Installation

What's included

Make sure all parts and accessories listed on this page and the next page are included in the product package. If you have a problem with the oven or accessories, contact a local Samsung customer center or the retailer.

Oven at a glance

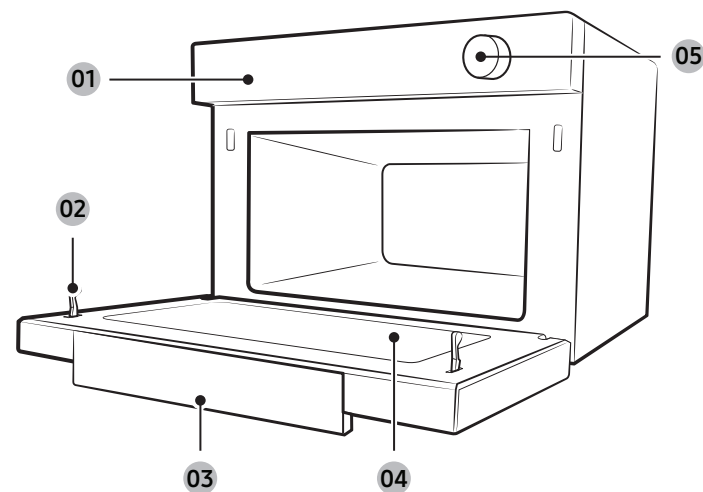

01 Control panel

02 Safety Door Lock

03 Door Handle

04 Door

05 Dial

Accessories

The oven comes with different accessories that help you prepare different types of food.



Roller ring

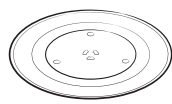

Turntable



Crusty plate

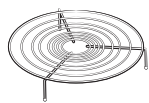

Low rack

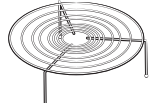

High rack

Roller ring	Put in the center of the base. It supports the turntable.
Turntable	Put on the roller ring with the center fitting the coupler. It serves as a cooking base.
Racks	Use one of these racks as appropriate to cook two dishes simultaneously. A smaller dish on the turntable, and the other on the selected rack. You can use these racks with Grill Convection or Combination Cooking. NOTE Do not use wire racks with Microwave mode.
Crusty plate	Put on the turntable. Use this to brown food, or to keep pastries or pizza crisp.

IMPORTANT

DO NOT operate the oven without the turntable on the roller ring.

NOTE

If you need an accessory, please contact the Samsung Call Center using the phone number listed on the last page of this manual or visit our online parts web site at www.samsungparts.com.

Turntable

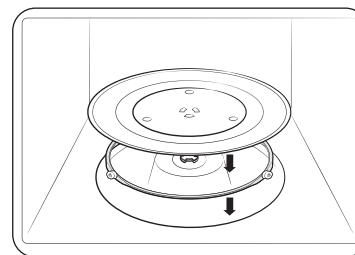

- Remove all packing materials inside the oven.
- Install the roller ring and turntable.
- Check that the turntable rotates freely.

Maintenance

Cleaning

Clean the oven regularly to prevent impurities from building up on or inside the oven. Also pay special attention to the door, door seal, and turntable and roller ring (applicable models only).

If the door won't open or close smoothly, first check if the door seals have built up impurities. Use a soft cloth in soapy water to clean both the inner and outer sides of the oven. Rinse and dry well.

To remove stubborn impurities from inside the oven

1. With an empty oven, put a cup of diluted lemon juice on the center of the turntable.
2. Heat the oven for 10 minutes at max power.
3. When the cycle is complete, wait until the oven cools down. Then, open the door and clean the cooking cavity.

CAUTION

- Keep the door and door seal clean and ensure the door opens and closes smoothly. Otherwise, the oven's lifecycle may be shortened.
- Take caution not to spill water into the oven vents.
- Do not use any abrasive or chemical substances for cleaning.
- After each use of the oven, use a mild detergent to clean the cooking cavity after waiting for the oven to cool down.

Replacement (repair)

WARNING

This oven has no user-removable parts inside. Do not try to replace or repair the oven yourself.

- If you encounter a problem with hinges, seal and/or the door, contact a qualified technician or a local Samsung service center for technical assistance.
- If you want to replace the light bulb, contact a local Samsung service center. Do not replace it yourself.
- If you encounter a problem with the outer housing of the oven, first unplug the power cord from the power source, and then contact a local Samsung service center.

Care during an extended period of disuse

If you don't use the oven for an extended period of time, unplug the power cord and move the oven to a dry, dust-free location. Dust and moisture that builds up inside the oven may affect the performance of the oven.

Before you start

There are two microwave components that you should know about before going directly to a recipe. Before or during any cooking mode, you can set/change the clock or the kitchen timer to your needs.

Set Date & Time

It is important to set the correct clock time to ensure correct automatic operations.

1. Use the Dial to find and select **Setting**.
2. Use the Dial to find and select **Date & Time**.
3. Use the Dial to select **Manual Mode**.

NOTE

This guide is for manual mode. If you connect your microwave to SmartThings, the date & time can be updated automatically.

4. Use the Dial to enter month, day, year, hour and minute.
5. For 12 hour display mode, use the Dial to set AM or PM.

Door Auto Lock

When **Door Auto Lock** function is on, the door will be locked automatically for safety reasons.

NOTE

- When oven is powered up at first, it will not lock until it operate in any mode.
- If nothing is operated for 30 minutes after cooking, door will be unlocked and can be opened without touching **Door Unlock** button.
- The door is not locked in standby mode other than cooking operation.

To turn **Door Auto Lock** function on or off.

1. Use the Dial to find **Door Auto Lock** at **Setting**.
2. Select on or off, then press the Dial.

To open the door

Touch **Door Unlock** to open the door.

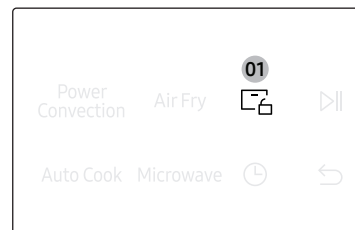

1. Touch **Door Unlock**.
2. Open the door.

NOTE

When the microwave oven stops while working due to a power outage or malfunction, force the door open through the following steps.

1. Before you force the door open, unplug your oven.
2. Find forced open hole located on the front.
3. Insert the following tool into the forced open hole and pull the door while pressing it.

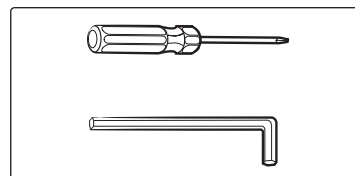

Required tool for service

Use the commercial tools less than 2 mm in diameter, longer than 100 mm.

NOTE

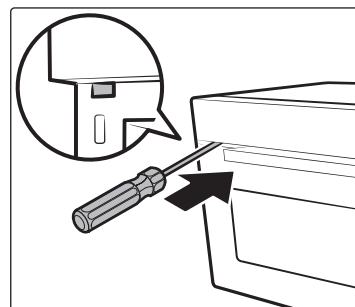

Tools for service is not included.



4. When error codes occurs for the **Door Unlock** function, the service must be received.

Before you start

Control Lock

To prevent accidents, **Control Lock** disables all controls except . To turn **Control Lock** function on, use Dial to find **Control Lock** at **Setting**. Hold down  button for 3 sec to turn **Control Lock** off.

About microwave energy

Microwaves are high-frequency electromagnetic waves. The oven uses its built-in magnetron to generate microwaves which cook or reheat food without deforming or discolouring the food.

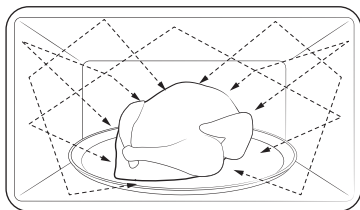

1. The microwaves generated by the magnetron are distributed uniformly by the whirling distribution system. This is why the food is cooked evenly.
2. The microwaves are absorbed into the food up to a depth of approximately 1 inch (2.5 cm). Then, the microwaves are dissipated inside the food as cooking continues.
3. The cooking time is affected by the following conditions of the food:
 - Quantity and density
 - Moisture content
 - Initial temperature (especially, when frozen)

NOTE

The cooked food keeps heat in its core after cooking is complete. This is why you must observe the standing times specified in this manual, which ensure that the food is cooked evenly down to the core.

Cookware for microwave mode

Cookware used for Microwave Mode must allow microwaves to pass through and penetrate food. Metals such as stainless steel, aluminum, and copper reflect microwaves. Therefore, do not use cookware made of metallic materials. Cookware marked Microwave safe is always safe for use. For additional information on appropriate cookware, refer to the following guide.

Requirements:

- Flat bottom and straight sides
- Tight-fitting lid
- Well-balanced pan with handles that weigh less than the main pan

Material	Microwave-safe	Description	
Aluminium foil	△	Use for a small serving size to protect against overcooking. Arcing can occur if the foil is near the oven wall or if using an excessive amount of foil.	
Crusty plate	○	Do not use for preheating for more than 8 minutes.	
Bone china or earthenware	○	Porcelain, pottery, glazed earthenware and bone china are usually microwave-safe, unless decorated with a metal trim.	
Disposable polyester cardboard dishes	○	Some frozen foods are packaged in these dishes.	
Fast-food packaging	Polystyrene cups or containers	○	Overheating may cause these to melt.
	Paper bags or newspaper	×	These may catch fire.
	Recycled paper or metal trims	×	These may cause arcing

Material		Microwave-safe	Description
Glassware	Oven-to-table ware	○	Microwave-safe unless decorated with metal trims.
	Fine glassware	○	Delicate glassware may break or crack if heated rapidly.
	Glass jars	○	Appropriate for warming only. Remove the lid before cooking.
Metal	Dishes	✗	These may cause arcing or fire.
	Freezer bag with twist-ties	✗	
Paper	Plates, cups, napkins, and kitchen paper	○	Use to cook for a short time. These absorb excess moisture.
	Recycled paper	✗	Causes arcing.
Plastic	Containers	○	Use thermoplastic containers only. Some plastics may warp or discolour at high temperatures.
	Cling film	○	Use to maintain moisture after cooking.
	Freezer bags	△	Use boilable or ovenproof bags only.
Wax or grease-proof paper		○	Use to maintain moisture and prevent spattering.

○ : Microwave safe

△ : Use caution

✗ : Microwave unsafe

Operations

Control panel

The front panel comes in a wide range of materials and colors. For improved quality, the actual appearance of the oven is subject to change without notice.

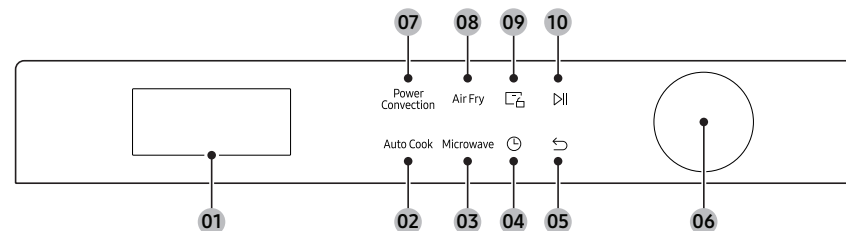

01 Display	Shows necessary information for selected function or settings.
02 Auto Cook	To select custom dishes.
03 Microwave	To select microwave mode.
04 Cook Time	To set change cooking times during cooking.
05 ↶ Button	To return to previous stage or default mode.
06 Dial	To set the mode or adjust auto cook, time, weight, temp, etc. You can turn left of right, and press to select.
07 Power Convection	To select Power Convection mode.
08 Air Fry	To select Air Fry mode.
09 Door Unlock	To open the Door.
10 Start/Stop Button	To start or stop cooking.

Operations

System Settings

You can customize your new microwave oven to suit your preferences.

To customize:

1. Use the Dial to find and select **Setting**.
2. Use the Dial to select a function you want to customize.
3. Use the Dial to select desired option.

The functions and options are listed in the table below.

Function	Description	Options
My Pattern	The My Pattern function can be turned on or off. It will let you see the most used cooking mode first on the display.	On
		Off
Sounds	The Sound can be turned on or off.	On
		Off
Screen Saver	Screen Saver options are 5 min, 10 min, and 15 min.	5 min.
		10 min.
		15 min.
Use 24-hour Format	The clock can display in either the 12 hr or 24 hr time mode.	12 hr
		24 hr
Language	You can choose the Language of your microwave oven.	English
		French
Smart Control	You can use the SmartThings app to make the most out of smarter living.	On
		Off
Wi-Fi	The Wi-Fi function can be turned on or off.	On
		Off
Factory Reset	You can reset to factory default settings. All of the data will be erased permanently.	-

NOTE

Standby state: After 3 minutes of inactivity on the control panel, the oven enters the Standby state where only the current time is displayed. After 10 more minutes of inactivity or touch , the oven enters the Stop state.

Feature overview

Feature		Temp./ Power range	Default Temp./ Power	Max. time
Manual mode	Power Convection	300 - 450 °F	400 °F	60 min.
		Power Convection is similar to Convection mode. However, the heating elements generate stronger heat and distribute stronger air current inside the oven. This is designed to cook food faster while keeping or improving the taste.		
	Convection	100 - 450 °F	350 °F	60 min.
		The heating elements generate heat, which is evenly distributed inside the oven by the convection fan. Use this mode for frozen food or baking.		
	Air Fry	300 - 450 °F	400 °F	60 min.
		You can cook using air fry mode.		
	Microwave	10 - 100 %	100 %	90 min.
		The microwave energy enables food to be cooked or reheated without changing either the form or the color.		
	Grill	-	-	60 min.
		Use this for grilling food such as meat.		
Combi	Grill Combi	10 - 70 %	70 %	60 min.
		The heating elements generate heat, which is reinforced by microwave energy.		
	Convection Combi	100 - 400 °F	350 °F	60 min.
10 - 70 %		70 %		
		The heating elements generate heat and the convection fan distributes the heat inside the oven, which is reinforced by microwave energy.		
Auto mode	Auto Cook	For cooking beginners, the oven offers a total of 44 auto cooking programs.		
	Defrost	The oven offers 4 defrosting programs for your convenience.		

Feature		Temp./ Power range	Default Temp./ Power	Max. time
Special functions	Keep Warm	125 - 175 °F	150 °F	3 hrs.
		Use this only for keeping food you have just cooked warm.		
	Recent Recipes	Up to 10 recently cooked custom cooking lists and detailed options are saved.		
	Favorites	You can save your favorite recipies.		
Deodorization	-	-	15 min.	
	Use to reduce the smell of food inside after cooking.			

Smart control

To use the microwave oven's Smart Control, you must download the SmartThings app to a mobile device.

Functions operated by the SmartThings app may not work smoothly if communication conditions are poor or the microwave oven is installed in a place with a weak Wi-Fi signal.

How to connect the microwave oven

1. Download and open the SmartThings app on your smart device.
2. Follow the app's on-screen instructions to connect your microwave oven.
3. To operate smart control function from the microwave oven, use the **Dial** to turn Smart Control function on.
4. Once the process is complete, the  icon appears on your microwave oven display and the app will confirm you are connected.
5. If the connection icon does not turn on, follow the instruction on the app to reconnect.

Microwave Oven remote control using the SmartThings app	
Microwave Oven Monitoring	Check the status of the microwave oven

NOTE

- For safety reasons, you cannot turn on the microwave oven remotely and you must specify the cooking time to enable remote control.
- Smart Control will not work properly if the Wi-Fi Connection is unstable.

Voice control

To use the microwave oven's Voice Control function, you need Bixby / Amazon Alexa App / Google Assistant App on your mobile device.

Bixby

Start conversation with Bixby on Samsung mobile by saying "Hi Bixby" or by pressing the side key.

Function	Bixby Command		
Turn Off/Stop	<ul style="list-style-type: none"> • Cancel the microwave • Turn off the microwave 		
Check Time	<ul style="list-style-type: none"> • Check the remaining time of the microwave • How much time is left on the microwave timer? 		
Check Status	<ul style="list-style-type: none"> • Check the microwave status • Check the status of the microwave 		
Send Auto Cook Recipe	<ul style="list-style-type: none"> • Cook pizza • Heat pizza • I want to cook pizza • Can you cook pizza? 	<ul style="list-style-type: none"> • Cook pizza for 2 • Heat pizza for 2 • I want to cook pizza for 2 • Can you cook pizza for 2? 	<ul style="list-style-type: none"> • Cook 2 slices of pizza • Heat 2 slices of pizza • I want to cook 2 slices of pizza • Can you cook 2 slices of pizza?

Operations

Amazon Alexa & Google Assistant

Samsung smart home appliances are supported by SmartThings skill in Alexa & action in Google Assistant.

Installation Guide

Here's how to link SmartThings account into Amazon Alexa or Google Assistant. SmartThings App and Alexa App (or Google Assistant App) Should be installed on your phone.

1. Setup the supported devices to SmartThings.
2. After device setup, tap + button on the screen.
3. Tap **Voice assistant** and link your Samsung account to Amazon Alexa. (or Google Assistant)
4. Check the devices are visible on Amazon Alexa app. Then account linking is complete. (Check the devices are visible and set the location(home&room) of devices in Google home app. Then account linking is complete.)

Function	'Alexa'	'OK Google'
Turn Off/Stop	<ul style="list-style-type: none"> • Turn off the microwave • Stop the microwave 	<ul style="list-style-type: none"> • Turn off the microwave • Stop the microwave
Check Status	<ul style="list-style-type: none"> • Is the microwave running? • Is the microwave on? 	<ul style="list-style-type: none"> • Is the microwave running? • Is the microwave on?
Send Auto Cook Recipe	<ul style="list-style-type: none"> • Cook pizza • Heat pizza • I want to cook pizza • Can you cook pizza? 	<ul style="list-style-type: none"> • Cook pizza for 2 • Heat pizza for 2 • I want to cook pizza for 2 • Can you cook pizza for 2?
		<ul style="list-style-type: none"> • Cook 2 slices of pizza • Heat 2 slices of pizza • I want to cook 2 slices of pizza • Can you cook 2 slices of pizza?

NOTE

- For safety reasons, you cannot turn on the microwave oven remotely.
- Below table is available menu for **Send Auto Cook Recipe** function.

Food	Amount	Instructions
Popcorn	3.0 oz	Use oven popcorn. Follow the instructions on the packaging. Place the pack on the center of the turntable. Be careful when removing the heated bag from the oven and opening it.
	3.5 oz	
Potatoes	2 potatoes	Pierce the potatoes 3 times with a fork. Place the potatoes around the plate or turntable in a spoke-like fashion. After cooking, let the potatoes stand for 3 - 5 minutes.
	4 potatoes	
Pizza	2 slices	Place the pizza slices on a oven-safe plate with the wide ends of the slices towards the outside edge of the plate. Do not let the slices overlap. Do not cover.
	4 slices	
Spinach	2 servings	Wash and clean the spinach. Place the spinach in a oven safe bowl. Add 1 - 4 tablespoons of water (1 Tbsp per serving). Cover with vented (1 inch vent) plastic wrap while cooking. stir afterwards.
	4 servings	
Brown Rice	1 serving	Place 1/2 cup brown rice and 1 cup water for 1 serving in a oven safe bowl. Stir well before and fluff with a fork afterwards. Let stand 5 minutes before serving.
	2 servings	
Fresh Fish Fillets	1 serving	Place the fish fillets on the oven safe dish. Cover with vented(1 inch vent) plastic wrap while cooking and stir before letting stand. Place the dish on the center of the turntable.
	2 servings	
Chicken Nuggets	1 serving	Distribute frozen chicken nuggets evenly on the crusty plate. Place food on a crusty plate and place it on the high rack. Serve with Dijon mustard, ranch dressing or your favorite dipping sauce.
	2 servings	
French Fries	1 serving	Distribute frozen thick french fries evenly on the crusty plate. Place food on a crusty plate and place it on the high rack. Serve with Ketchup or Dijon mustard.
	2 servings	
Melt Butter	1 stick	Remove the wrapping and cut the butter in half vertically. Place the butter in a dish and cover with wax paper. Stir well after finishing and let stand for 1 - 2 minutes.
	2 sticks	
Soften Cream Cheese	1 pack	Unwrap the cream cheese and place on a oven-safe container.

Manual mode

1. Select mode

Use the **Dial** to select mode. For example, **Convection**.

If you select **Combi** mode, one of these indicators is displayed:

- Grill Combi (Microwave + Grill)
- Convection Combi (Microwave + Convection)

2. Set temperature or Power level

Use the **Dial** to adjust the default temperature (or power level). When done, press **Dial** to move to the time elements.

3. Set cooking time

Use the **Dial** to set the cooking time. When done, press **Dial** or touch **▶||** button.

NOTE

- For Microwave mode, step 3 proceeds before step 2.
- You can set cooking time after preheating is done.

4. Preheat

The oven starts preheating until it reaches the set temperature.

CAUTION

- Always use oven gloves while taking out food.
- The microwave fan may continue to operate for 5 minutes after cooking if the temperature in the oven cavity is too hot.

To change the cooking time during cooking

- For Microwave mode, turn the **Dial** to adjust the cooking time.
- For Oven modes, use the **Dial** to select cooking time on display and adjust the cooking time. Press the **Dial** again to confirm the change and the oven will resume cooking with the new settings.

To change the temperature during cooking

- Use the **Dial** to select temperature on display and adjust the temperature. Press the **Dial** again to confirm the change.
- Power level can not be changed during cooking.

To pause or cancel operation

Press **Dial** or touch **▶||** button once to pause operation, and twice to resume.

To cancel the operation, touch **↶** and select yes.

Power Convection

Power Convection is similar to the Convection mode. However, the heating elements generate higher temperature heat and the fan generates stronger air currents inside the oven.

This mode is designed to cook faster while keeping or improving the taste. You can use the Low rack or a combination of the Low rack and Crusty plate on the turntable.

Select	>	Set	>	Set	>	Start
Power Convection		Temperature		Cooking time		Preheating

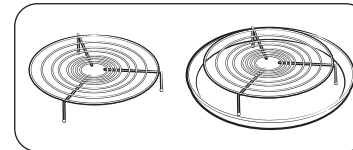

1. Put the Low rack or the combination of the Low rack and Crusty plate on the turntable.

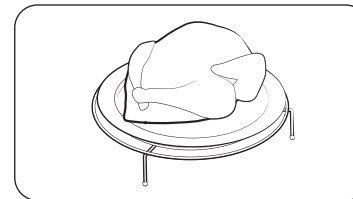

2. Put food in suitable cookware, then put the cookware on the rack and close the door.
3. Follow steps shown in the table above.
4. When cooking is complete, "Cooking finished!" appears. Use oven gloves to take out food.

Operations

⚠ CAUTION

Do not use this mode for baking breads, or cooking confectionery. The stronger heat can burn the tops of food.

📖 NOTE

When you touch ▶|| to start after setting the temperature, preheating will start.

Convection

The heating elements generate heat, which is evenly distributed inside the oven by the convection fan. You can use the Low rack or a combination of the Low rack and Crusty plate on the turntable. Use this mode for biscuits, individual scones, rolls, and cakes as well as fruit cakes, choux pastries, and soufflés.

Select > Set > Set > Start
Convection Temperature Cooking time Preheating

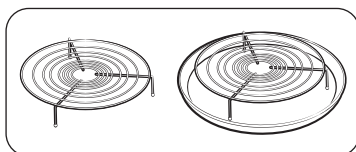

1. Put the Low rack or the combination of the Low rack and Crusty plate on the turntable.

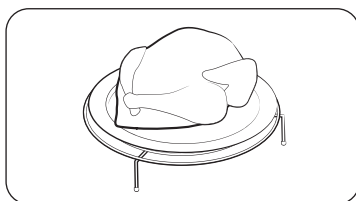

2. Put food in suitable cookware, then put the cookware on the rack and close the door.
3. Follow steps shown in the table above.
4. When cooking is complete, "Cooking finished!" appears. Use oven gloves to take out food.

📖 NOTE

When you touch ▶|| to start after setting the temperature, preheating will start.

Air Fry

The Air Fry function allows you to fry food crispy without oil. Use a high rack for thin dishes and a low rack for thick dishes.

Select > Set > Set > Start
Air Fry Temperature Cooking time Preheating

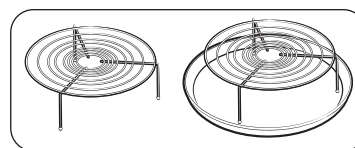

1. Put the High, Low rack or the combination of the High, Low rack and Crusty plate on the turntable.

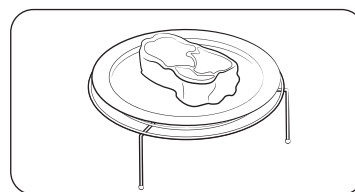

2. Put food in suitable cookware, then put the cookware on the rack and close the door.
3. Follow steps shown in the table above.
4. When cooking is complete, "Cooking finished!" appears. Use oven gloves to take out food.

📖 NOTE

When you touch ▶|| to start after setting the temperature, preheating will start.

Microwave

Microwaves are high-frequency electromagnetic waves. The microwave energy cooks or reheats food without changing either the form or the color.

- Use only microwave-safe cookware.

Select > Set > Set > Start
 Microwave > Cooking time > Power level

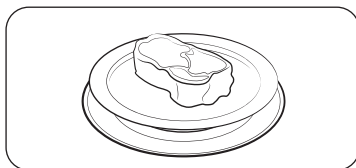

1. Put food in a microwave-safe container, and then place the container in the center of the turntable. Close the door.
2. Follow steps shown in the table above.

NOTE

- For Microwave mode, step 3 proceeds before step 2.
3. When cooking is complete, "Cooking finished!" appears. Use oven gloves to take out food.

Power level

100 %	High	50 %	Medium
90 %	Sauté	40 %	Medium low
80 %	Reheat	30 %	Low
70 %	Medium high	20 %	Defrost
60 %	Simmer	10 %	Warm

Grill

The heating elements generate heat. Make sure they are in the horizontal position.

Select > Set > Start
 Grill > - > Cooking time

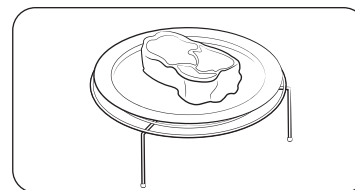
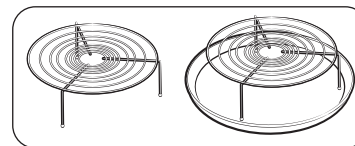

1. Put the High rack or the combination of High rack and Crusty plate on the turntable.
2. Put food in suitable cookware, then put the cookware on the rack and close the door.
3. Follow steps shown in the table above.
4. When cooking is complete, "Cooking finished!" appears. Use oven gloves to take out food.

Operations

Combi - Grill Combi

The heating elements generate heat, which is reinforced by the microwave energy. Use only microwave-safe cookware, such as glass or ceramic cookware.

Select > Set > Set > Start
Combi > Grill Combi Power Level Cooking Time

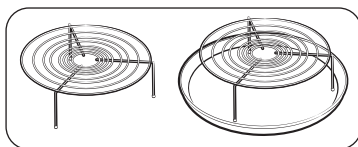

1. Put the High rack or the combination of High rack and Crusty plate on the turntable.

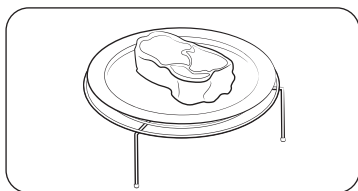

2. Put food in suitable cookware, then put the cookware on the rack and close the door.
3. Follow steps shown in the table above.
4. When cooking is complete, "Cooking finished!" appears. Use oven gloves to take out food.

⚠ CAUTION

Use only ovenproof cookware, such as cookware made out of glass, pottery, or bone china without metal trim.

Combi - Convection Combi

This combination mode combines microwave energy with hot air, resulting in reduced cooking time and producing a brown, crispy surface on the food. Use this mode for all kinds of meat and poultry as well as casseroles and gratin dishes, sponge cakes and light fruit cakes, pies and crumbles, roast vegetables, scones, and breads.

Select > Set > Set > Start
Combi > Convection Combi Temperature and Power Level Cooking Time Preheating

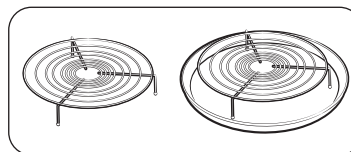

1. Put the Low rack or the combination of the Low rack and Crusty plate on the turntable.

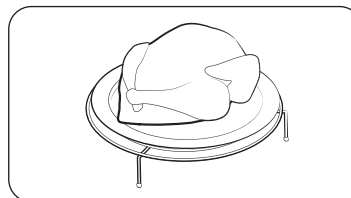

2. Put food in suitable cookware, then put the cookware on the rack and close the door.
3. Follow steps shown in the table above.
4. When cooking is complete, "Cooking finished!" appears. Use oven gloves to take out food.

⚠ CAUTION

Use only ovenproof cookware, such as cookware made out of glass, pottery, or bone china without metal trim.

Auto mode

The oven offers 2 different auto modes for your convenience: **Auto Cook** and **Defrost**. Select one that best fits your needs.

1. Select mode

Use the Dial to find and select mode. For example, **Auto Cook**.

2. Select category

Use the Dial to select category. For example **Auto Air Fry**.

3. Select food

Use the Dial to select a preferred program, and then press the **Dial**.

4. Set serving size or weight

Use the Dial to set the serving size (or weight). When done, press the **Dial** or touch **>||** button.

CAUTION

Always use oven gloves when taking out food.

NOTE

The cooking time is pre-programmed according to the auto mode and cannot be changed.

Auto Cook

For cooking beginners, the oven offers a total of 44 auto cooking programs. Take advantage of this feature to save time or shorten your learning curve. The cooking time and temperature will be adjusted according to the selected recipe.

Start	>	Set	>	Set	>	Set
Auto Cook		Category		Food		Serving Size

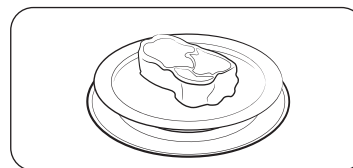

1. Put food in suitable cookware, then put the cookware on the turntable and close the door.
2. Follow steps shown in the table above.
3. When cooking is complete, "Cooking finished!" appears. Use oven gloves to take out food.

Defrost

The oven offers 4 defrosting programs for your convenience. The time and power levels are automatically adjusted according to the selected program.

Start	>	Set	>	Set	>	Set
Defrost		Category		-		Weight

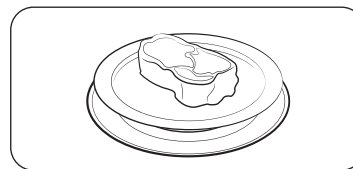

1. Put food in suitable cookware, then put the cookware on the turntable and close the door.
2. Follow steps shown in the table above.
3. When defrosting is complete, "Cooking finished!" appears. Use oven gloves to take out food.

Operations

Special functions

Keep Warm

With this function, only the convection heating element operates, and it cycles on and off to keep food warm.

1. Use the **Dial** to select **Keep Warm**. The default temperature (150 °F) appears.
2. Use the **Dial** to adjust the temperature, and then press the **Dial** to move to the time element. If you touch **▷||**, oven will start warming with 30 minutes setting.
3. Use the **Dial** to set the time, and then press the **Dial** or touch **▷||** button. The oven starts warming.

CAUTION

- Always use oven gloves while taking out food.
- Do not use this function to reheat cold foods. Use this only to keep food that has been cooked warm.
- To keep food crispy, do not cover the food.

NOTE

- To change the temperature or cooking time during the cycle, use the **Dial** to select temperature or cooking time on display and adjust. Press the **Dial** again to confirm the change.
- See the table for **Keep Warm** temperature settings.

Keep Warm guide

Food	Temperature (°F)	Standing time (min.)	Directions
Meals	175	30	For keeping meat, chicken, gratin, pizza, potatoes, and plated meals warm.
Drinks	175	30	For keeping water, milk, and coffee warm.
Breads/ Pastries	150	30	For keeping bread, toast, rolls, muffins, and cake warm.

Food	Temperature (°F)	Standing time (min.)	Directions
Dishes/ Crockery	150	30	For preheating dishes and crockery. Arrange the dishes over the turntable. Do not overload. (Maximum load: 15 lbs. / 7 kg)

Recent Recipes

Up to 10 recently cooked custom cooking lists and detailed options are saved.

The **Recent Recipes** appear only when customized cooks are used in the product or app.

1. Use the **Dial** to find and select **Recent Recipes**.
2. Use the **Dial** to choose desired cook from saved list.
 - If you want a quick start, touch the **▷||** button. Cooking starts right away.

Favorites

You can save your favorite recipes.

1. Use the **Dial** to find and select **Favorites**.
2. You can add, edit or delete favorite recipes. To add a new recipe, select cooking mode, temperature or power level and cooking time and then save it.
3. Use the **Dial** to choose desired cook from saved list.

Deodorization

Deodorization helps remove bad smells from inside the oven after cooking.

1. Use the **Dial** to find and select **Deodorization** at **Setting**.
2. Use the **Dial** to set time. The default time is 5 minutes. (max: 15 min)
3. Press the **Dial** or touch **▷||** button to start **Deodorization**.

Cooking Smart

Auto Mode

Auto Cook guide

Category	Food	Amount	Instructions
Auto Air Fry	Frozen Thin French Fries	6 oz	Distribute frozen thin french fries evenly on the crusty plate. Place food on a crusty plate and place it on the high rack.
		12 oz	
	Frozen Thick French Fries	8 oz	Distribute frozen thick french fries evenly on the crusty plate. Place food on a crusty plate and place it on the high rack.
		16 oz	
	Frozen Potato Wedges	8 oz	Distribute frozen potato wedges evenly on the crusty plate. Place food on a crusty plate and place it on the high rack.
		16 oz	
	Frozen Tator Tots	8 oz	Distribute frozen tator tots evenly on the crusty plate. Place food on a crusty plate and place it on the high rack.
		16 oz	
	Homemade French Fries	8 oz	Use hard to medium type of potatoes and wash them. Peel potatoes and cut into sticks with a thickness of 10 x 10 mm. Soak in cold water (for 30 min.). Dry them with a towel, weigh them and brush with 5 g olive oil and spices. Distribute homemade fries evenly on the crusty plate. Place food on a crusty plate and place it on the high rack.
			16 oz
	Homemade Wedge Potatoes	10 oz	Wash normal sized potatoes and cut them into wedges. Brush with olive oil and spices. Weigh them and brush with 5 g olive oil and spices. Put them with the cut side on the crusty plate. Place food on a crusty plate and place it on the high rack.
		20 oz	
	Frozen Chicken Nuggets	8 oz	Distribute frozen chicken nuggets evenly on the crusty plate. Place food on a crusty plate and place it on the high rack.
		16 oz	
	Frozen Chicken Wings	8 oz	Distribute frozen chicken wings evenly on the crusty plate. Place food on a crusty plate and place it on the high rack.
		16 oz	
Frozen Chicken Tenders	8 oz	Distribute frozen chicken tenders evenly on the crusty plate. Place food on a crusty plate and place it on the high rack.	
	16 oz		
Chicken Wings	10 oz	Weigh the chicken wings and brush them with oil and spices. Place food on a crusty plate and place it on the high rack.	
	20 oz		
Chicken Drumsticks	12 oz	Weigh the drumsticks and brush them with oil and spices. Place food on a crusty plate and place it on the high rack.	
	24 oz		

Category	Food	Amount	Instructions
Auto Air Fry	Frozen Cheese Sticks	8 oz	Distribute frozen cheese sticks evenly on the crusty plate. Place food on a crusty plate and place it on the low rack.
		16 oz	
	Frozen Onion Rings	7 oz	Distribute frozen onion rings evenly on the crusty plate. Place food on a crusty plate and place it on the high rack.
		14 oz	
	Frozen Prawns	8 oz	Distribute frozen breaded prawns evenly on the crusty plate. Place food on a crusty plate and place it on the high rack.
16 oz			
Frozen Soft Pretzels	2 ea	Distribute frozen soft pretzels evenly on the crusty plate. Place food on a crusty plate and place it on the low rack.	
	4 ea		
Cook	Bone-In Chicken Pieces	18 oz	Brush the chicken pieces with oil and seasonings. Place the pieces skin side down on the high rack. When the oven beeps, turn over chicken pieces and press start to continue.
		36 oz	
	Boneless Pork Chops	2 ea	Brush the boneless pork chops with oil and seasonings. Place the pork chops on the high rack. When the oven beeps, turn over pork chops and press start to continue.
		4 ea	
	Hamburger	2 ea	Place the hamburgers on the high rack. When the oven beeps, turn over the hamburgers and press start to continue.
		4 ea	
	Sirloin Steak	Medium	Brush the Steaks with oil and seasonings. Place the steak on the high rack. When the oven beeps, turn over the steak and press start to continue. Let the steak rest for 5 minutes before slicing. As your taste.
		Welldone	
	Salmon Fillets	1 ea	Brush the salmon fillets with oil and seasonings. Place the salmon fillets on the high rack.
		2 ea	
Frozen Pizza	6 inch	Place the pizza on the high rack.	
	12 inch		
Roasted Vegetables	8 oz	Cut vegetables 0.5 inch thick and brush them with oil and seasonings. Place vegetables on the crusty plate and place it on the high rack.	
	16 oz		

Cooking Smart

Category	Food	Amount	Instructions
Snacks	Popcorn	1.5 oz	Heat only one microwave popcorn bag at a time. Place the popcorn in the center of the turntable. Be careful when removing the heated bag from the oven and opening it.
		3.0 oz	
		3.5 oz	
	Bacon	2 ea	Layer paper towels on the plate and arrange bacon on the towels. Place bacon on the microwave safe dish. Do not overlap bacon. Cover with an additional paper towel. Remove the paper towel immediately after cooking.
		4 ea	
		6 ea	
	Hot Dogs	2 ea	Pierce the hot dogs 3 times with a fork. Place hot dogs on the microwave safe dish. When the oven beeps, add the buns and press start to continue.
		4 ea	
	Oatmeal	1 pack	Follow the package directions for the recommended amount of water needed. Place the oatmeal in the microwave safe bowl. Stir afterwards.
		2 packs	
Nachos	1 serving	Arrange the tortilla chips uniformly on a crusty plate and sprinkle cheese evenly. Place chips on the crusty plate and place it on the high rack.	
Brownie mix	1 pack	Pour the batter into an 8 * 8 inch pan. Place the pan on the lower rack.	
Cookie Dough	8 ea	Preheat the oven. Place 8 cookies on the crusty plate, then place it on the low rack. When the oven beeps, put the cookies and press start to continue.	

Category	Food	Amount	Instructions
Soften/ Melt	Melt Butter	1 stick	Remove the wrapping and cut the butter in half vertically. Place the butter in a dish and cover with wax paper. Stir well after finishing and let stand for 1 - 2 minutes.
		2 sticks	
	Soften Butter	1 stick	Remove the butter from the packaging and place on a microwave safe dish.
		2 sticks	
	Melt Chocolate	1 cup	Place the chocolate chips or squares in a microwave safe bowl. When the oven beeps, stir well and press start to continue. Stir well after finishing and let stand for 1 - 2 minutes. Unless stirred, the chocolate chips will keep their shape even when the heating time is over.
	Soften Ice Cream	1 pint	Remove the lid of the carton. Place the carton in the center of the oven.
		Half Gallon	
	Soften Cream Cheese	8 oz	Unwrap the cream cheese and place on a microwave-safe container.
	Melt Cheese	1 cup	Place the cheese in a microwave safe bowl and cover with wax paper. Stir well afterwards.
Melt Marshmallows	10 oz	Place the marshmallows in a large microwave safe dish. Stir well afterwards.	

Category	Food	Amount	Instructions
Reheat	Beverage	1 cup	Use a measuring cup or mug and do not cover. Put the cup in the center of the turntable. Stir well afterwards.
		2 cups	
	Pizza Reheat	2 ea	Place the pizza on a microwave safe plate. Do not overlap the slices or cover. Let stand 1 - 2 minutes before serving.
		4 ea	
	Soup	8 oz	Pour the refrigerated soup into a microwave safe bowl. Cover with a lid or vented plastic wrap. Let stand 1 - 2 minutes before serving.
		16 oz	
		24 oz	
		32 oz	
	Pasta	8 oz	Pour the refrigerated pasta into a microwave safe bowl. Cover with a lid or vented plastic wrap. Let stand 1 - 2 minutes before serving.
		16 oz	
		24 oz	
		32 oz	
	Casserole	8 oz	Pour the refrigerated casserole into a microwave safe bowl.
		16 oz	
		24 oz	
32 oz			
Dinner plate	1 serving	Use only precooked, refrigerated foods. Place dinner plate on the turntable. Cover with vented(1 inch vent) plastic wrap while cooking. Let stand 1 - 2 minutes before serving.	
Frozen Breakfast	5 oz	Remove the outer wrapping and follow the package directions for covering. When oven beeps, stir and press start to continue. Let stand 1 - 2 minutes before serving.	
	8 oz		
Frozen Dinner	8 oz	Remove the outer wrapping and follow the package directions for covering. Let stand 1 - 2 minutes before serving.	
	12 oz		
	16 oz		

Defrost guide

Food	Amount (lbs.)	Directions
Meat	0.1 - 3.5	Shield the edges with aluminium foil. Turn the meat over when the oven beeps. This program is suitable for lamb, pork, steaks, chops, and ground meat. For ground meat, place the meat directly on the turntable tray on wax paper. Do not use an extra tray. Let stand, covered with foil, for 5 - 10 minutes.
Poultry	0.1 - 3.5	Shield the leg and wing tips with aluminium foil. Turn the poultry over when the oven beeps. This program is suitable for whole chicken as well as for chicken portions.
Fish	0.1 - 3.5	Shield the tail of a whole fish with aluminium foil. Turn the fish over when the oven beeps. This program is suitable for whole fish as well as for fish fillets.
Bread/Cake	0.1 - 2.0	Put bread on a piece of paper towel. Turn over as soon as the oven beeps. Place cake on a ceramic plate and if possible, turn over as soon as the oven beeps. (The oven keeps operating and stops only when you open the door.) This program is suitable for all kinds of bread, sliced or whole, as well as for bread rolls and baguettes. Arrange bread rolls in a circle.

Cooking Smart

Manual cooking

Microwave cooking guide

- Do not use metal containers with Microwave mode. Always put food containers on the turntable.
- It is recommended to cover the food for best results.
- After cooking is complete, let the food settle in its own steam.

Frozen vegetables

- Use a glass Pyrex container with a lid.
- Stir vegetables twice during cooking, and once after cooking.
- Add seasoning after cooking.

Food	Amount (lb.)	Power (%)	Cooking time (min.)	Standing time (min.)
Spinach	0.3	60	5 - 6	2 - 3
	Add 15 ml (1 tbsp.) of cold water.			
Broccoli	0.7	60	8 - 9	2 - 3
	Add 30 ml (2 tbsp.) of cold water.			
Peas	0.7	60	7 - 8	2 - 3
	Add 15 ml (1 tbsp.) of cold water.			
Green Beans	0.7	60	7 ½ - 8 ½	2 - 3
	Add 30 ml (2 tbsp.) of cold water.			
Mixed Vegetables (Carrots, Peas, Corn)	0.7	60	7 - 8	2 - 3
	Add 15 ml (1 tbsp.) of cold water.			
Mixed Vegetables (Chinese Style)	0.7	60	7 ½ - 8 ½	2 - 3
	Add 15 ml (1 tbsp.) of cold water.			

Fresh vegetables

- Use a glass Pyrex container with a lid.
- Add 30 - 45 ml of cold water (2 - 3 tbsp.) for every 0.6 lbs.
- Stir once during cooking, and once after cooking.
- Add seasoning after cooking.
- For faster cooking, it is recommended to cut into smaller, even sizes.
- Cook all fresh vegetables using full microwave power (900 W).

Food	Amount	Power (%)	Cooking time (min.)	Standing time (min.)
Broccoli	0.6 lb. 1.0 lbs.	100	3 - 4 5 - 6	3
	Prepare even sized florets. Arrange the stems so they point to the center.			
Brussels Sprouts	1.0 lbs.	100	4 ½ - 5	3
	Let stand 60-75 ml (5-6 tbsp.) water.			
Carrots	1.0 lbs.	100	6 - 7	3
	Cut carrots into even sized slices.			
Cauliflower	0.6 lb. 1.0 lbs.	100	3 ½ - 4 6 - 7	3
	Prepare even sized florets. Cut big florets in half. Arrange stems so they point to the center.			
Zucchini	0.6 lb.	100	4 - 5	3
	Cut zucchini into slices. Add 30 ml (2 tbsp.) water or a knob of butter. Cook until just tender.			
Eggplant	0.6 lb.	100	2 ½ - 3	3
	Cut eggplant into small slices and sprinkle with 1 tbsp. lemon juice.			

Food	Amount	Power (%)	Cooking time (min.)	Standing time (min.)
Leeks	0.6 lb.	100	3 ½ - 4	3
	Cut leeks into thick slices.			
Mushrooms	0.25 lb. 0.6 lb.	100	1 ½ - 2 2 ½ - 3	3
	Prepare small whole or sliced mushrooms. Do not add any water. Sprinkle with lemon juice. Spice with salt and pepper. Drain before serving.			
Onions	0.6 lb.	100	5 - 5 ½	3
	Cut onions into slices or halves. Add only 15 ml (1 tbsp.) water.			
Pepper	0.6 lb.	100	4 ½ - 5	3
	Cut pepper into small slices.			
Potatoes	0.6 lb. 1.0 lbs.	100	5 - 6 8 - 9	3
	Weigh the peeled potatoes and cut them into similar sized halves or quarters.			
Turnip Cabbage	0.6 lb.	100	5 ½ - 6	3
	Cut turnip into small cubes.			

Rice and Pasta

Stir from time to time during and after cooking.

Cook uncovered, and close the lid during settling. Then, drain water thoroughly.

- **Rice:** Use a large glass Pyrex container with a lid against the rice doubling in volume.
- **Pasta:** Use a large glass Pyrex container.

Food	Amount	Power (%)	Cooking time (min.)	Standing time (min.)
White Rice (Parboiled)	1 cup	60	19 - 21	5
	Add 2 cups of cold water for 1 cup of rice.			
	1 ½ cups	60	21 - 23	5
	Add 3 cups of cold water for 1 ½ cups of rice.			
Brown Rice (Parboiled)	1 cup	60	22 - 24	5
	Add 2 cups of cold water for 1 cup of rice.			
	1 ½ cups	60	24 - 26	5
	Add 3 cups of cold water for 1 ½ cups of rice.			
Mixed Rice (Rice + Wild Rice)	1 cup	80	16 - 17	5
	Add 2 cups of cold water for 1 cup of rice/wild rice mix.			
Mixed Corn (Rice + Grain)	1 cup	80	17 - 18	5
	Add 1¾ cups of cold water to 1 cup of mixed rice/grain.			
Pasta	1 cup	80	10 - 11	5
	Add 4 ¼ cups of water.			

Cooking Smart

Reheating

- Do not reheat large-sized foods such as joints of meat, which easily overcook.
- It is safer to reheat foods at lower power levels.
- Stir well or turn over during and after cooking.
- Use caution for liquids or baby foods. Stir well before, during, and after cooking with a plastic spoon or glass stirring stick to prevent eruptive boiling and scalding. Keep them inside the oven during the standing time. Allow a longer reheating time than other food types.
- Recommended standing time after reheating is 2 - 4 minutes. See the table below for reference.

Liquids

Food	Amount	Power (%)	Cooking time (min.)	Standing time (min.)
Drinks (Coffee, Tea, Water)	150 ml (1 cup) 300 ml (2 cups) 450 ml (3 cups) 600 ml (4 cups)	100	1 - 1 ½ 2 - 2 ½ 3 - 3 ½ 4 - 4 ½	1 - 2
	Pour into cups and reheat uncovered: 1 cup in the center, 2 cups opposite of each other, 3 cups in a circle. Keep in microwave oven during standing time and stir well.			
Soup (Chilled)	0.6 lb. 0.8 lb. 1.0 lbs. 1.2 lbs.	70	3 ½ - 4 4 ½ - 5 6 - 6 ½ 7 - 7 ½	2 - 3
	Pour into a deep ceramic plate or deep ceramic bowl. Cover with a plastic lid. Stir well after reheating. Stir again before serving.			
Stew (Chilled)	0.8 lb.	70	4 ½ - 5 ½	2 - 3
	Put stew in a deep ceramic plate. Cover with a plastic lid. Stir occasionally during reheating and again before standing and serving.			

Food	Amount	Power (%)	Cooking time (min.)	Standing time (min.)
Pasta With Sauce (Chilled)	0.8 lb.	70	3 ½ - 4 ½	3
	Put pasta (e.g. spaghetti or egg noodles) on a flat ceramic plate. Cover with microwave cling film. Stir before serving.			
Filled Pasta With Sauce (Chilled)	0.8 lb.	70	4 - 5	3
	Put filled pasta (e.g. ravioli, tortellini) in a deep ceramic plate. Cover with a plastic lid. Stir occasionally during reheating and again before standing and serving.			
Plated Meal (Chilled)	0.8 lb. 1.0 lbs. 1.2 lbs.	60	4 ½ - 5 ½ 5 ½ - 6 ½ 6 ½ - 7 ½	3
	Plate a meal of 2-3 chilled components on a ceramic dish. Cover with microwave cling-film.			
Cheese Fondue Ready-to-Serve (Chilled)	0.8 lb.	60	6 - 7	1 - 2
	Put the ready-to-serve cheese fondue in a suitable sized glass Pyrex bowl with lid. Stir occasionally during and after reheating. Stir well before serving.			

Baby foods & Milk

Food	Amount	Power (%)	Cooking time (sec.)	Standing time (min.)
Baby Food (Vegetables + Meat)	0.4 lb.	70	30	2 - 3
	Empty into ceramic deep plate. Cook covered. Stir after cooking time. Before serving, stir well and check the temperature carefully.			
Baby Porridge (Grain + Milk + Fruit)	0.4 lb.	70	20	2 - 3
	Empty into ceramic deep plate. Cook covered. Stir after cooking time. Before serving, stir well and check the temperature carefully.			
Baby Milk	100 ml 200 ml	30	30 - 40 60 - 70	2 - 3
	Stir or shake well and pour into a sterilized glass bottle. Place in the center of turntable. Cook uncovered. Shake well and let stand for at least 3 minutes. Before serving, shake well and check the temperature carefully.			

Defrost

Put frozen food in a microwave-safe container without a cover. Turn over during defrosting, and drain off liquid and remove giblets after defrosting. For faster defrosting, cut the food into small pieces, and wrap them with aluminum foil before defrosting. When the outer surface of frozen foods begins to melt, stop defrosting and let stand as instructed in the table below. Do not change the default power level (20 %) for defrosting.

Food	Amount	Power (%)	Defrosting time (min.)	Standing time (min.)	
Meat	Minced Beef	0.6 lb. 1.1 lbs.	20	6 - 7 8 - 13	15 - 30
	Pork Steaks	0.6 lb.		7 - 8	
	Place the meat on the turntable. Shield thinner edges with aluminium foil. Turn over after half of defrosting time!				
Poultry	Chicken Pieces	1.1 lbs. (2 pcs)	20	14 - 15	15 - 60
	Whole Chicken	2.7 lbs.		32 - 34	
	First, put chicken pieces first skin-side down, whole chicken first breast-side-down on a flat ceramic plate. Shield the thinner parts like wings and ends with aluminium foil. Turn over after half of defrosting time!				
Fish	Fish Fillets	0.4 lb.	20	6 - 7	10 - 25
	Whole Fish	0.9 lb.		11 - 13	
	Put frozen fish in the middle of a flat ceramic plate. Arrange the thinner parts under the thicker parts. Shield narrow ends of fillets and tail of whole fish with aluminium foil. Turn over after half of defrosting time!				
Fruit	Berries	0.7 lb.	20	6 - 7	5 - 10
	Spread fruit on a flat, round glass dish (with a large diameter).				

Cooking Smart

Food		Amount	Power (%)	Defrosting time (min.)	Standing time (min.)
Bread	Bread Rolls (each ca. 50 g)	2 pcs 4 pcs	20	1 - 1 ½ 2 ½ - 3	5 - 20
	Toast/Sandwich	0.6 lb.		4 - 4 ½	
	German Bread (Wheat + Rye Flour)	1.1 lbs.		7 - 9	
	Arrange rolls in a circle or bread horizontally on kitchen paper in the middle of turntable. Turn over after half of defrosting time!				

Grilling guide

The grill-heating elements are located on the ceiling of the cooking chamber. These elements operate only when the door is closed and the turntable is rotating.

When grilling food, put the food on the high rack unless otherwise instructed.

Preheat the grill for 3 minutes with Grill mode, and, unless otherwise instructed below, grill food on the high rack. When grilling is complete, use oven gloves to take out the food.

Cookware

Grill: Use flameproof containers, which may include metal parts. Do not use plastic cookware of any kind.

Microwave+Grill: Do not use cookware that is made of metal or plastic substances.

Food type

Chops, sausages, steaks, hamburgers, bacon and gammon rashers, thin fish portions, sandwiches, and all kinds of toast with toppings.

Grilling

Food	Amount	Mode	Cooking time	
			1 st side (min.)	2 nd side (min.)
Toast Slices	4 pcs (each 25 g)	Grill only	5 ½ - 6 ½	-
	Put toast slices side by side on the high rack.			
Grilled Tomatoes	2 pcs (0.9 lb.)	30 % + Grill	7 - 8	-
	Cut tomatoes into halves. Put some cheese on top. Arrange in a circle in a flat glass Pyrex dish. Place it on the high rack. Stand for 2 - 3 minutes.			
Tomato + Cheese Toast	4 pcs (0.7 lb.)	20 % + Grill	5 - 6	-
	Toast the bread slices first. Put the toast with topping on the high rack. Stand for 2 - 3 minutes			
Toast Hawaii	4 pcs (1.1 lbs.)	30 % + Grill	5 - 6	-
	Toast the bread slices first. Put the toast with topping on the high rack. Stand for 2 - 3 minutes.			
Baked Potatoes	1.1 lbs.	50 % + Grill	15 - 17	-
	Cut potatoes into halves. Brush potatoes with oil and parsley. Put them in a circle on the high rack with the cut side to the grill.			
Baked Apples	2 apples	30 % + Grill	6 - 7	-
	Core the apples and fill them with raisins and jam. Put some almond slices on top. Put apples on a flat glass Pyrex dish. Place the dish directly on the low rack.			
Chicken Pieces	1.1 lbs. (2 pcs)	30 % + Grill	12 - 14	9 - 11
	Brush chicken pieces with oil and spices. Put them in a circle on the high rack. After grilling stand for 2 - 3 minutes.			

Food	Amount	Mode	Cooking time	
			1 st side (min.)	2 nd side (min.)
Beef Steaks (Medium)	0.9 lb. (2 pcs)	Grill only	8 - 10	6 - 8
	Brush the beef steaks with oil. Lay them in a circle on the high rack. After grilling stand for 2 - 3 minutes.			
Roast Fish	0.9 - 1.1 lbs.	30 % + Grill	9 - 11	5 - 7
	Brush skin of whole fish with oil and add herbs and spices. Put two fish side by side (head to tail) on the high rack. After grilling stand for 2 - 3 minutes.			

Crusty plate

We recommend you to preheat the crusty plate while it's on the turntable for 3 - 4 minutes.

Food	Amount (lb.)	Preheat		Cooking	
		Mode	Time (min.)	Mode	Time (min.)
Bacon	0.2 (4 - 6 slices)	60 % + Grill	3	60 % + Grill	3 - 4
	Preheat crusty plate. Put slices side by side on crusty plate. Put plate on high rack.				
Potato Wedges	0.6	60 % + Grill	4	50 % + Grill	9 - 11
	Rinse and clean potatoes. Cut into wedges or cubes. Brush with olive oil, herbs and spices. Distribute cubes evenly on plate. Put plate on high rack. Turn over after 5 - 7 minutes.				
Frozen Chicken Nuggets	0.7	60 % + Grill	4	60 % + Grill	6 - 8
	Preheat crusty plate. Brush plate with 1 tbsp. oil. Put chicken nuggets on crusty plate. Put plate on the high rack. Turn over after 4 - 5 minutes.				

Power Convection guide

Cooking with Power Convection is a powerful combination of the inner grill heater and the convection ring heater with fan at side. The hot air blows from the top of the cavity through holes into the oven. The heating element at top and side and the fan at the side-wall, keeps the hot air circulating evenly.

Use this mode for biscuits, individual scones, rolls, and cakes as well as fruit cakes, choux, and soufflés. Before cooking, preheat with guided temperatures.

All conventional ovenproof cookware, baking tins and sheets – anything you would normally use in a traditional convection oven – can be used.

Food	Amount	Temperature (°F)	Cooking time (min.)
Frozen Mini Tartes/ Pizza Snacks	0.6 lb.	400	9 - 12
	Put pizza snacks on the crusty plate. Put plate on low rack.		
Frozen Oven Chips	0.7 lb.	400	14 - 16
	Distribute frozen oven chips on crusty plate. Put plate on high rack.		
Frozen Chicken Nuggets	0.7 lb.	400	7 - 9
	Put frozen nuggets on crusty plate. Put plate on the high rack.		
Frozen Pizza	0.7 lb.	400	11 - 13
	Put frozen Pizza on the low rack.		
Homemade Lasagna/ Pasta Gratin	1.1 lbs.	350	25 - 30
	Put pasta in ovenproof dish. Put dish on low rack.		
Roast Vegetables	0.7 lb.	400	10 - 12
	Rinse and prepare vegetables in slices (e.g. courgette, egg plants, pepper, pumpkin). Brush with olive oil and add spices. Put on crusty plate on high rack.		

Cooking Smart

Convection guide

Convection

In Convection mode, both the heating element and the side-wall fan operate together to circulate the heat inside the cooking chamber. Use this mode for biscuits, individual scones, rolls, and cakes as well as fruit cakes, choux, and soufflés. All conventional ovenproof cookware, baking tins and sheets – anything you would normally use in a traditional convection oven – can be used.

Microwaves+Convection

This combination mode combines the microwave energy with hot air, resulting in reduced cooking time and producing a brown, crispy surface of the food. The oven offers 5 different combination modes for your convenience. Use this for all kinds of meat and poultry as well as casseroles and gratin dishes, sponge cakes and light fruit cakes, pies and crumbles, roast vegetables, scones, and breads. Use only ovenproof cookware, such as glasses, potteries, or bone china without metal trim.

Before cooking, preheat with guided temperatures, and wait until the cycle is complete. Set the power level and cooking time as instructed below. Use oven gloves when taking out food.

Food		Amount	Power		Cooking time	
			1 st Step	2 nd Step	1 st Step (min.)	2 nd Step (min.)
Pizza	Frozen Pizza (Ready Baked)	0.7 - 0.9 lb.	30 % + 400 °F	Conv. 350 °F	9 - 11	4 - 6
		Place the pizza on the low rack. After baking, let stand for 2 - 3 minutes.				
Pasta	Frozen Lasagne	0.9 lb.	30 % + 400 °F	Conv. 400 °F	16 - 18	3 - 4
		Put into a suitable sized glass pyrex dish or leave in the original packaging (take care that this is suitable for microwaves and oven heat). Put frozen pasta gratin on the low rack. After cooking, let stand for 2 - 3 minutes.				

Food		Amount	Power		Cooking time	
			1 st Step	2 nd Step	1 st Step (min.)	2 nd Step (min.)
Meat	Roast Beef/ Lamb (Medium)	2.7 - 2.9 lbs.	30 % + 350 °F		22 - 25	14 - 16
		Brush beef/lamb with oil and spice it with pepper, salt and paprika. Put it on the low rack, first with the fat side down. After cooking, wrap in aluminium foil and let stand for 10 - 15 minutes.				
Meat	Roast Chicken	2.6 - 2.8 lbs.	30 % + 400 °F	30 % + 400 °F	24 - 26	23 - 25
		Brush chicken with oil and spices. For the first step, put the chicken breast side down on the low rack. For the second step, turn the chicken breast side up. Let stand for 5 minutes.				
Bread	Frozen Bread Rolls	0.8 lb. (6 pcs)	30 % + 350 °F		7 - 9	-
		Put bread rolls in a circle on the crusty plate, then on the low rack. Let stand for 2 - 3 minutes.				
	Garlic Bread (Chilled, Prebaked)	0.45 lb. (1 pc)	30 % + 400 °F		7 - 9	-
Put the chilled baguette on baking paper on the low rack. After baking, let stand for 2 - 3 minutes.						
Cake	Marble Cake (Fresh Dough)	1.1 lbs.	Only 350 °F		38 - 43	-
		Put the fresh dough in a small rectangular black metal baking dish (length 25 cm). Put the cake on the low rack. After baking, let stand for 5 - 10 minutes.				
	Small Cakes (Fresh Dough)	12 x 0.06 lb.	Only 325 °F		25 - 28	-
Fill the fresh dough evenly in paper cups and set on crusty plate on the low rack. After baking, let stand for 5 minutes.						
Cookies (Fresh Dough)	Cookies (Fresh Dough)	0.45 - 0.6 lb.	Only 400 °F		13 - 17	-
		Put the chilled croissants on baking paper on the low rack.				

Quick & Easy

Melting butter

Put about 3 tbsp. butter into a small deep glass dish. Cover with plastic lid. Heat for 30 - 40 seconds using 90 %, until butter is melted.

Melting chocolate

Put about a half cup (¼ lb.) chocolate into a small deep glass dish. Heat for 3 - 5 minutes, using 50 % until chocolate is melted. Stir once or twice during melting. Use oven gloves while taking out!

Melting crystallized honey

Put ¾ oz. (20 g) crystallized honey into a small deep glass dish. Heat for 20 - 30 seconds using 30 %, until honey is melted.

Melting gelatine

Lay dry gelatine sheets ⅓ oz. (10 g) for 5 minutes in cold water. Put drained gelatine into a small glass Pyrex bowl. Heat for 1 minute using 30 %. Stir after melting.

Cooking glaze/icing (for cake and gateaux)

Mix instant glaze (approximately 3 tbsp.) with 2 ⅔ tbsp. (40 g) sugar and 1 cup (250 ml) cold water. Cook uncovered in a glass Pyrex bowl for 3 ½ to 4 ½ minutes using 90 %, until glaze/icing is transparent. Stir twice during cooking.

Cooking jam

Put 21 oz. of fruit (600 g or about 2 ½ cups) (for example mixed berries) in a suitable sized glass Pyrex bowl with lid. Add 1 ½ cups (300 g) preserving sugar and stir well. Cook covered for 10 - 12 minutes using 90 %. Stir several times during cooking. Empty directly into small jam glasses with twist-off lids. Let stand with the lid on for 5 minutes.

Cooking pudding

Mix the pudding mix with milk following the manufacturer's instructions. Add sugar if instructed. Stir well. Use a suitable sized glass Pyrex bowl with lid. Cook covered for 6 ½ to 7 ½ minutes using 90 %. Stir several times well during cooking.

Browning almond slices

Spread about 1 oz. (30 g) of sliced almonds evenly on a medium sized ceramic plate. Stir several times during browning for 3 ½ to 4 ½ minutes using 60 %. Let it stand for 2 - 3 minutes in the oven. Use oven gloves when taking out!

Troubleshooting

If you encounter a problem using your microwave, first check the table below and try the recommendations. If a problem persists, or if an information code keeps appearing on the display, contact a local Samsung service center.

Checkpoints

Problem	Cause	Action
General		
The buttons cannot be touched properly.	Foreign matter may be caught between the buttons.	Remove the foreign matter and try again.
	For touch models: Moisture is on the exterior.	Wipe the moisture from the exterior.
	Control lock is activated.	Deactivate Control lock.
The time is not displayed.	The Screen Saver is set.	Turn off the Screen Saver.
The oven does not work.	Power is not supplied.	Make sure power is supplied.
	The door is open.	Close the door and try again.
	The door open safety mechanisms are covered in foreign matter.	Remove the foreign matter and try again.
The oven stops while in operation.	The user has opened the door to turn food over.	After turning over the food, touch the Start button again to start operation.

Problem	Cause	Action
The power turns off during operation.	The oven has been cooking for an extended period of time.	After cooking for an extended period of time, let the oven cool.
	The cooling fan is not working.	Listen for the sound of the cooling fan.
	Trying to operate the oven without food inside.	Put food in the oven.
	There is not sufficient ventilation space for the oven.	There are intake/exhaust outlets on the front and rear of the oven for ventilation. Keep the gaps specified in the product installation guide.
	Several power plugs are being used in the same socket.	Designate only one socket to be used for the oven.
There is a popping sound during operation, and the oven doesn't work.	Cooking sealed food or using a container with a lid may cause popping sounds.	Do not use sealed containers as they may burst during cooking due to expansion of the contents.
The oven exterior is too hot during operation.	There is not sufficient ventilation space for the oven.	There are intake/exhaust outlets on the front and rear of the oven for ventilation. Keep the gaps specified in the product installation guide.
	Objects are on top of the oven.	Remove all objects on the top of the oven.
The door cannot be opened properly.	Food residue is stuck between the door and oven interior.	Clean the oven and then open the door.

Problem	Cause	Action
Heating including the Warm function does not work properly.	The oven may not work, too much food is being cooked, or improper cookware is being used.	Put one cup of water in a microwave-safe container and run the microwave for 1 - 2 minutes to check whether the water is heated. Reduce the amount of food and start the function again. Use a cooking container with a flat bottom.
The thaw function does not work.	Too much food is being cooked.	Reduce the amount of food and start the function again.
The interior light is dim or does not turn on.	The door has been left open for a long time.	The interior light may automatically turn off when the Eco function operates. Close and reopen the door or touch the ↶ button or press the Dial.
	The interior light is covered by foreign matter.	Clean the inside of the oven and check again.
A beeping sound occurs during cooking.	If the Auto Cook function is being used, this beeping sound means it's time to turn over the food during thawing.	After turning over the food, touch the Start button again to restart operation.
The oven is not level.	The oven is installed on an uneven surface.	Make sure the oven is installed on flat, stable surface.
There are sparks during cooking.	Metal containers are used during the oven/thawing functions.	Do not use metal containers.
When power is connected, the oven immediately starts to work.	The door is not properly closed.	Close the door and check again.

Problem	Cause	Action
There is electricity coming from the oven.	The power or power socket is not properly grounded.	Make sure the power and power socket are properly grounded.
1. Water drips. 2. Steam emits through a door crack. 3. Water remains in the oven.	There may be water or steam in some cases depending on the food. This is not an oven malfunction.	Let the oven cool and then wipe with a dry dish towel.
The brightness inside the oven varies.	Brightness changes depending on power output changes according to function.	Power output changes during cooking are not malfunctions. This is not an oven malfunction.
Cooking is finished, but the cooling fan is still running.	To ventilate the oven, the cooling fan continues to run for about 3 minutes after cooking is complete.	This is not an oven malfunction.
Turntable		
While turning, the turntable comes out of place or stops turning.	There is no roller ring, or the roller ring is not properly in place.	Install the roller ring and then try again.
The turn table drags while turning.	The roller ring is not properly in place, there is too much food, or the container is too large and touches the inside of the microwave.	Adjust the amount of food and do not use containers that are too large.
The turn table rattles while turning and is noisy.	Food residue is stuck to the bottom of the oven.	Remove any food residue stuck to the bottom of the oven.

Troubleshooting

Problem	Cause	Action
Grill		
Smoke comes out during operation.	During initial operation, smoke may come from the heating elements when you first use the oven.	This is not a malfunction, and if you run the oven 2 - 3 times, it should stop.
	Food is on the heating elements.	Let the oven cool and then remove the food from the heating elements.
	Food is too close to the grill.	Put the food a suitable distance away while cooking.
	Food is not properly prepared and/or arranged.	Make sure food is properly prepared and arranged.
Oven		
The oven does not heat.	The door is open.	Close the door and try again.
Smoke comes out during preheating.	During initial operation, smoke may come from the heating elements when you first use the oven.	This is not a malfunction, and if you run the oven 2 - 3 times, it should stop.
	Food is on the heating elements.	Let the oven cool and then remove the food from the heating elements.
There is a burning or plastic smell when using the oven.	Plastic or non heat-resistant cookware is used.	Use glass cookware suitable for high temperatures.

Problem	Cause	Action
There is a bad smell coming from inside the oven.	Food residue or plastic has melted and stuck to the interior.	Use the steam function and then wipe with a dry cloth. You can put a lemon slice inside and run the oven to remove the odour more quickly.
The oven does not cook properly.	The oven door is frequently opened during cooking.	If you open the door often, the interior temperature will be lowered and this may affect the results of your cooking.
	The oven controls are not correctly set.	Correctly set the oven controls and try again.
	The grill or other accessories are not correctly inserted.	Correctly insert the accessories.
	The wrong type or size of cookware is used.	Use suitable cookware with flat bottoms.

Information codes

If the oven fails to operate, you may see an information code on the display. Check the table below and try the suggestions.

Code	Description	Action
C-20	The temperature sensor is open.	Unplug the power cord of the oven, and contact a local Samsung service center.
	The temperature sensor is shorted.	
C-A1	The oven has failed to sense the opening or closing of the damper for 1 minute.	
C-F0	The microwave has sensed an internal communications failure.	
C-21	Temperature sensor has detected a temperature that exceeds the allowable temperature for an operation.	Turn off the microwave oven, unplug it, and let it cool, then try the setting again. If this code re-appears, call your local Samsung service center.
C-F2	The touch key malfunction.	Touch Stop or press the Dial to try again.
C-d0		Turn off the microwave oven, unplug it, and let it cool. Clean the button and area around the button. If this code re-appears, call your local Samsung service center.
C-d1	When door lock motor cannot find its position.	Check door lock operation when re-applying power. If this code appears again, call your local Samsung service center.

Technical specifications

Samsung strives to improve its products at all times. Both the design specifications and the user instructions are thus subject to change without notice.

Power Source		120 V ~ 60 Hz
Power Consumption	Maximum Power	1650 W
	Microwave	1600 W
	Grill	1600 W
	Convection	1650 W
	Power Convection	1650 W
Output Power		100 W / 900 W (IEC - 705)
Operating Frequency		2450 MHz
Cooling Method		Cooling fan motor
Dimensions (W x H x D)	Main Unit (Include Handle)	20 ¹³ / ₁₆ X 15 ¹⁵ / ₁₆ X 18 ¹⁵ / ₁₆ (in)
	Cooking Chamber	15 ³ / ₄ X 8 ⁵ / ₈ X 15 ⁵ / ₈ (in)
Volume		1.2 cu.ft
Weight	Net	Approx. 61.95 lb. (28.1 kg)

Warranty

Samsung MICROWAVE OVEN

LIMITED WARRANTY TO ORIGINAL PURCHASER WITH PROOF OF PURCHASE

This Samsung brand product, as supplied and distributed by Samsung ELECTRONICS AMERICA, INC. (Samsung) and delivered new, in the original carton to the original consumer purchaser, is warranted by Samsung against manufacturing defects in materials or workmanship for the limited warranty period, starting on the date of delivery to the original consumer purchaser, of:

One (1) Year Parts and Labor

Ten (10) Years Magnetron Part (Part Only)

This limited warranty is valid only on products purchased and used in the United States that have been installed, operated, and maintained according to the instructions attached to or furnished with the product. To receive warranty service, the purchaser must contact Samsung at the address or phone number provided below for problem determination and service procedures. Warranty service can only be performed by a Samsung authorized service center. The original dated bill of sale and/or proof of delivery must be presented upon request as proof of purchase to Samsung or Samsung's authorized service center to receive warranty service.

Samsung will provide in-home service within the contiguous United States during the warranty period at no charge, subject to availability of Samsung authorized servicers within the customer's geographic area. If in-home service is not available, Samsung may elect, at its option, to provide transportation of the product to and from an authorized service center. If the product is located in an area where service by a Samsung authorized servicer is not available, you may be responsible for a trip charge or required to bring the product to a Samsung authorized service center for service.

To receive in-home service, product must be unobstructed and accessible to the service agent.

During the applicable warranty period, a product will be repaired, replaced, or the purchase price refunded, at the sole option of Samsung. Samsung may use new or reconditioned parts in repairing a product, or replace the product with a new or reconditioned product. Replacement parts and products are warranted for the remaining portion of the original product's warranty or ninety (90) days, whichever is longer.

All replaced parts and products are the property of Samsung and you must return them to Samsung.

This limited warranty covers manufacturing defects in materials or workmanship encountered in normal household, noncommercial use of this product and shall not cover the following: damage that occurs in shipment, delivery, installation, and uses for which this product was not intended; damage caused by unauthorized modification or alteration of the product; product where the original factory serial numbers have been removed, defaced, changed in any way, or cannot be readily determined; cosmetic damage including scratches, dents, chips, and other damage to the product's finishes; damage caused by abuse, misuse, overheating due to overcooking, glass tray or turntable, pest infestations, accident, fire, floods, or other acts of nature or God; damage caused by use of equipment, utilities, services, parts, supplies, accessories, applications, installations, repairs, external wiring or connectors not supplied or authorized by Samsung; damage caused by incorrect electrical line current, voltage, fluctuations and surges; damage caused by failure to operate and maintain the product according to instructions; in-home instruction on how to use your product; service to correct installation not in accordance with electrical or plumbing codes or correction of household electrical or plumbing (i.e., house wiring, fuses, or water inlet hoses); and reduced magnetron power output related to normal aging. The cost of repair or replacement under these excluded circumstances shall be the customer's responsibility.

Visits by an authorized servicer to explain product functions, maintenance or installation are not covered by this limited warranty. Please contact Samsung at the number below for assistance with any of these issues.

Samsung will charge a repair fee for replacing an accessory or repairing cosmetic damage if the damage to the unit and/or damage to or loss of the accessory was caused by the customer. Items this covers include:

- Dented, scratched, or broken door, handle, out-panel, or control panel
- Broken or lost tray, guide roller, coupler, filter, or wire rack

Parts that Samsung has determined can be replaced by the user may be sent to the customer for installation. In Samsung's discretion, an authorized servicer can be dispatched to perform such installation.

EXCLUSION OF IMPLIED WARRANTIES

IMPLIED WARRANTIES, INCLUDING THE IMPLIED WARRANTIES OF MERCHANTABILITY OR FITNESS FOR A PARTICULAR PURPOSE, ARE LIMITED TO ONE YEAR OR THE SHORTEST PERIOD ALLOWED BY LAW. Some states do not allow limitations on how long an implied warranty lasts, so the above limitations or exclusions may not apply to you. This warranty gives you specific rights, and you may also have other rights, which vary from state to state.

LIMITATION OF REMEDIES

YOUR SOLE AND EXCLUSIVE REMEDY IS PRODUCT REPAIR, PRODUCT REPLACEMENT, OR REFUND OF THE PURCHASE PRICE AT Samsung's OPTION, AS PROVIDED IN THIS LIMITED WARRANTY. Samsung SHALL NOT BE LIABLE FOR SPECIAL, INCIDENTAL OR CONSEQUENTIAL DAMAGES, INCLUDING BUT NOT LIMITED TO TIME WAY FROM WORK, HOTELS AND/OR RESTAURANT MEALS, REMODELING EXPENSES, LOSS OF REVENUE OR PROFITS, FAILURE TO REALIZE SAVINGS OR OTHER BENEFITS REGARDLESS OF THE LEGAL THEORY ON WHICH THE CLAIM IS BASED, AND EVEN IF Samsung HAS BEEN ADVISED OF THE POSSIBILITY OF SUCH DAMAGES. Some states do not allow exclusion or limitation of incidental or consequential damages, so the above limitations or exclusions may not apply to you. This warranty gives you specific rights, and you may also have other rights, which vary from state to state.

Samsung does not warrant uninterrupted or error-free operation of the product.

No warranty or guarantee given by any other person, firm, or corporation with respect to this product shall be binding on Samsung.

To obtain warranty service, please contact Samsung at:

Samsung Electronics America, Inc.

85 Challenger Road

Ridgefield Park, NJ 07660

1-800-SAMSUNG (726-7864) and www.samsung.com/us/support



Scan the QR code* or visit
www.samsung.com/spsn
to view our helpful
How-to Videos and Live Shows

*Requires reader to be installed on your
smartphone

Scan this with your smart phone

Please be advised that the Samsung warranty does NOT cover service calls to explain product operation, correct improper installation, or perform normal cleaning or maintenance.

QUESTIONS OR COMMENTS?

COUNTRY	CALL	OR VISIT US ONLINE AT
U.S.A Consumer Electronics	1-800-SAMSUNG (726-7864)	www.samsung.com/us/support
CANADA	1-800-SAMSUNG (726-7864)	www.samsung.com/ca/support (English) www.samsung.com/ca_fr/support (French)

