

ZLINE

ATTAINABLE LUXURY[®]

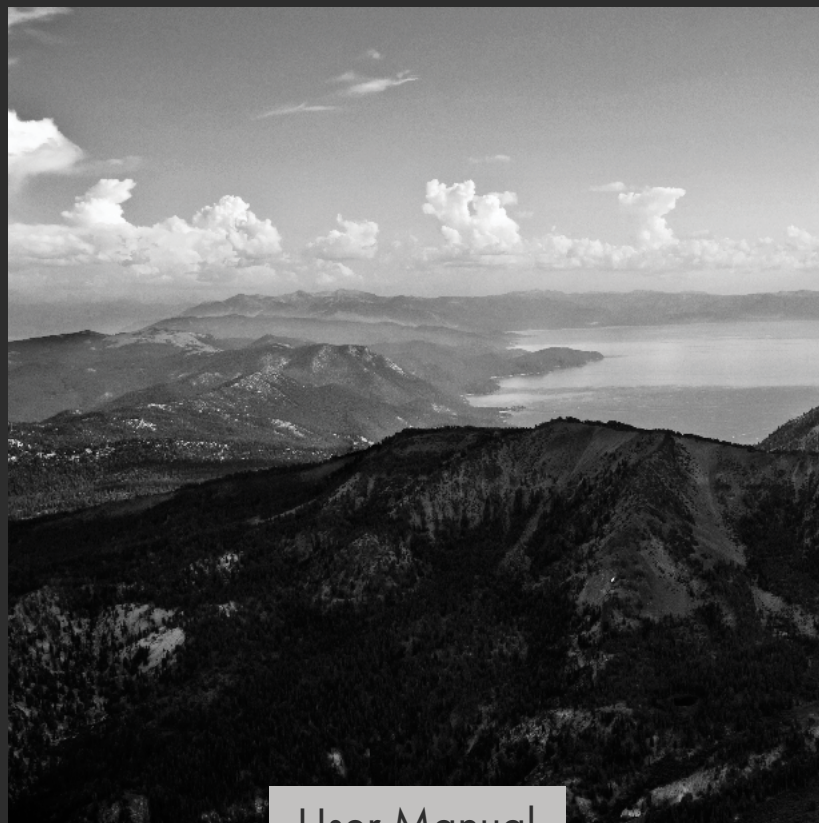

User Manual

OVER THE RANGE MICROWAVE OVEN MWO-OTR-30 SERIES

www.zlinekitchen.com



ZLINE Kitchen and Bath provides Attainable Luxury, where the kitchen and bath of your dreams is never out of reach. Through our unique designs and unparalleled quality, we're dedicated to providing you an elevated experience in the heart of your home. With an endless selection of features and finishes, our inspiration is your reality.

ZLINE
ATTAINABLE LUXURY®



ZLINE is fueled by a passion for innovation; A relentless pursuit of bringing the highest end luxury designs and professional features into everyone's homes.

Because we continually strive to improve our products, we may change specifications and designs without prior notice.

Scan the QR code to view the most up-to-date version of the Installation Manual and User Manual.

⚠ WARNING: This product can expose you to chemicals including nickel, which is known to the State of California to cause cancer. For more information, go to www.P65Warnings.ca.gov.

TABLE OF CONTENTS

IMPORTANT SAFETY INSTRUCTIONS	1
OPERATION	7
CARE AND CLEANING	25
TROUBLESHOOTING.....	27
WARRANTY.....	28

IMPORTANT SAFETY INSTRUCTIONS



Before operation, please read and follow these important instructions for the safety of your home and the people living in it.

- When using electrical appliances, basic safety precautions should be followed, including the following:
- Install or locate this appliance only in accordance with the provided installation instructions.
- This appliance is intended to be used in households and similar applications such as: staff kitchen areas in shops, offices, and other working environments; by clients in hotels, motels, and other residential type environments; farm houses; and bed and breakfast type environments.
- Do not attempt to operate this oven with the door open. This can result in harmful exposure to microwave energy.
- Do not break or tamper with the safety interlocks.
- Do not place any object between the oven front face and the door or allow soil or cleaning residue to accumulate on sealing surfaces.
- Do not operate the oven if it is damaged. It is particularly important that the oven door closes properly and that there is no damage to the:
 - Door (bent or broken)
 - Hinges and latches (broken or loosened)
 - Door seals and sealing surfaces (dirty or eroding)
- The oven should not be adjusted or repaired by anyone except properly qualified service personnel.
- If the oven is not maintained in a good state of cleanliness, its surface could be degraded and affect the lifespan of the oven and lead to a dangerous situation.

IMPORTANT SAFETY INSTRUCTIONS

- Use this appliance only for its intended use as described in the manual. Do not use corrosive chemicals or vapors in this appliance
- This type of oven is designed to heat, cook, or defrost food. It is not designed for industrial or laboratory use.
- Do not use harsh abrasive cleaners or sharp metal scrapers to clean the oven door glass since they can scratch the surface, which may result in shattering.
- Heavily soiled seal: If the seal is very dirty or eroded, the appliance door will no longer close properly during operation. The fronts of adjacent units could also be damaged. Always keep the seal clean.
- This appliance can be used by children if they have been given supervision or instruction on use of the appliance in a safe way and understand the hazards involved.
- Children shall not play with the appliance. Cleaning and user maintenance shall not be made by children without supervision. Keep the appliance and its cord out of reach of children without supervision.
- If the electrical cord is damaged, it must be replaced by the manufacturer or a similarly qualified professional in order to avoid a hazard.
- Do not immerse cord or plug in water.
- Keep cord away from heated surface.
- Do not let cord hang over edge of table or counter.
- Do not cover or block any openings on the appliance.
- Do not store this appliance outdoors. Do not use near water – for example, near a kitchen sink, in a wet basement, near a swimming pool, or similar location.

IMPORTANT SAFETY INSTRUCTIONS

- To reduce the risk of fire inside the oven:
 - Do not overcook food. Carefully oversee appliance when paper, plastic, or other combustible materials are placed inside the oven to facilitate cooking.
 - Remove wire twist-ties from paper or plastic bags before placing bags in oven.
- If material inside the oven ignites, keep oven door closed, turn oven off, and disconnect power cord or shut off power at the circuit breaker.
 - Do not use the microwave for storage purposes.
 - Do not leave paper products, cooking utensils, or food inside when not in use.
- If smoke is emitted, switch off and unplug the appliance and keep the door closed in order to stifle any flames.
- Care should be taken not to displace the turntable when removing containers from the appliance.
- Some products, such as whole eggs and sealed containers — for example, closed glass jars — can explode and should not be heated in this oven.
- **HOT CONTENTS CAN CAUSE SEVERE BURNS. DO NOT ALLOW CHILDREN TO USE THE MICROWAVE.** Use caution when removing hot items.

IMPORTANT SAFETY INSTRUCTIONS



Liquids and other foods must not be heated in sealed containers since they are liable to explode.

- Liquids such as water, coffee, or tea may be heated beyond the boiling point without appearing to be boiling. Visible bubbling or boiling when the container is removed from the microwave oven is not always present. THIS COULD RESULT IN VERY HOT LIQUID SUDDENLY BOILING OVER WHEN THE CONTAINER IS DISTURBED OR A UTENSIL IS INSERTED INTO THE LIQUID. To reduce the risk of injury to persons:
 - Do not overheat the liquid.
 - Stir the liquid both before and halfway through heating it.
 - Do not use straight-sided containers with narrow necks.
 - After heating, allow the container to stand in the microwave oven for a short time before removing the container.
 - Use extreme care when inserting a spoon or other utensil into the container.
- Do not store anything directly on top of the appliance surface when the appliance is in operation.
- Oversized food or oversized metal utensils should not be inserted in the oven as they may create a fire or risk of electric shock.
- The appliance shall not be cleaned with a steam cleaner.
- Do not clean with metal scouring pads. Pieces can burn off the pad and touch electrical parts, increasing the risk of electric shock.
- Do not store any materials, other than manufacturer's recommended accessories, in this oven when not in use.
- Do not cover racks or any part of the oven with metal foil.

IMPORTANT SAFETY INSTRUCTIONS

- When heating food in plastic or paper containers, keep an eye on the oven due to the possibility of ignition.
- Only use utensils suitable for use in microwave ovens.
- The contents of feeding bottles and baby food jars must be stirred or shaken and the temperature checked before consumption in order to avoid burns.
- The oven should be cleaned regularly and any food deposits removed since they may explode even after microwave heating has ended.
- The microwave oven is intended for heating food and beverages. Drying of food or clothing and heating of warming pads, slippers, sponges, damp cloths, and similar items may lead to risk of injury, ignition, or fire.



The appliance and accessible parts become hot during use. Care should be taken to avoid touching heating elements. Metallic containers for food and beverages are not allowed during microwave cooking.

- The appliance is intended to be used built-in.
- The appliance must not be installed behind a decorative door in order to avoid overheating.
- Using metal, aluminum, or other non-microwave-safe objects in the microwave function can cause sparks. Sparks can irreparably damage the glass on the inside the of the door.
- Never pour water inside the oven. This will cause steam. The temperature change can cause damage.
- Do not store moist food in the oven for long periods.
- Do not use the appliance to store food. This can lead to corrosion.

IMPORTANT SAFETY INSTRUCTIONS

- Do not trap anything in the appliance door. Even if the door is only slightly ajar, the fronts of adjacent units may be damaged over time.
- Do not operate the microwave without food inside. Doing so may lead to power overloading. Never switch on the appliance unless there is food in the cooking compartment.
- When using the convection bake/roast or convection + micro features, the plastic coupler and turntable ring inside the unit do NOT need to be removed; neither will be impacted by these forms of cooking.
- Do not operate any heating or cooking appliance beneath, over, or near the appliance. It is okay to use the microwave above another heating appliance.
- This appliance is suitable for use above both gas and electric cooking equipment.
- Do not mount over any sinks.
- Do not store anything directly on top of the appliance surface when the appliance is in operation.
- Clean ventilation hoods frequently. Grease should not be allowed to accumulate on the hood or filters.
- Use care when cleaning the vent-hood filter. Corrosive cleaning agents may damage the filter.

OPERATION

RADIO INTERFERENCE

- Operation of the microwave oven may cause interference to your radio, TV, or similar equipment.
- When there is interference, it may be reduced or eliminated by taking the following measures:
 - Clean the door and sealing surface of the oven.
 - Reorient the receiving antenna of the radio or TV.
 - Move the microwave oven away from the receiver.
 - Plug the microwave oven into a different outlet so the appliance and receiver are on different branch circuits.

UTENSILS FOR USE IN MICROWAVE MODE



PERSONAL INJURY HAZARD

- Tightly-closed utensils could explode. Closed containers should be opened and plastic pouches should be pierced before cooking.
- Carefully review the instructions on page 8 regarding what utensils to NOT use while using the microwave function.
- Please note there may be certain non-metallic utensils that are not safe to use for microwaving. If in doubt, you can test the utensil in question following the procedure below.

UTENSIL TEST

Fill a microwave-safe container with 1 cup of cold water along with the utensil in question.

1. Cook on maximum microwave cooking power for 1 minute.
2. Carefully feel the utensil. If the utensil is warm, do not use it for microwave cooking.
3. Do not exceed 1 minute cooking time.

OPERATION

MATERIALS YOU CAN USE IN MICROWAVE OVEN	
Utensils	Remarks
Browning dish	Follow manufacturer's instructions. The bottom of the dish must be at least 3/16" above the turntable. Incorrect usage may cause the turntable to break.
Dinnerware	Microwave-safe only. Follow manufacturer's instructions. Do not use cracked or chipped dishes.
Glass jars	Always remove lid. Use only to heat food until just warm. Most glass jars are not heat resistant and may break.
Glassware	Use heat-resistant oven glassware only. Make sure there is no metallic trim. Do not use cracked or chipped dishes.
Oven cooking bags	Follow manufacturer's instructions. Do not close with metal twist-tie. Make slits to allow steam to escape.
Paper plates and cups	Use for short term cooking or warming only. Do not leave oven unattended while cooking.
Paper towels	Use to cover food for reheating and absorbing fat. Use with supervision for a short-term cooking only.
Plastic	Microwave-safe only. Follow the manufacturer's instructions. Should be labeled "Microwave Safe." Some plastic containers soften as the food inside gets hot. "Boiling bags" and tightly closed plastic bags should be slit, pierced, or vented as directed by package. Microwave-safe only. Use to cover food during cooking.
Plastic wrap	Microwave-safe only. Use to cover food during cooking to retain moisture. Do not allow plastic wrap to touch food.
Thermometers	Microwave-safe only (meat and candy thermometers).
Wax paper	Use as a cover to prevent splattering and retain moisture.

MATERIALS TO BE AVOIDED IN MICROWAVE OVEN	
Utensils	Remarks
Aluminum tray	Use of metal or aluminum while microwave cooking may cause arcing (sparks inside the unit). Transfer food into microwave-safe dish.
Food carton with metal handle	
Metal or metal-trimmed utensils	Metal shields the food from microwave energy. Metal trim may cause arcing.
Metal twist-ties	May cause arcing and could cause a fire in the oven.
Paper bags	May cause a fire in the oven.
Plastic foam	Plastic foam may melt or contaminate the liquid/food inside when exposed to high temperature.
Wood	Wood will dry out when used in the microwave oven and may split or crack.

OPERATION

Remove the oven and all materials from the carton and oven cavity. Your oven comes with the following parts, features, and accessories:

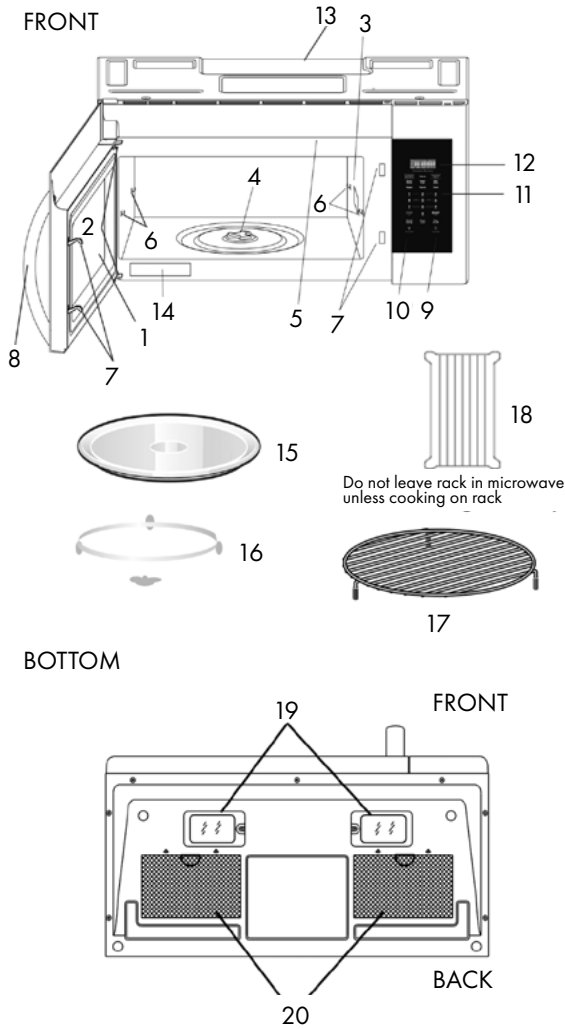

1. Microwave oven door
2. Door hinges
3. Waveguide cover (DO NOT REMOVE)
4. Turntable motor shaft
5. Microwave oven light
6. Rack holders
7. Safety door latches
8. Handle
9. Light button
10. Vent button
11. Control panel
12. Display panel
13. Ventilation
14. Menu label
15. Removable turntable plate
16. Removable turntable support
17. Removable convection wire rack
18. Removable metal rack
19. Light cover/filter access door
20. Grease filters

OPERATION

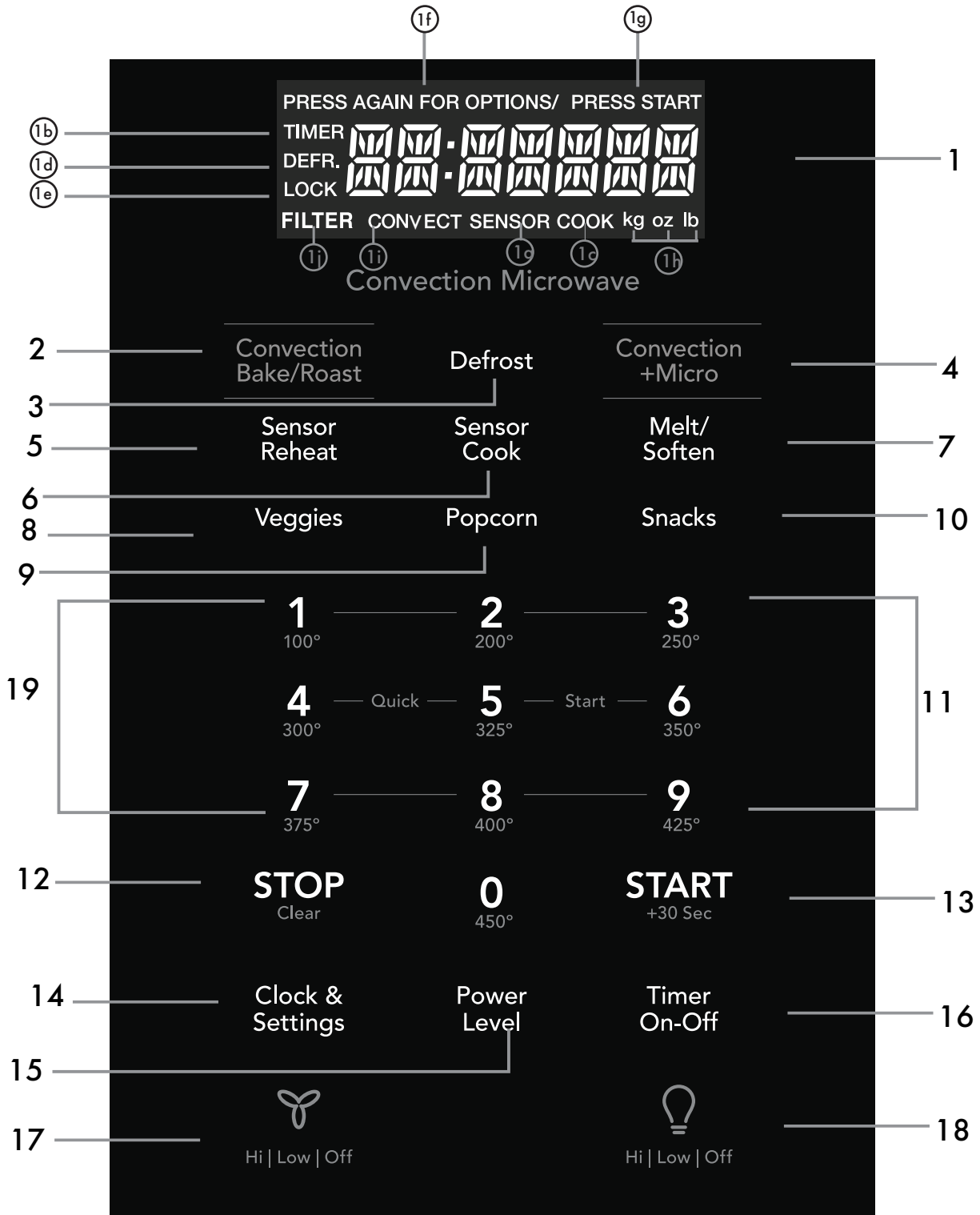

OPERATION

1. Display - features as a clock and indicator that show time, cooking time settings, cook power, sensor, quantities, weights, and cooking functions:
 - 1a. **SENSOR** - when using sensor cook
 - 1b. **TIMER** - when timer is being set or running
 - 1c. **COOK** - starting microwave cooking
 - 1d. **DEFR** - defrosting food
 - 1e. **LOCK** - control lock
 - 1f. **PRESS AGAIN FOR OPTIONS** - additional options are available
 - 1g. **PRESS START** - before a valid function
 - 1h. **KG, OZ, LB** - when choosing weight
 - 1i. **CONVECT** - when choosing convection
 - 1j. **FILTER** - replace charcoal filter
2. Convection Bake/Roast
3. Defrost
4. Convection + Micro
5. Sensor Reheat (4 settings)
6. Sensor Cook
7. Melt/Soften
8. Veggies
9. Popcorn
10. Snacks
11. Numerical Pads
12. Stop/Clear
13. Start (+30 seconds)
14. Clock & Settings
15. Power Level (11 power levels)
16. Timer (On-Off)
17. Vent (High/Low/Off) - use to turn the vent fan off or to adjust speed
18. Surface Light - press to activate and adjust brightness of lights
19. Quick Start (9 instant key settings for cooking by minute)

OPERATION

ONE TOUCH COOKING

POPCORN

The microwave oven lets you pop 3.3, 3.0, 1.75 oz bags of commercially packaged microwave popcorn. Pop only one package at a time. If you are using a microwave popcorn popper, follow manufacturer's instructions:

1. Touch POPCORN.
2. Press again for options
3. Press START

VEGETABLES

The microwave can cook potatoes, frozen vegetables, and fresh vegetables:

1. Touch VEGGIES
2. Press again for options (details in the chart below)
3. Press START

FOOD	AMOUNT	PROCEDURE
Potato	1-4 pieces	Cooking times are based on an average 8 oz. potato. Pierce with forks in several places. Place on paper towel on turntable. Press the VEGGIES pad one time for potato. After cooking, remove from oven and let stand for 5 minutes before eating.
Fresh Vegetables Broccoli Brussels Sprouts Cabbage Cauliflower Spinach Zucchini	2 cups	Wash and place in a microwave-safe casserole dish. Don't add water if the vegetables have been washed. Cover with lid for tender vegetables. Use plastic wrap for tender-crisp vegetables. Press VEGGIES twice. After cooking, stir and then let stand for 2-5 minutes before eating.
Fresh Vegetables Carrots Corn on cob Green beans Winter Squash		Place in microwave-safe casserole dish. Add 1-4 tbsp. water. Cover with lid for tender vegetables. Use plastic wrap cover for tender-crisp vegetables. Press VEGGIES twice for fresh vegetables. After cooking, stir, and then let stand, covered, for 2-5 minutes before eating.
Frozen Vegetables		Don't add water if the vegetables have been washed. Press VEGGIES three times. After cooking, stir and let stand, covered, for 3 minutes before eating.

OPERATION

ONE TOUCH COOKING

SNACK

The Snacks option is for cooking/heating foods for a short amount of time:

1. Touch SNACKS
2. Press again to cycle through the menu.
 - CHOCOLATE CHIP COOKIES
 - FROZEN MW PIZZA
 - HOT DOGS
 - FROZEN KID'S MEAL
 - MEAL IN A CUP
 - SOUP
3. Press START
4. Press the numerical pad to choose the portions
5. Press START

MELT/SOFTEN

The oven uses lower power to melt and soften items:

1. Touch MELT/SOFTEN.
2. Press again to cycle through the menu:
 - BUTTER
 - CHOCOLATE
 - ICE CREAM
 - CREAM CHEESE
3. Press START
4. Press the number keys to set the weight
5. Press START

OPERATION

CONVECTION COOKING

There are 10 temperature options for convection cooking:

1. 100 °F
2. 200 °F
3. 250 °F
4. 300 °F
5. 325 °F
6. 350 °F
7. 375 °F
8. 400 °F
9. 425 °F
10. 450 °F

- Convection cooking uses a heating element to raise the temperature inside the oven. A fan gently circulates this heated air throughout the oven, over and around the food.
- Because the heated air is kept constantly moving, and thus not permitting a layer of cooler air to develop around the food, some foods cook faster than during regular microwave oven cooking.
- For best results, always use the round wire rack when convection cooking. Reduce package/recipe temperature by 25 °F for baked goods. The round wire rack is required for good air circulation and even browning.

USING CONVECTION WITH PREHEATING

1. Press Convection Bake/Roast once (PREHEAT ENTER TEMP)
2. Press the number on the keypad on the desired temperature (see above number chart for temperatures, example: for 375 °F, press 7)
3. Press START and the oven will PREHEAT
4. Temperature will show on the display once it's done preheating; open the door when it's done
5. Place the food in the oven and press the number keys to set the cooking time
6. Press START

OPERATION

USING CONVECTION WITHOUT PREHEATING

1. Press Convection Bake/Roast twice (BAKE ROAST ENTER TEMP)
2. Press the number on the keypad on the desired temperature (see previous page number chart for temperatures, example: for 325 °F, press 5)
3. Press START
4. Place the food in the oven and press the number keys to set the cooking time
5. Press START

MICROWAVE + CONVECTION COMBINATION

1. Press Convection + Micro (BAKE 325 °F)
2. Press START
3. Place the food in the oven and press the number keys to set the cooking time
4. Press START

COOKWARE TIPS

- Always use the round wire rack during convection baking.
- Avoid opening the oven door during convection cooking — each time the door is opened, the oven loses heat and this may cause uneven baking.
- Metal pans are recommended for all types of baked products when convection cooking, but especially where browning or crusting is important.
- Dark or dull finish metal pans are best for convection cooking of bread and pies because they absorb heat and produce crisper crusts.
- Shiny aluminum pans are best for convection cooking of cakes, cookies, or muffins.
- Glass and glass ceramic casserole or baking dishes are best suited for egg and cheese recipes when convection cooking.
- For microwave + convection combination cooking, use glass or glass ceramic containers. Be sure not to use items with metal trim, as this may cause arcing (sparking) with the oven wall or oven shelf, which can damage the cookware, the shelf, or the oven and increase risk of fire or injury.
- When using the convection bake/roast or convection + micro features, the plastic coupler and turntable ring inside the unit do NOT need to be removed; neither will be impacted by these forms of cooking.

OPERATION

SENSOR COOKING

Sensor cooking has an electronic controlled sensor that detects the vapor (moisture and humidity) emitted from the food as it heats. The sensor adjusts the cooking times and power level for various foods and quantities automatically.

BEFORE USING SENSOR COOKING

1. Be sure the exterior of the cooking container and the interior of the oven are dry. Wipe off any moisture with a dry cloth or paper towel.
2. The oven works with foods at normal storage temperature. For example, popcorn would be at room temperature.
3. When using more or less food than the quantity listed on food packaging, the food should be cooked following the guidelines in any microwave cookbook.
4. During the first part of SENSOR COOKING, the food name will appear in the display (as noted in the menu options on the following page). Do not open the oven door or press the STOP/CLEAR pad during this part of the cycle as it will interrupt the process.
5. When the sensor detects the vapor emitted from the food, the remainder of cooking time will appear. The door may be opened when remaining cooking time appears in the display. Stir or season food as desired.
6. If the sensor does not detect vapor properly when popping popcorn, the oven will turn off and the correct time of day will display. It will also show an ERROR CODE and the oven will turn off.
7. Check food for temperature after cooking. If additional time is needed, continue to cook manually, and be sure to allow ample time for cooling before eating.

COVERING FOODS

Some foods cook better when covered during sensor cooking. Use:

1. Casserole lid
2. Plastic wrap
3. Wax paper
 - Be careful when removing coverings to allow steam to escape away from you.

OPERATION

SENSOR COOK MENU

1. Touch SENSOR COOK
2. Press again to cycle through the menu:
 - Bacon
 - Frozen Dinner
 - Rice
 - Frozen Breakfast
 - Frozen Pizza
3. Press START

USING SENSOR REHEAT

1. Touch SENSOR REHEAT
2. Press again to cycle through the menu:
 - Beverage
 - Pizza
 - Soup/Sauce
 - Casserole
3. Press START

OPERATION

AUTO DEFROST

The auto defrost feature provides the best defrosting method for frozen foods. The cooking guide outlined below will show you which defrost sequence is recommended for the food you are defrosting.

USING AUTO DEFROST

1. Touch AUTO DEFROST
2. Press again to cycle through the menu:
 - Meat
 - Poultry
 - Fish
3. Press START
4. Press the number keys to set the weight
5. Press START

For added convenience, the AUTO DEFROST includes a built-in beep mechanism that reminds you to check, turn over, separate, or rearrange the food in order to get the best defrost results. Three different defrosting levels are provided: (available is 0.1–6 lb/ 0.05– 2.7 kg)

1. MEAT
2. POULTRY
3. FISH

MANUAL DEFROST

- You can defrost any frozen food, either raw or previously cooked, by using the 30% power level (refer to chart on page 21). For either raw or previously cooked frozen food, the rule of thumb is approximately 4 minutes per pound. For example, defrost 4 minutes for 1 pound of frozen spaghetti sauce.
- Always stop the oven periodically to remove or separate the portions that are defrosted. If food is not defrosted at the end of the estimated defrosting time, program the oven in 1 minute increments on power level 30% until totally defrosted.
- When using plastic containers from the freezer, defrost only long enough to remove from the plastic in order to place in a microwave-safe dish.

OPERATION

DEFROSTING TIPS

- For best results, remove fish, shell fish, meat, and poultry from its original closed paper or plastic package (wrapper). Otherwise, the wrap will hold steam and juice close to the food, which can cause the outer surface of the food to cook.
- Open containers, such as cartons, before placing in the oven.
- For best results, roll your ground meat into a ball before freezing. During the DEFROST cycle, the microwave will signal when its time to turn the meat over. Scrape off any excess frost from the meat and continue defrosting.
- Place food in a shallow container or on a microwave-safe roasting rack to capture the drips.
- The weight to enter is the net weight in pounds and tenths of pounds (the weight of the food minus the container).
- Before starting, make sure to remove any metal twist-ties that often come with frozen food bags and replace with strings or elastic bands.
- Always slit or pierce plastic pouches/packaging.
- Bend plastic pouches of food to ensure even defrosting.
- Always underestimate defrosting time. If defrosted food is still icy in the center, return it to the microwave oven for more defrosting. The length of defrosting time varies according to how solidly the food is frozen.
- The shape of the package affects how quickly food will defrost. Shallow packages will defrost more quickly than a deep block.
- As food begins to defrost, separate the pieces. Separated pieces defrost more easily.
- For better results, let food stand for a few minutes after defrosting.
- Turn over food during defrosting or standing time. Break apart and remove food as required during the process.
- The metal rack allows several foods to be cooked or reheated at one time. However, for the best cooking and reheating, use Turntable ON function and cook with SENSOR COOKING or AUTO COOKING without the rack.
- When the rack is used, set time and power level manually. Allow plenty of space around and between the dishes. Pay close attention to the cooking and reheating progress. Reposition the foods and reverse them from the rack to turntable and/or stir them at least once during any cooking or reheating time.
- After cooking or reheating, stir if possible. Using a lower power level will assist in better cooking and reheating uniformity.

OPERATION

CLOCK & SETTINGS

The microwave oven has settings that allow you to customize the operation for your convenience. Below are functions showing the various settings. Touch the CLOCK & SETTINGS to cycle through the menu:

1. Clock
2. Control Lock
3. Power Save
4. Volume: Low/Medium/High/Off
5. Charcoal Filter Reset/Off
6. Language
7. Weight LB/KG
8. Demo

SETTING THE CLOCK

The clock can be disabled when the microwave is first plugged in and the STOP/CLEAR is selected. To re-enable the clock:

1. Press CLOCK & SETTINGS
2. Enter the time using the number pad
3. Press START

TIME COOKING

1. Press the number on the keypad for the desired time (example: 5 minutes and 30 seconds, press 5, then 3, then 0)
2. Press START

INTERRUPTING COOKING

You can stop the oven during a cycle by opening the door. The oven stops heating and the fan turns off, but the light stays on.

1. To restart cooking, close the door and Touch START
2. If you do not want to continue cooking, open the door and touch STOP

OPERATION

USING ONE TOUCH START

This is a time-saving option that will automatically start cooking 2 seconds after selected. Numeric key 1, 2, 3 ... all the way to 9 ... can be touched for a 1-minute, 2-minute, etc., automatic start cooking feature.

1. Press the number on the keypad for desired time (example: 5 minutes, press 5)
2. Press START

NOTE: "Food" will be displayed if a quick start cooking cycle or +30 sec key is not selected within 5 minutes of placing food in the microwave. You must open then close the door again to clear "Food" from the display.

SETTING TIMED COOKING WITH POWER LEVEL

This feature lets you program a specific cook time and power. For best results, there are 11 power level settings, including HIGH 100% (refer to chart below):

1. Press the number on the keypad for the desired time (example: 5 minutes and 30 seconds, press 5-3-0)
2. Press POWER LEVEL
3. Press START

PRESS POWER LEVEL PAD NUMBER OF TIMES FOR DESIRED POWER	APPROXIMATE PERCENTAGE OF POWER	COMMON WORDS FOR POWER LEVELS
Power Level x 1	100%	High
Power Level x 2	90%	
Power Level x 3	80%	
Power Level x 4	70%	Medium High
Power Level x 5	60%	
Power Level x 6	50%	
Power Level x 7	40%	
Power Level x 8	30%	Med Low/Defrost
Power Level x 9	20%	
Power Level x 10	10%	Low
Power Level x 11	0%	

OPERATION

SETTING TWO-STAGE COOKING

For best results, some recipes call for different power levels during a cook cycle. You can program your oven for two power level stages during the cooking cycle. Suppose you want to set a 2-stage cook cycle. The first stage is a 3-minute cook time at 80% cook power, followed by a 7-minute cook time at 50% cook power:

1. Press the numbers on the keypad to set cook time for the first stage (example: 3 minutes, press 3-0-0)
2. Press POWER LEVEL three times (again, refer to previous page chart)
3. Press the numbers on the keypad to set cook time for the second stage (example: 7 minutes, press 7-0-0)
4. Press POWER LEVEL six times
5. Press START

SETTING CONTROL LOCK

1. Press CLOCK & SETTINGS two times to get to CONTROL LOCK
2. Press START
3. To turn off, touch the CLOCK & SETTINGS and touch START

SETTING POWER SAVE ON/OFF

1. Press CLOCK & SETTINGS three times to get to POWER SAVE OFF
2. Press START to toggle between ON & OFF

TURNING SOUND LOW/MED/HIGH/OFF

Audible signals are available to guide you when setting and using your oven.

- A programming tone will sound each time you touch a pad
- Three tones signal the end of a kitchen timer countdown
- Three tones signal the end of a cooking cycle

1. To adjust, press CLOCK & SETTINGS four times to get to VOLUME ON
2. Keep pressing to cycle through the options: ON, OFF, LOW, MED, HIGH
3. To set, press START

OPERATION

SETTING FILTER RESET/FILTER OFF

Select FILTER RESET to turn off "FILTER" icon and reset to remind in 6 months to replace the charcoal filter; if you want to turn off "FILTER" icon notification and not receive any reminders, select FILTER OFF and press START:

1. Press CLOCK & SETTINGS and cycle through until you get to FILTER RESET
2. Press START to toggle between FILTER RESET/OFF

SETTING LANGUAGE

There are two languages available: ENGLISH and FRENCH

1. Press CLOCK & SETTINGS and cycle through until you get to FRENCH
2. Press START to toggle between ENGLISH and FRANCAIS

SETTING WEIGHT TO LB/KG

There are two weight units available: LB/KG

1. Press CLOCK & SETTINGS and cycle through until you get to LB/KG
2. Press START to toggle between KG to LB

SETTING DEMO MODE ON/OFF

When DEMO mode is on, programming functions will work in a rapid countdown mode with no cooking power

1. Press CLOCK & SETTINGS and cycle through until you get to DEMO OFF
2. Press START to toggle between ON and OFF

SETTING KITCHEN TIMER

The microwave oven can be used as a kitchen timer. Set up from 99 seconds to 99 minutes. The kitchen timer can be used while the microwave oven is running. NOTE: The timer will not stop if the door is open. To cancel the timer, press TIMER ON-OFF

1. Press TIMER ON-OFF
2. Use the number keypad for the time to count down
3. Press TIMER ON-OFF to start counting down

OPERATION

USING VENT FAN

The touch pad also controls the 2-speed vent fan; the vent fan will go from HIGH to LOW to OFF:

1. Press the VENT icon
2. To turn off, cycle through the options until the fan is off

NOTE: If the temperature from the range or cooktop below the oven gets too hot (158 °F), the vent fan will automatically turn on to protect the oven. It may stay on up to an hour to cool the oven. When this occurs, the vent pad will not turn the fan off.

USING SURFACE LIGHT

The touch pad controls the dimmable surface light. The surface light will go from HIGH to LOW to OFF:

3. Press the LIGHT icon
4. To turn off, cycle through the options until the light is off.

GREASE FILTERS

Each unit comes with two grease filters installed on the bottom of the oven. It's recommended to remove the filters and clean them at least once a month depending on cooking habits. Refer to the "Cleaning Guide" on page 26 for details.

CHARCOAL FILTER

- A charcoal filter is factory installed in most ZLINE MWO-OTR models. The filter is made of activated carbon that is specifically designed to remove contaminants and impurities from the air before recirculating back in your home.
- ZLINE recommends replacing the charcoal filter every 6-9 months. Depending on your cooking habits and household, charcoal filters may be replaced more frequently.
- You can purchase replacement filters at www.zlineparts.com by searching for "MWO-CF". Refer to pages 41–42 of the Installation Manual for removal and replacement instructions.

CARE AND CLEANING

CARE & CLEANING

- Do not use any high-pressure cleaners or steam cleaners on this appliance.
- Never clean the oven immediately after switching off, as you risk being burned.
- Microwave energy may escape if the cooking compartment door or the door seal is damaged, which can be a serious health risk. Never use the appliance if the cooking compartment door or the door seal is damaged. If you see damage, contact ZLINE at 1-614-777-5004.
- Slight differences in color on the front of the appliance are caused by the use of different materials, such as glass, plastic, and metal.
- Shadows on the door panel that look like streaks are caused by reflections made by the oven light.
- Unpleasant odors can be removed easily. Add a few drops of lemon juice to a cup of water. Place a wooden spoon into the container to prevent delayed boiling. Heat the water for 1 to 2 minutes at maximum microwave power.
- When cleaning surfaces of the door and oven that come together when closing the door, use only mild, nonabrasive soaps or a kitchen-safe cleaner applied with a sponge or soft cloth.

CLEANING AGENTS

- To ensure that the different surfaces are not damaged by using the wrong cleaning agent, observe the information in the following table. Do not use:
 - Sharp or abrasive cleaning agents
 - Metal or glass scrapers to clean the glass in the appliance door
 - Metal or glass scrapers to clean the door seal
 - Hard scouring pads and sponges
 - Cleaning agents with high concentrations of alcohol
- Wash new sponge cloths thoroughly before use, and allow all surfaces to dry thoroughly before using the appliance again.

CARE AND CLEANING

CLEANING GUIDE	
Appliance front	Hot soapy water: Clean with a dish cloth and dry with a soft cloth. Do not use glass cleaners or metal or glass scrapers for cleaning.
Appliance front with stainless steel	Hot soapy water: Clean with a dish cloth and dry with a soft cloth. Remove flecks of limescale, grease, starch, and albumin (e.g. egg white) immediately. Corrosion can form under such residues. Special stainless steel cleaning agents can be obtained at appliance stores. Do not use glass cleaners or metal or glass scrapers for cleaning.
Cooking compartment	Hot soapy water: Clean with a dish cloth and dry with a soft cloth. Remove flecks of limescale, grease, starch and albumin (e.g. egg white) immediately. Corrosion can form under such residues. Special stainless steel cleaning agents can be obtained at appliance stores. Do not use glass cleaners or metal or glass scrapers for cleaning.
Recess in cooking compartment	Damp cloth: Ensure that no water seeps through the turntable drive into the appliance interior.
Door panels	Glass cleaner: Clean with a dish cloth. Do not use a glass scraper.
Grease filters	Hot soapy water: It's recommended to remove both filters from the bottom of the unit least once a month and soak in hot soapy water, then clean gently with a dish cloth and dry before replacing. Do not use glass cleaners or metal or glass scrapers for cleaning.
Seal	Hot soapy water: Clean with a dish cloth, do not scour. Do not use a metal or glass scraper for cleaning.

TROUBLESHOOTING

- Please review this list for common troubleshooting tips before calling for assistance, as this may save you time and money.
- This list contains frequently encountered problems that are not results of faulty workmanship or material use.
- Your product may not have some of the features described here.
- **If this list does not solve your concern, contact ZLINE Customer Service at 1-614-777-5004 for assistance.**

FAULT	POSSIBLE CAUSE	TROUBLESHOOTING
Oven won't start	Electrical cord is unplugged.	Plug into the outlet.
	Door is open.	Close the door and retry.
	Wrong operation is set.	Check instructions.
Arcing or sparking	Materials to be avoided in microwave oven were used.	Use microwave-safe cookware only.
	The oven is operated when empty.	Do not operate with oven empty.
	Spilled food remains in cavity.	Clean cavity with wet towel.
Unevenly cooked food	Materials to be avoided in microwave oven were used.	Use microwave-safe cookware only.
	Food is not defrosted completely.	Completely defrost food.
	Cooking time, power level is not suitable.	Use correct cooking time, power level.
	Food is not turned or stirred.	Turn or stir food.
Overcooked foods	Cooking time and/or power level is not suitable.	Use correct cooking time and/or power level.
Undercooked foods	Materials to be avoided in microwave were used.	Use correct cooking time and/or power level.
	Oven ventilation ports are restricted.	Check to see that oven ventilation ports are not restricted.
	Cooking time and/or power level is not suitable.	Use correct cooking time and/or power level.
	Food is not turned or stirred.	Turn or stir food.
Improper Defrosting	Materials to be avoided in microwave were used.	Use microwave-safe cookware only.
	Cooking time, power level is not suitable.	Use correct cooking time, power level.
	Food is not turned or stirred.	Turn or stir food.

WARRANTY

COVERAGE

ZLINE Kitchen and Bath ("ZLINE") microwave parts will be warrantied for two years from the original date of product delivery for the original purchaser of the product.

ZLINE warranty periods begin from the original date of product delivery and solely cover the original purchaser of the product, delivered new and in its original carton. ZLINE will provide free-of-charge, non-consumable replacement parts for the components that failed due to manufacturing defects.

It is the responsibility of the customer to install all replacement parts, as ZLINE does not perform service repairs on its microwave products.

ZLINE's liability is limited to the original purchase price of the product. Additional injuries, losses, damages, or other inconveniences caused by product malfunction or defects in materials are not covered under the terms of this warranty.

TERMS

ZLINE warranties apply only to the original purchaser of a ZLINE product installed for normal residential use. This is defined as a single-family, residential dwelling in a non-commercial setting. Any warranty claim stemming from installation, operation, or any other use within a commercial setting is not covered under this limited warranty.

Commercial settings include, but are not limited to: schools, churches, hotels, restaurants, vacation rentals such as Airbnb, daycare centers, private clubs, fire stations, common areas in multi-family dwellings, nursing homes, food service locations, and institutional food service locations such as hospitals or correctional facilities.

This warranty is non-transferable and will not under any circumstance be extended based on the date of installation — the warranty period takes effect from the date of delivery and only covers the original purchaser. The warranty applies only to products installed in the contiguous United States and the District of Columbia.

WARRANTY

Out-of-pocket payments will not be reimbursed for replacement parts unless prior approval is received from ZLINE. Unapproved out-of-pocket payments for parts will not be reimbursed. Out-of-pockets for any type of service will not be reimbursed, as ZLINE does not perform service repairs on its microwave products. All warranty procedures must be followed to maintain warranty coverage.

If ZLINE is unable to replace the defective part after a reasonable number of attempts, ZLINE reserves the right to offer to replace the product or provide the original purchaser a full refund of the purchase price of the product (not including installation, removal, or other charges that were not included in the original purchase price).

The original purchaser of the product must provide the original proof of purchase, including the purchase date, when filing a claim to obtain replacement parts or refunds. Additionally, the original purchaser of the product must provide the serial number of the product when filing a claim to obtain replacement parts or refunds.

This warranty shall not apply to any ZLINE product in which the original factory serial number has been removed, altered, or cannot be readily determined for any reason. Further, ZLINE is not responsible for damage resulting from, but not limited to: shipment, delivery, or improper installation; negligence or improper maintenance, misuse, or abuse of the product; unauthorized alteration, modification, or tampering with the product; accident, fire, floods, pest infestations, pandemics, natural disasters, or any other unpreventable or unexplained acts of nature, commonly referred to as "acts of God"; flare-up fires or damages caused by improper electric supply, electrical line current, voltage, or power surges; and service to correct installation not in accordance with the instructions contained in ZLINE's product manuals and/or with local government codes.

Additionally, this microwave warranty does not apply to aesthetic damage, scratches, or natural wear caused by normal use; second-hand, open box products, or products purchased from an unauthorized retailer; consumable parts including, but not limited to, metal and charcoal filters; and damages, problems, or any type of performance-related issues stemming from alteration or tampering with the microwave, including, but not limited to, painting stainless steel, black stainless, or DuraSnow® finishes or any portion of the product's interior or exterior, and cutting the 3-prong plug to manually hardwire the product.

WARRANTY

Information contained within ZLINE's installation and user manuals, in addition to product information included on ZLINE's website and all related digital listings, do not cover every possible condition and situation that may occur during the installation or operation of ZLINE products.

ZLINE reserves the right to make changes at any time to its products when considered safe, necessary, and useful. Always check the ZLINE website for the most up-to-date version of its product manuals: www.zlinekitchen.com/pages/manuals.

Do not install or operate any ZLINE product if it has missing or broken parts or if it arrives damaged due to shipping. If ZLINE products arrive damaged, contact ZLINE Customer Experience at 1-614-777-5004 for help. Failure to report a damaged appliance prior to installation or operation may void the warranty. ZLINE does not perform service repairs on its microwave products.

ZLINE disclaims responsibility for damage or injury caused by improper installation or use of any of its products. ZLINE is under no obligation, by law or otherwise, to provide concessions, including repairs, prorates, rebates, discounts, or replacements, once the warranty has expired.

SERIAL NUMBER LOCATION

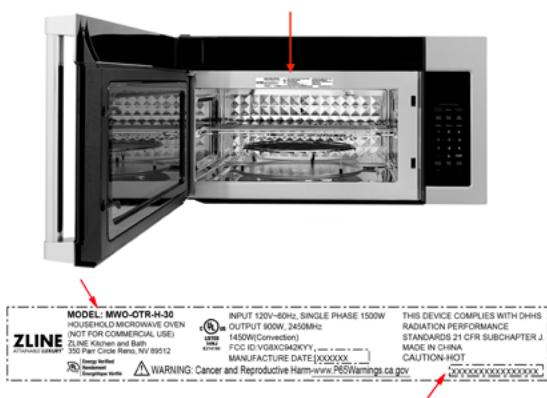

The rating tag shows the model and serial number of your appliance. Please write down the model number and serial number of your appliance. The serial number is located on the front of the microwave. The tag is visible when the microwave door is open. Both are needed to obtain warranty assistance. Do not remove permanently affixed labels, warnings, or plates from the product. This will void the warranty. You may also consider attaching your receipt or proof of purchase to this manual.

WARRANTY

CUSTOMER SERVICE AND PARTS INFORMATION



Please contact ZLINE Customer Service for questions and troubleshooting help at 1-614-777-5004 or visit www.zlinekitchen.com/contact to utilize our online Customer Experience Portal.



Scan the QR code to view the most up-to-date version of our Installation Manual and User Manual.



Need to purchase a part or accessory for your ZLINE product? Visit www.zlineparts.com, ZLINE's official parts distribution partner.

2.1.3

1-614-777-5004

www.zlinekitchen.com

contact@zlinekitchen.com

ZLINE
ATTAINABLE LUXURY®