



GE APPLIANCES
a Haier company

Service Manual

NS23AM
HIGH EFFICIENCY AIR
CONDITIONER SYSTEM UP TO 23
SEER (22 SEER2)



**READ CAREFULLY.
KEEP THESE INSTRUCTIONS.**

SERVICE MANUAL

NS23AM



This is a safety alert symbol and should never be ignored. When you see this symbol on labels or in manuals, be alert to the potential for personal injury or death.

WARNING

Improper installation, adjustment, alteration, service or maintenance can cause property damage, personal injury or loss of life. Installation and service must be performed by a licensed professional HVAC installer or equivalent, service agency, or the gas supplier.

WARNING

To prevent serious injury or death:

Lock-out/tag-out before performing maintenance.

If system power is required (e.g., smoke detector maintenance), disable power to blower, remove fan belt where applicable, and ensure all controllers and thermostats are set to the "OFF" position before performing maintenance.

Always keep hands, hair, clothing, jewelry, tools, etc. away from moving parts.

Table of Contents

Technical Specifications	3
Typical Unit Parts Arrangement	6
General Information	9
Operating Gauge Set and Service Valves	9
Installation	10
New or Replacement Line Set	12
Electrical - Circuit Sizing and Wire Routing	23
Thermostat Control and Low Voltage Control Wiring	23
Outdoor Unitary Control	27
Unit Operation	28
Servicing Units Delivered Void of Charge	31
Start-Up	31
System Operation and Service	32
Unit Selection Code for Outdoor Control	47
Configuring Unit	51
System Overview	52
Maintenance	52
Unit Wiring Diagram	54
Unit Sequence of Operation	55
Component Testing	58
System Refrigerant	91
Charge Mode Jumper	91

IMPORTANT

This unit must be matched with an indoor coil as specified with AHRI. For AHRI Certified system match-ups and expanded ratings, visit www.AHRIdirectory.org. Coils previously charged with HCFC-22 must be flushed.

Technical Specifications

MODEL NUMBER GUIDE

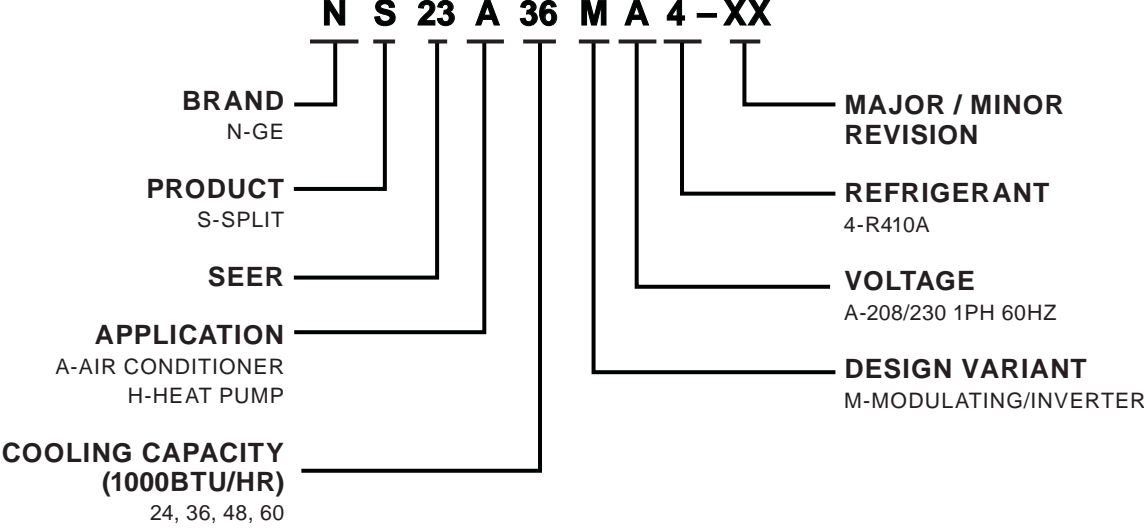

PHYSICAL AND ELECTRICAL DATA

Model	Voltage/Hz/Phase	Voltage Range	Min. Circuit Amp.	Max. Over Current Device (amps)	Compressor		Outdoor Fan Motor		
					Rated Load (amps)	Locked Rotor (amps)	Full Load (amps)	Rated HP	Nom. RPM
NS23A24MA4	208-230/60/1	197-253	12.6	20	8.0	14	2.6	1/3	Var. Spd.
NS23A36MA4	208-230/60/1	197-253	19.2	30	13.3	14			
NS23A48MA4	208-230/60/1	197-253	23.6	40	16.8	23			
NS23A60MA4	208-230/60/1	197-253	27.4	45	19.8	23			

UNIT DIMENSIONS (IN.)

Model	Dimensions (inch)			Shipping Weight (Lbs.)
	A - Width	B - Depth	C - Height	
NS23A24MA4	37.75	35.75	37.50	230
NS23A36MA4	37.75	35.75	37.50	230
NS23A48MA4	37.75	35.75	43.75	300
NS23A60MA4	37.75	35.75	43.75	300

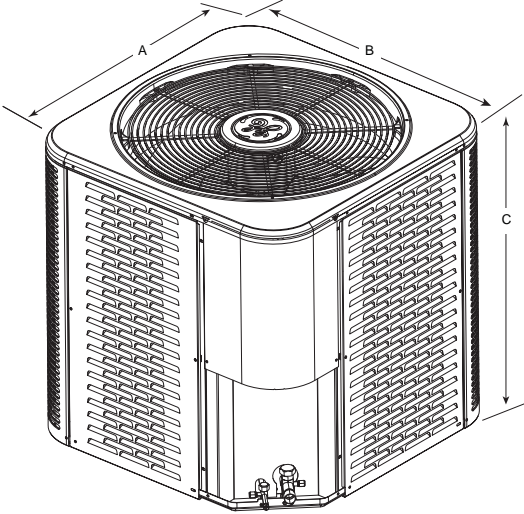

Note: Dimensions listed are unit sizes w/o packaging
Weights listed are unit weights with packaging

NOTE: Appearances may vary.

SOUND RATINGS

Model	Sound Power ¹ (Low)	Estimated Sound Pressure (dBA) ²			Sound Power ¹ (High)	Estimated Sound Pressure (dBA) ²		
		Approximate Distance ³				Approximate Distance ³		
		One Meter (3.3 feet)	Two Meters (6.6 feet)	Three Meters (9.8 feet)		One Meter (3.3 feet)	Two Meters (6.6 feet)	Three Meters (9.8 feet)
NS23A24MA4	62	54	48	44	71	63	57	53
NS23A36MA4	62	54	48	44	75	67	61	57
NS23A48MA4	65	57	51	47	76	68	62	58
NS23A60MA4	65	57	51	47	76	68	62	58

¹ Rated in accordance with AHRI standard 270 (2015)

² Rated in accordance with AHRI standard 275 (2010)

³ Based only on distance factor; other factors may change this value such as:

- Unit location (reflective surfaces adjacent to the unit)
- Barrier shielding sources
- Sound path/elevation
- Outside noise sources

REFRIGERATION DATA

Model	Refrig. Charge (oz.) [*]	TXV	Refrigerant Line Size		Outdoor Unit Connection		Indoor Unit Connection	
			Suction	Liquid	Suction	Liquid	Suction	Liquid
NS23A24MA4	127	H4TXV01	3/4	3/8	3/4	3/8	3/4	3/8
NS23A36MA4	128	H4TXV02	7/8		7/8		7/8	
NS23A48MA4	190	H4TXV03	7/8		7/8		7/8	
NS23A60MA4	191	H4TXV03	1-1/8		1-1/8		7/8	

^{*} Factory charged for 15 feet of line set; adjust per installation instructions

NOTE: Refrigerant charge also varies with indoor unit; refer to refrigerant charge label

COOLING PERFORMANCE WITH DTC¹

Outdoor Model	Indoor Model	Cooling			
	Evap. Coil or Air Handler ³	SEER ²	EER ²	AHRI Rated Capacity ²	Sensible Capacity
NS23A24MA4	NAM24V2TA4	21.2	14.0	23,200	18,000
NS23A36MA4	NAM36V2TA4	21.4	12.5	35,000	26,600
NS23A48MA4	NAM48V2TA4	20.8	12.5	46,000	35,000
NS23A60MA4	NAM60V2TA4	19.6	12.0	55,500	41,150

Note:

¹ DTC = Designated tested combination

² Certified in accordance with Unitary Air Conditioner Certification Program, which is based on AHRI Standard 210/240

³ A blower time delay relay is standard on all GE Appliances furnace and air handler products

FAN BLADE SPECS

NS23A	Fan Blade			
	Dia.	#of Blades	Pitch	Part #
24	26"	3	28	100017-02
36, 48, 60	26"	3	20	100017-03

ACCESSORIES

Description	Where Used	Kit Number
H4TXV01 (TXV Kit)	24	1.851363
H4TXV02 (TXV Kit)	36	1.851364
H4TXV03 (TXV Kit)	48, 60	1.851365
Freezestat	3/8 tubing	93G35
Crankcase Heater	All models	Factory Installed
Sound Cover	All models	Factory Installed
Loss of Charge Kit	All models	Factory Installed
Discharge Temperature Sensor	All models	88K38

Typical Unit Parts Arrangement

-24, -36 Units

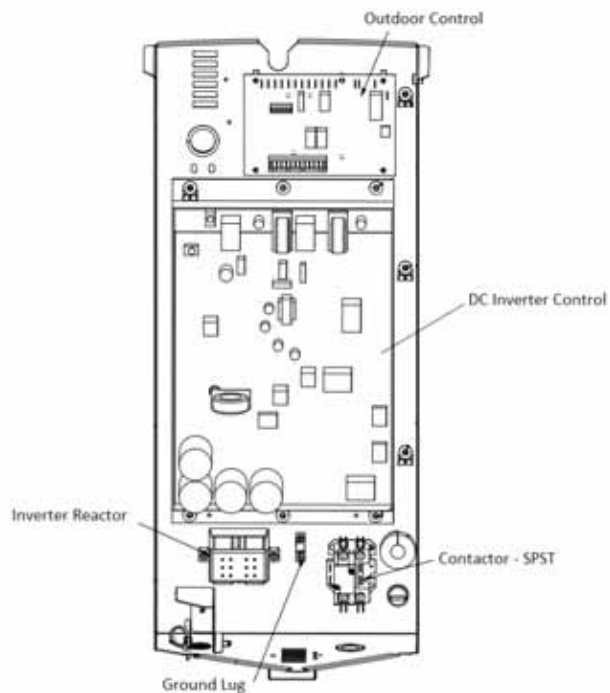

-48, -60 Units

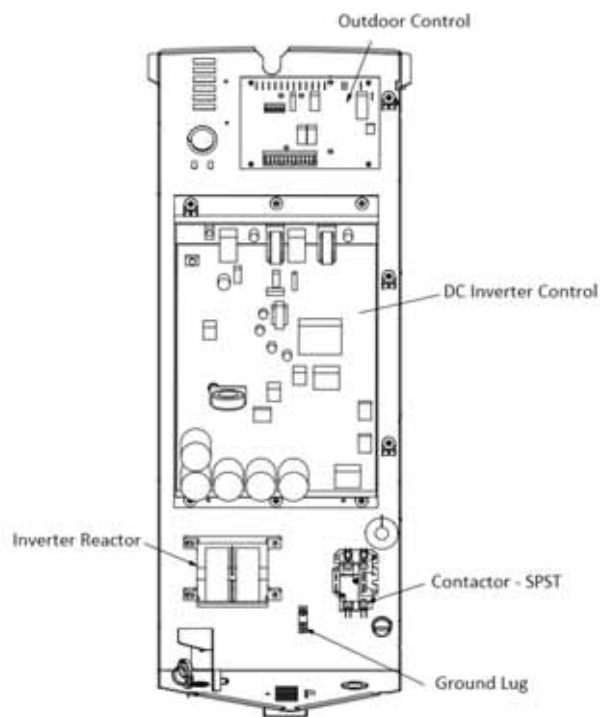

Figure 1. Control Panel Components

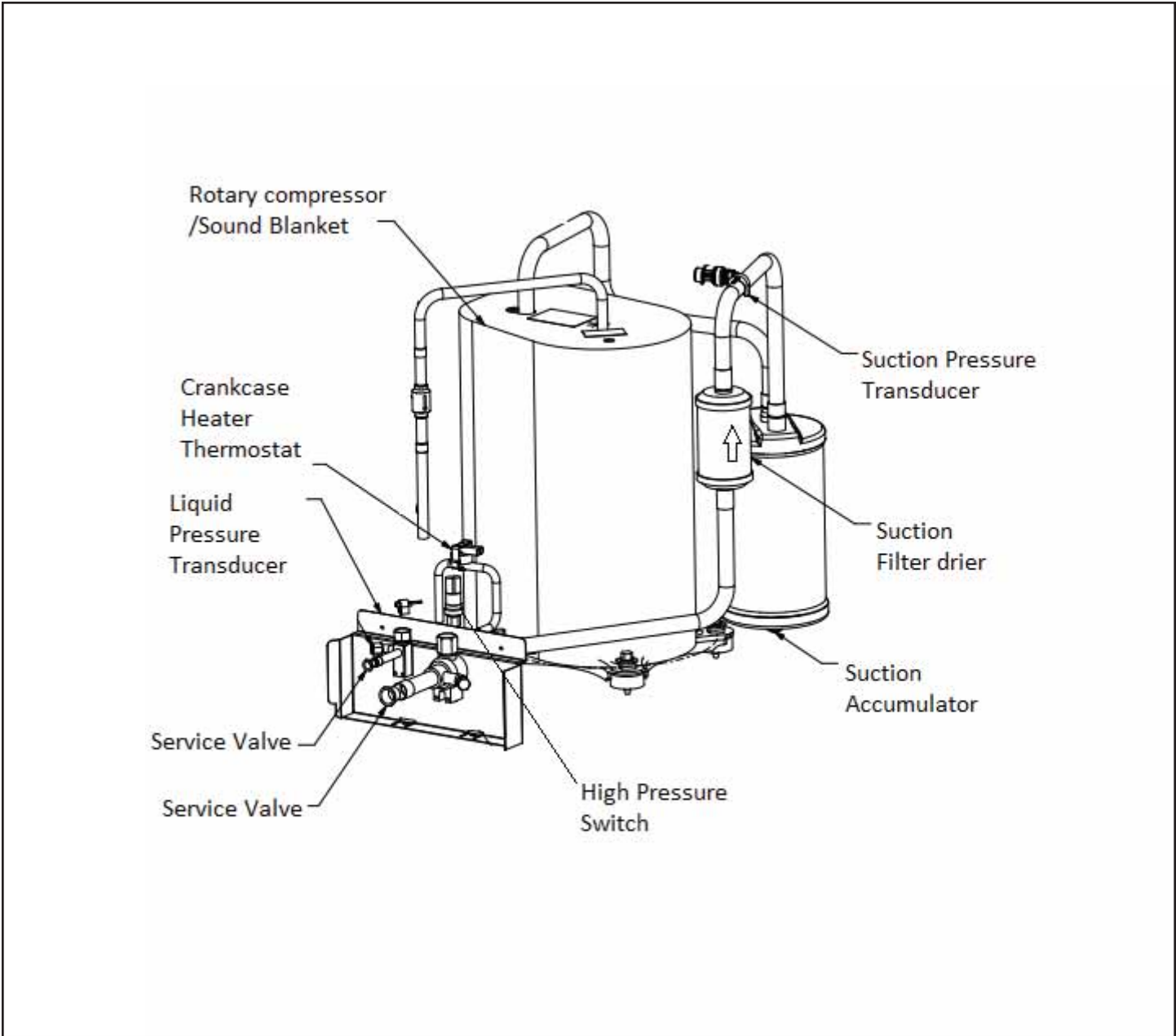

Figure 2. Component Locations NS23A24M, 36M, 48M

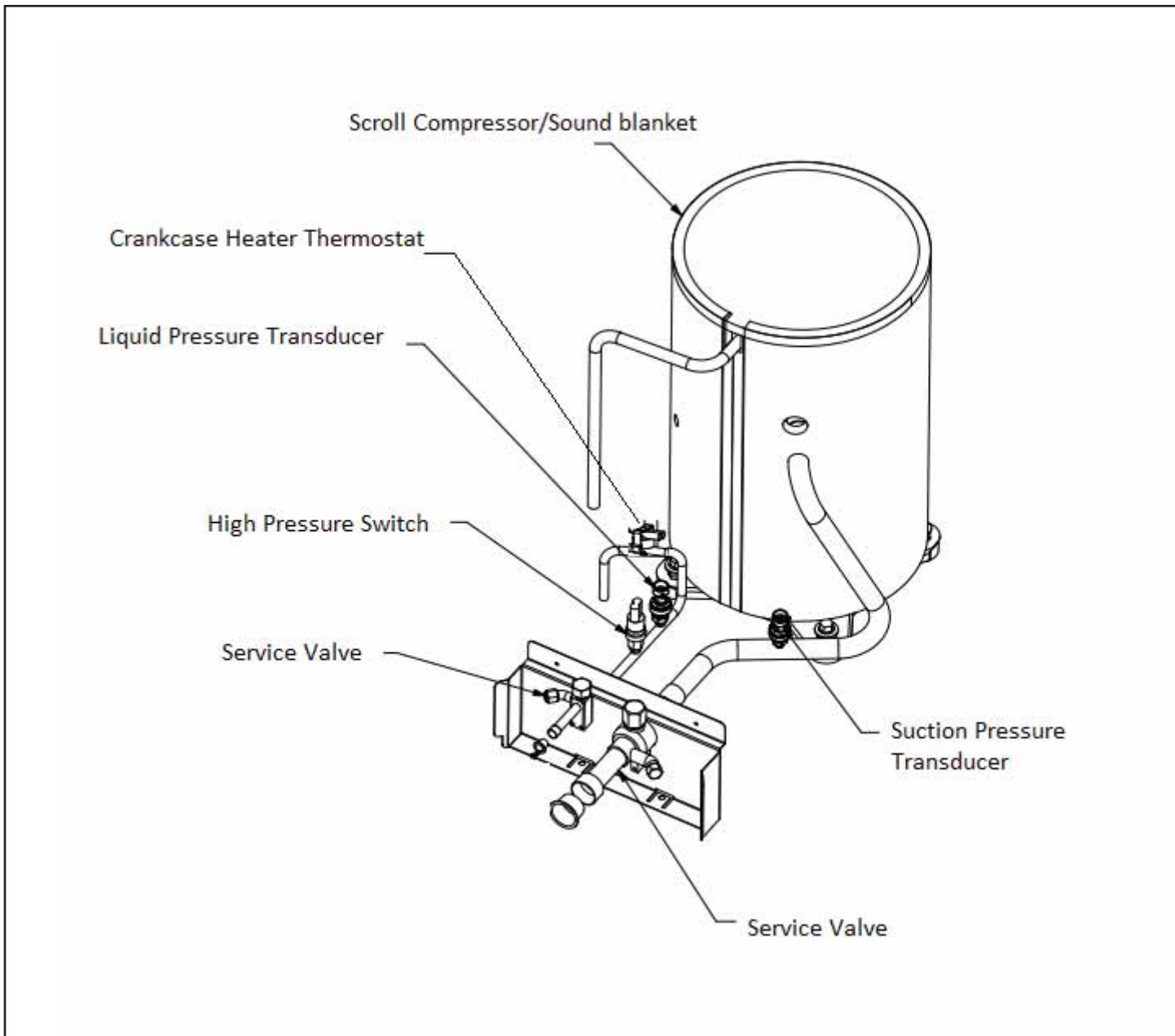

Figure 3. Component Locations NS23A60M (Scroll Compressor Model)

CAUTION

As with any mechanical equipment, contact with sharp sheet metal edges can result in personal injury. Take care while handling this equipment and wear gloves and protective clothing.

General Information

These instructions are intended as a general guide and do not supersede national or local codes in any way. Consult authorities having jurisdiction before installation.

The NS23AM is a high-efficiency split system air conditioner **with all-aluminum coil**, designed for use with HFC-410A refrigerant only.

The NS23A24M, 36M and 48M feature a variable capacity rotary compressor. The NS23A60M model features a variable capacity scroll compressor.

This unit must be installed with an approved indoor air handler or coil. For AHRI Certified system match-ups and expanded ratings, visit www.AHRIdirectory.org. These instructions are intended as a general guide and do not supersede local codes in any way. Consult authorities having jurisdiction before installation.

This outdoor unit is designed for use in systems that use a Thermal expansion valve (TXV).

NOTE: *Special procedures are required for cleaning the all-aluminum coil in this unit.*

WARNING

Electric shock hazard.



Can cause injury or death. Before attempting to perform any service or maintenance, turn the electrical power to unit OFF at disconnect switch(es). Unit may have multiple power supplies.

Operating Gauge Set and Service Valves

Torque Requirements

When servicing or repairing heating, ventilating, and air conditioning components, ensure the fasteners are appropriately tightened. Table 1 lists torque values for fasteners.

IMPORTANT

Only use Allen wrenches of sufficient hardness (50Rc - Rockwell Harness Scale minimum). Fully insert the wrench into the valve stem recess.

Service valve stems are factory-torqued (from 9 ft-lbs for small valves, to 25 ft-lbs for large valves) to prevent refrigerant loss during shipping and handling. Using an Allen wrench rated at less than 50Rc risks rounding or breaking off the wrench, or stripping the valve stem recess.

IMPORTANT

To prevent stripping of the various caps used, the appropriately sized wrench should be used and fitted snugly over the cap before tightening.

Parts	Recommended Torque	
Service valve cap	8 ft.-lb.	11 NM
Sheet metal screws	16 in.-lb.	2 NM
Machine screws #10	28 in.-lb.	3 NM
Compressor bolts	90 in.-lb.	10 NM
Gauge port seal cap	8 ft.-lb.	11 NM

Table 1. Torque Requirements

Using Manifold Gauge Set

When checking the system charge, only use a manifold gauge set that features low loss anti-blow back fittings.

Manifold gauge set used with HFC-410A refrigerant systems must be capable of handling the higher system operating pressures. The gauges should be rated for use with pressures of 0 - 800 psig on the high side and a low side of 30" vacuum to 250 psig with dampened speed to 500 psi. Gauge hoses must be rated for use at up to 800 psig of pressure with a 4000 psig burst rating.

Operating Service Valves

The liquid and vapor line service valves are used for removing refrigerant, flushing, leak testing, evacuating, checking charge and charging. Each valve is equipped with a service port which has a factory-installed valve stem. Figure 4 through Figure 6 provide information on access and operation of both angle and ball service valves.

OPERATING BALL-TYPE SERVICE VALVE

- 1 - Remove stem cap with an appropriately sized wrench.
- 2 - Use an appropriately sized wrench to open. To open valve, rotate stem counterclockwise 90°. To close, rotate stem clockwise 90°.

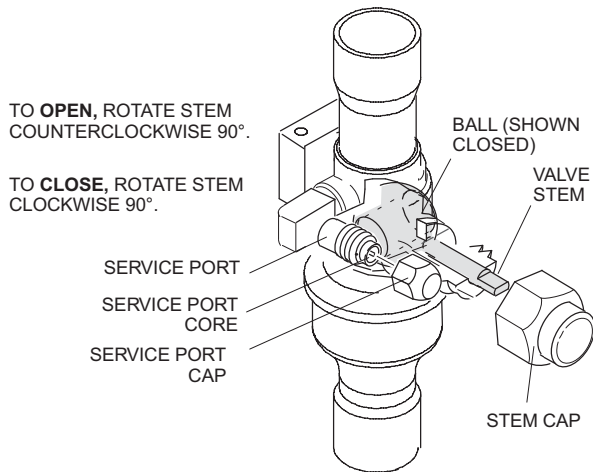
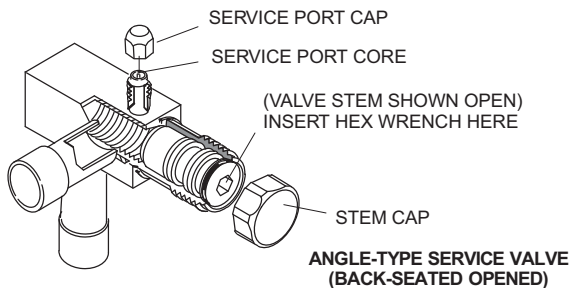

Figure 4.

OPERATING ANGLE-TYPE SERVICE VALVE

- 1 - Remove stem cap with an appropriately sized wrench.
- 2 - Use a service wrench with a hex-head extension (3/16" for liquid line valve sizes and 5/16" for vapor line valve sizes) to back the stem out counterclockwise as far as it will go.



When service valve is **OPEN**, the service port is open to line set, indoor and outdoor unit.

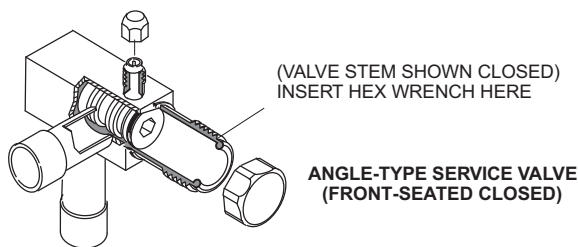

When service valve is **CLOSED**, the service port is open to the line set and indoor unit.

NOTE - A label with specific torque requirements may be affixed to the stem cap. If the label is present, use the specified torque.

Figure 5.

ACCESS SERVICE PORT

A service port cap protects the service port core from contamination and serves as the primary leak seal.

- 1 - Remove service port cap with an appropriately sized wrench.
- 2 - Connect gauge set to service port.
- 3 - When testing is completed, replace service port cap and tighten as follows:
 - With torque wrench, finger tighten and torque cap per table 2.
 - Without torque wrench, finger tighten and use an appropriately sized wrench to turn an additional 1/6 turn clockwise.

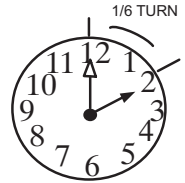

Reinstall Stem Cap

Stem cap protects the valve stem from damage and serves as the primary seal. Replace the stem cap and tighten as follows:

- With torque wrench, finger tighten and then torque cap per table 2.
- Without torque wrench, finger tighten and use an appropriately sized wrench to turn an additional 1/12 turn clockwise.

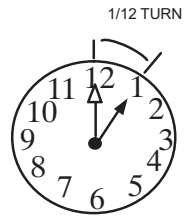

Figure 6.

Installation

NOTE: In some cases, noise in the living area has been traced to gas pulsations from improper installation of equipment.

- Locate unit away from windows, patios, decks, etc. where unit operation sounds may disturb customer.
- Leave some slack between structure and unit to absorb vibration.
- Place a sound-absorbing material, such as Isomode, under the unit if it will be installed in a location or position that will transmit sound or vibration to the living area or adjacent buildings.
- Install the unit high enough above the ground or roof to allow adequate drainage of defrost water and prevent ice buildup.
- In heavy snow areas, do not locate the unit where drifting snow will occur. The unit base should be elevated above the depth of average snows.

NOTE: Elevation of the unit may be accomplished by constructing a frame using suitable materials. If a support frame is constructed, it must not block drain holes in unit base.

- When installed in areas where low ambient temperatures exist, locate unit so winter prevailing winds do not blow directly into outdoor coil.
- Locate unit away from overhanging roof lines which would allow water or ice to drop on, or in front of, coil or into unit.

⚠ WARNING

To prevent personal injury, as well as damage to panels, unit or structure, observe the following:

While installing or servicing this unit, carefully stow all removed panels so that the panels will not cause injury to personnel, objects or nearby structures. Also, take care to store panels where they will not be subject to damage (e.g., being bent or scratched).

While handling or stowing the panels, consider any weather conditions (especially wind) that may cause panels to be blown around and damaged.

⚠ IMPORTANT

Exhaust vents from dryers, water heaters and furnaces should be directed away from the outdoor unit. Prolonged exposure to exhaust gases and the chemicals contained within them may cause condensation to form on the steel cabinet and other metal components of the outdoor unit. This will diminish unit performance and longevity.

When outdoor unit is connected to factory-approved indoor unit, outdoor unit contains system refrigerant charge for operation with matching indoor unit when connected by 15 ft. of field-supplied tubing. For proper unit operation, check refrigerant charge using charging information located on control box cover.

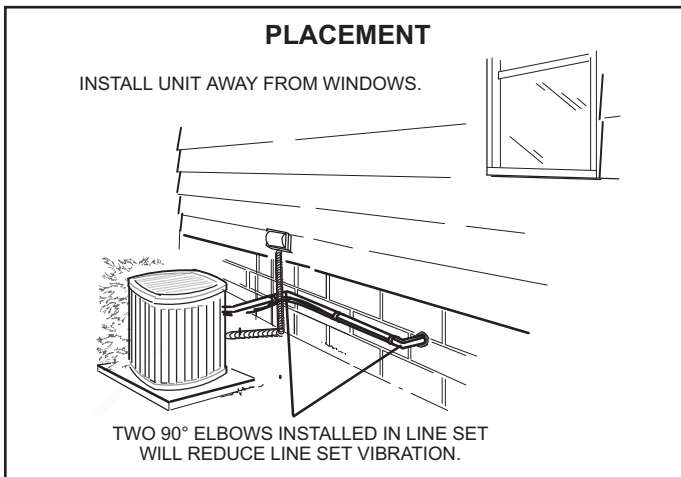

Figure 7.

Outdoor Section

Zoning ordinances may govern the minimum distance the condensing unit can be installed from the property line.

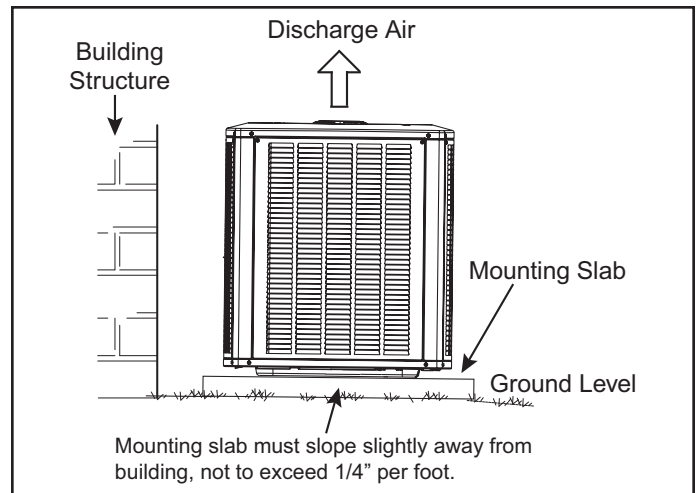

Figure 8. Slab Mounting

Install on a Solid, Level Mounting Pad

The outdoor section is to be installed on a solid foundation. This foundation should extend a minimum of 2" (inches) beyond the sides of the outdoor section. To reduce the possibility of noise transmission, the foundation slab should NOT be in contact with or be an integral part of the building foundation. See Figure 8.

If conditions or local codes require the unit be attached to pad or mounting frame, tie down bolts should be used and secured to unit base pan.

Elevate Unit

⚠ CAUTION

Accumulation of water and ice in base pan may cause equipment damage.

Elevate unit per local climate and code requirements to provide clearance above estimated snowfall level and ensure adequate drainage of unit. Use snow stand in areas where prolonged freezing temperatures are encountered.

If conditions or local codes require the unit be attached to pad or mounting frame, tie down bolts should be used and fastened through knockouts provided in unit base pan.

Clearance Requirements

When installing, allow sufficient space for airflow clearance, wiring, refrigerant piping, and service. For proper airflow, quiet operation and maximum efficiency. Position so water, snow, or ice from roof or eaves cannot fall directly on unit. Refer to Table 2 for installation clearances.

Location	Minimum Clearance
Service box	30"
Top of unit*	48"
Between units	24"
Against wall	6"

* Maximum soffit overhang is 36".

NOTE: At least one side should be unobstructed by a wall or other barrier.

Table 2. Clearances

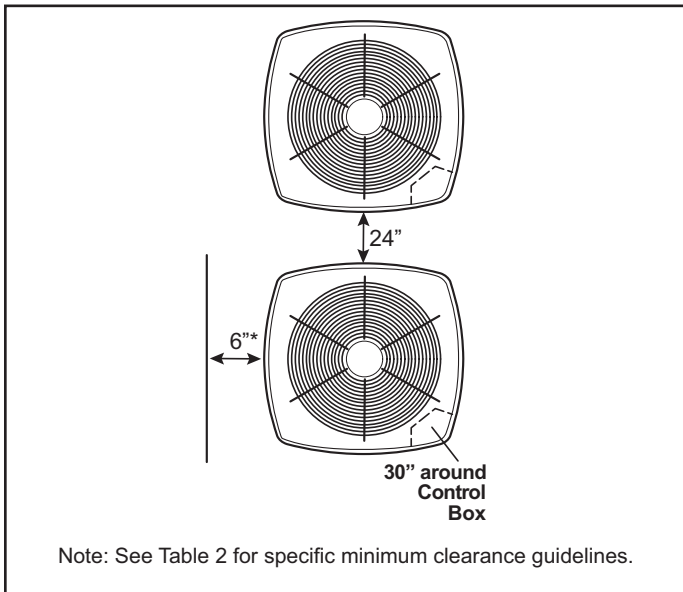

Figure 9.

DO LOCATE THE UNIT:

- With proper clearances on sides and top of unit
- On a solid, level foundation or pad (unit must be level to within $\pm 1/4$ in./ft. per compressor manufacturer specifications)
- To minimize refrigerant line lengths

DO NOT LOCATE THE UNIT:

- On brick, concrete blocks or unstable surfaces
- Near clothes dryer exhaust vents
- Near sleeping area or near windows
- Under eaves where water, snow or ice can fall directly on the unit
- With clearance less than 2 ft. from a second unit
- With clearance less than 4 ft. on top of unit

New or Replacement Line Set

! IMPORTANT

If this unit is being matched with an approved line set or indoor unit coil that was previously charged with mineral oil, or if it is being matched with a coil which was manufactured before January of 1999, the coil and line set must be flushed prior to installation. Take care to empty all existing traps. Polyvinyl ether (PVE) and polyol ester (POE) oils are used in GE Appliances variable-capacity units charged with HFC-410A refrigerant. Residual mineral oil can act as an insulator, preventing proper heat transfer. It can also clog the expansion device and reduce system performance and capacity. Failure to properly flush the system per this instruction and the detailed Installation and Service Procedures manual will void the warranty.

Flush the existing line set per the following instructions. For more information, refer to the Installation Instruction. **CAUTION - DO NOT** attempt to flush and re-use existing line sets or indoor coil when the system contains contaminants (i.e., compressor burn out).

Polyvinyl ether (PVE) oil is used in the NS23A24M, 36M, and 48M with rotary compressors. For installations of the NS23A24M, 36M, and 48M units with refrigerant lines or coils previously charged with R410A and POE oil, GE Appliances recommends flushing the existing lines and coil with R410A refrigerant to remove excess POE oil that may be in the system. The NS23A60M air conditioners have variable capacity scroll compressors that use POE oil. NS23A60M units with refrigerant lines or coils previously charged with R410A and POE oil, do not need to be flushed to remove the POE oil.

If a new line set is being installed, size the piping per Table 3.

Model	23 SEER	
	Liquid Line	Suction Line
24	3/8	3/4
36	3/8	7/8
48	3/8	7/8
60	3/8	1-1/8

* Fittings should be supplied by the installer.
 NOTE - Some applications may require a field-provided 7/8" to 1-1/8" adapter.

Table 3.

NOTE: Special consideration must be taken for line sets over 50 feet. See Refrigerant Piping Guidelines.

⚠ WARNING



When using a high pressure gas such as nitrogen to pressurize a refrigeration or air conditioning system, use a regulator that can control the pressure down to 1 or 2 psig (6.9 to 13.8 kPa).

⚠ WARNING

Refrigerant can be harmful if it is inhaled. Refrigerant must be used and recovered responsibly.

Failure to follow this warning may result in personal injury or death.

⚠ WARNING



Fire, Explosion and Personal Safety hazard. Failure to follow this warning could result in damage, personal injury or death.



Never use oxygen to pressurize or purge refrigeration lines. Oxygen, when exposed to a spark or open flame, can cause fire and/or an explosion, that could result in property damage, personal injury or death.

⚠ WARNING

Polyvinyl ether (PVE) oils used with HFC-410A refrigerant absorb moisture very quickly. It is very important that the refrigerant system be kept closed as much as possible. DO NOT remove line set caps or service valve stub caps until you are ready to make connections.

The NS23AM is a variable-capacity cooling system utilizing variable speed compressor technology. With the variable speed compressor and variable pumping capacity, additional consideration must be given to refrigerant piping sizing and application. The guidelines below are to be used exclusively for the NS23AM systems.

Cooling System (HFC410a)

- Total equivalent length equals 180 feet (piping and all fittings included).

NOTE: Length is general guide. Lengths may be more or less, depending on remaining system design factors.

- Maximum linear (actual) length = 150 feet.
- Maximum linear liquid lift = 60 feet.

NOTE: Maximum lifts are dependent on total length, number of elbows, etc. that contribute to total pressure drop.

- Maximum length vapor riser = 60 feet.
- **Up to 50 Linear Feet:** Use rated line sizes listed in Table 4.
- **Between 51 and 150 Linear Feet:** Crankcase heater and nonbleed port TXV factory installed. No additional components required. Vertical vapor riser must be sized to the vapor riser listed in Table 5 on systems with line sets longer than 51 feet. Use Table 5 and Table 6 to determine the correct liquid and vapor line sizes.
- **Over 150 Linear Feet:** not recommended.
- Additional oil is not required for systems with line lengths up to 150 feet.

Suction Traps

For systems with the outdoor unit 5 - 60 feet above the indoor unit, one trap must be installed at the bottom of the suction riser.

Tonnage *	Valve Size Connections		Recommended Line Sets
	Liquid Line	Suction Line	Line Set Length
24M	3/8" (10mm)	3/4" (19mm)	30' (9.1m)
36M		7/8" (22mm)	40' (12.2m)
48M			50' (15.2m)
60M		1-1/8" (29mm) **	Field-fabricated

* Applicable to all minor revision numbers unless otherwise specified.

** Some applications may require a field-provided 1-1/8" to 7/8" adapter.

Table 4. Standard Refrigerant Line Set – Up to 50 Linear Feet in Length

Tonnage	Maximum Total Equivalent Length (ft)	Maximum Linear (actual) Length (ft)	Maximum Vapor Riser (ft)	Maximum Linear Liquid Lift (ft)	Preferred Vapor Line Sizes for Horizontal Runs	Required Vapor Riser Size
24	180	150	60	60	7/8"	5/8"
36						3/4"
48						7/8"
60						

Table 5. NS23AM Line Set Guidelines – 51 to 150 Linear Feet in Length

Tonnage	Line Size	Total Linear Length (ft.)						Max Elevation (ft)
		25	50	75	100	125	150	
24	5/16"	25	50	55	48	40	33	
	3/8"	25	50	60	60	60	60	
36	3/8"	25	50	60	56	51	45	
	1/2"	25	50	60	60	60	60	
48	3/8"	25	50	50	41	31	22	
	1/2"	25	50	60	60	60	60	
60	3/8"	25	50	36	22	8	NR	
	1/2"	25	50	60	60	60	59	

NOTE: Shaded rows indicate rated liquid line size.

- A. Find your tonnage on the left side of the table.
- B. Start with the rated liquid line size (shaded row) on the outdoor tonnage.
- C. Select the actual Total Linear Length of your system shown at the top of the table.
- D. The elevation listed in the table is the maximum allowed for the liquid line listed.
- E. Select or consider the larger liquid line size shown in the table if the elevation does not meet your requirements.

NOTE: For new or replacement line set installation, refer to Refrigerant Piping Guidelines Publication Number 31-5000722.

Table 6. Liquid Line Diameter Selection

LINE SET

IMPORTANT — Refrigerant lines must not contact structure.

INSTALLATION

Line Set Isolation — The following illustrations are examples of proper refrigerant line set isolation:

REFRIGERANT LINE SET — TRANSITION FROM VERTICAL TO HORIZONTAL

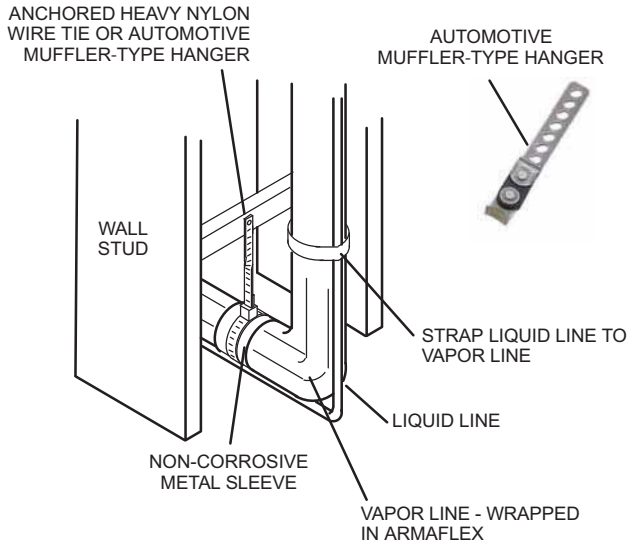

REFRIGERANT LINE SET — INSTALLING HORIZONTAL RUNS

To hang line set from joist or rafter, use either metal strapping material or anchored heavy nylon wire ties.

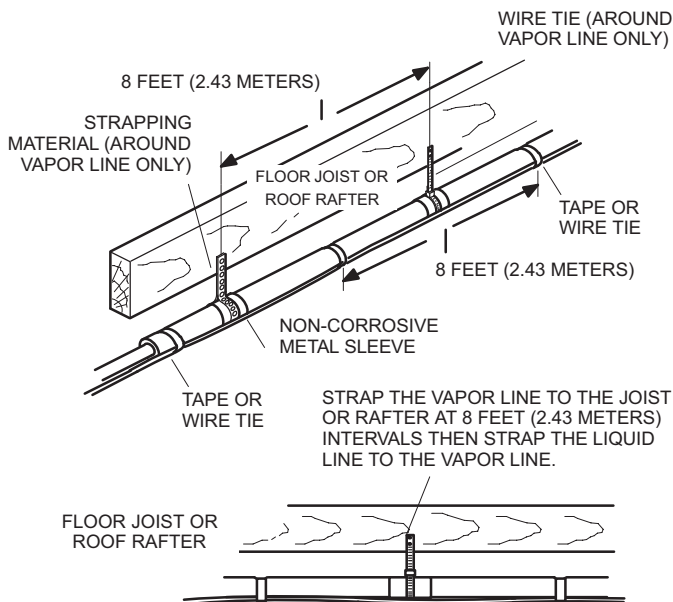

REFRIGERANT LINE SET — INSTALLING VERTICAL RUNS (NEW CONSTRUCTION SHOWN)

NOTE — Insulate liquid line when it is routed through areas where the surrounding ambient temperature could become higher than the temperature of the liquid line or when pressure drop is equal to or greater than 20 psig.

IMPORTANT — Refrigerant lines must not contact wall

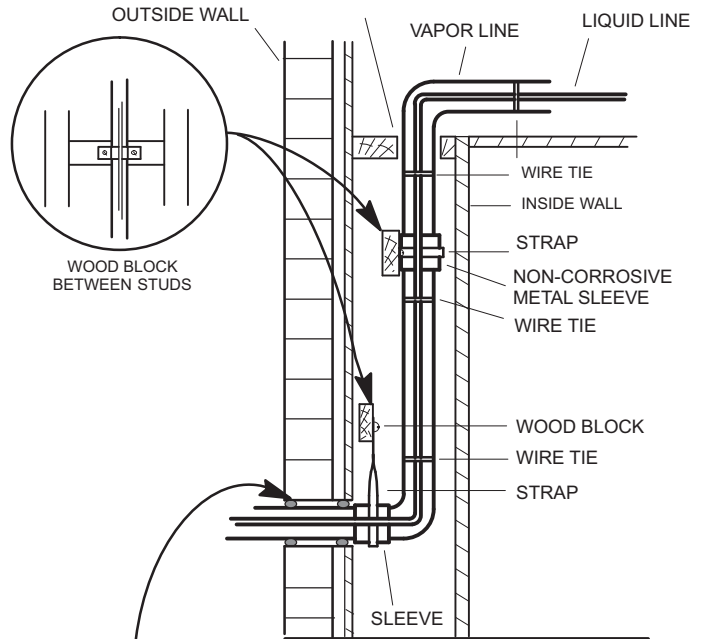

NOTE — Similar installation practices should be used if line set is to be installed on exterior of outside wall.

It is recommended that vertical suction risers not be up-sized. Proper oil return to the compressor should be maintained with suction gas velocity.

Filter Drier

The filter drier is very important for proper system operation and reliability. If the drier is shipped loose, it must be installed by the installer in the field. Unit warranty will be void, if the drier is not installed.

NOTE: The suction filter drier is factory installed on 24, 36, and 48 units. The liquid filter drier is factory installed on 60 units.

Installation of Line Sets

DO NOT fasten liquid or suction lines in direct contact with the floor or ceiling joist. Use an insulated or suspension type of hanger. Keep both lines separate, and always insulate the suction line. Liquid line runs (30 feet or more) in an attic will require insulation. Route refrigeration line sets to minimize length.

DO NOT let refrigerant lines come in direct contact with foundation. When running refrigerant lines through the foundation or wall, openings should allow for a sound and vibration absorbing material to be placed or installed between tubing and foundation. Any gap between foundation or wall and refrigerant lines should be filled with a vibration damping material.

CAUTION

If ANY refrigerant tubing is required to be buried by state or local codes, provide a 6 inch vertical rise at service valve.

Installation into an Existing R-22 System

If the unit will be installed in an existing system that uses an indoor unit or line sets charged with R-22 refrigerant, installer must perform the following procedures to convert the system to an R-410A system.

Typical Existing Fixed Orifice Removal Procedure

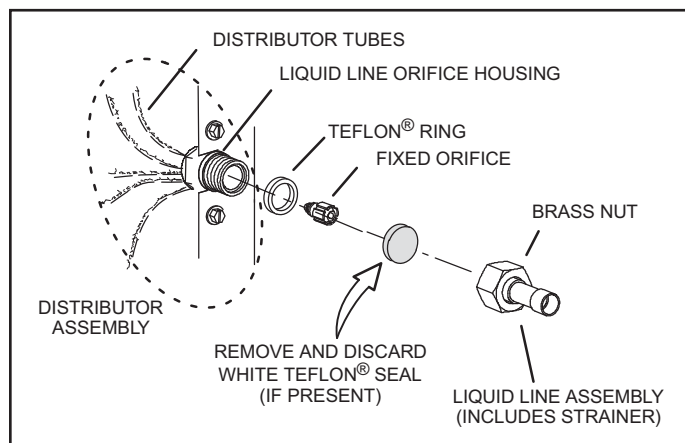

Figure 10. Remove Fixed Orifice (Uncased Coil Shown)

1. On fully cased coils, remove the coil access and plumbing panels.
2. Remove any shipping clamps from the liquid line and distributor assembly.
3. Using two wrenches (one to hold the orifice housing and one to remove the brass nut), disconnect liquid line from liquid line orifice housing. Take care not to twist or damage distributor tubes during this process.
4. Remove and discard fixed orifice, valve stem assembly (if present) and Teflon® washer, as shown in Figure 10.
5. Use a field-provided fitting to temporarily reconnect the liquid line to the indoor unit's liquid line orifice housing.

Remove Existing Expansion Valve

1. On fully cased coils, remove the coil access and plumbing panels.
2. Remove any shipping clamps from the liquid line and distributor assembly.
3. Disconnect the equalizer line from the check expansion valve equalizer line fitting on the vapor line.
4. Remove the vapor line sensing bulb.
5. Disconnect the liquid line from the check expansion valve at the liquid line assembly.
6. Disconnect the check expansion valve from the liquid line orifice housing. Take care not to twist or damage distributor tubes during this process.
7. Remove and discard check expansion valve and the two Teflon® rings (see Figure 11).
8. Use a field-provided fitting to temporarily reconnect the liquid line to the indoor unit's liquid line orifice housing.

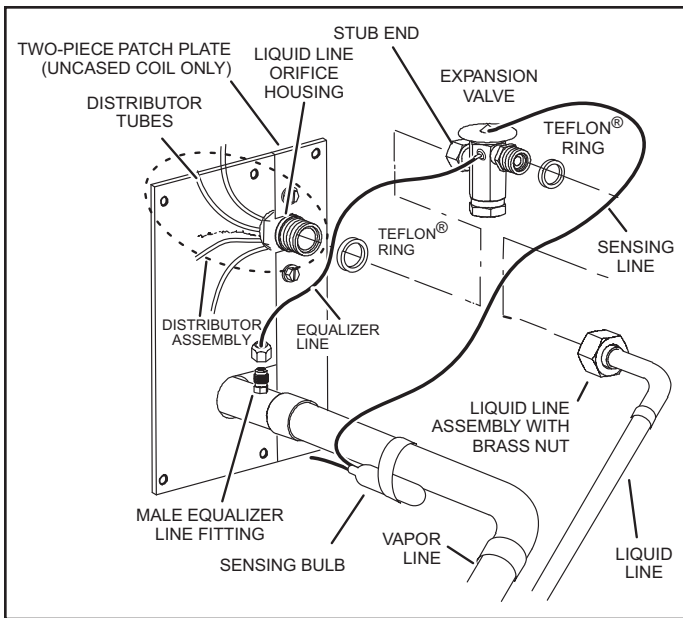

Figure 11. Remove Existing Expansion Valve (uncased coil shown)

Flushing Line Sets

If the unit will be installed in an existing system that uses an indoor unit or line sets charged with R-22 refrigerant, installer must perform the following flushing procedure.

NOTE: Existing system components (including line set and indoor coil) must be an AHRI match with the unit in order to fulfill unit warranty requirements.

⚠ WARNING

Refrigerant must be reclaimed in accordance with national and local codes.

⚠ CAUTION

Do **NOT** attempt to flush and re-use existing line sets or indoor coil when the system contains contaminants (i.e., compressor burn out).

NOTE

“Clean refrigerant” is any refrigerant in a system that has not had compressor burnout. If the system has experienced burnout, it is recommended that the existing line set and indoor coil be replaced.

NOTE

In lieu of R-410A, an industry-standard flushing agent may also be used.

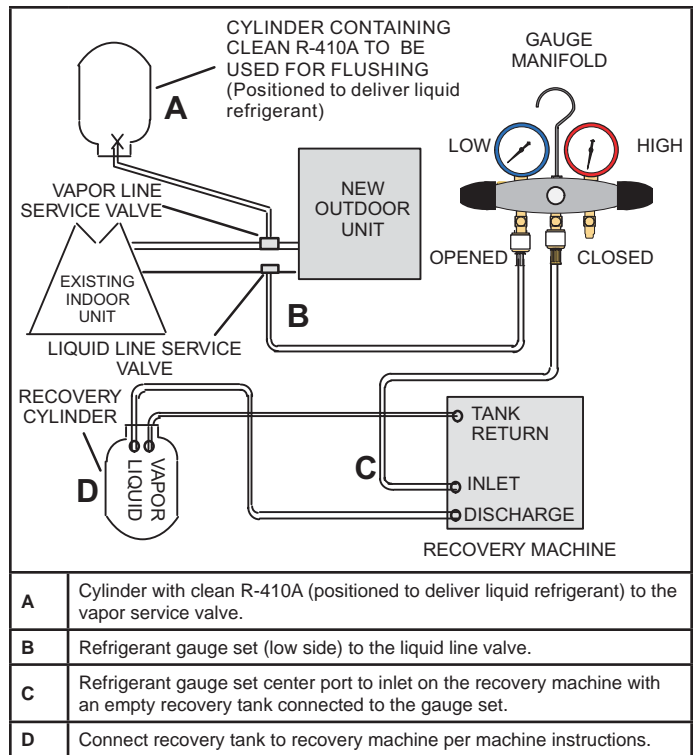

Figure 12.

1. Connect gauges and equipment as shown in Figure 12.
2. Set the recovery machine for liquid recovery and start the recovery machine. Open the gauge set valves to allow the recovery machine to pull a vacuum on the existing system line set and indoor unit coil.
3. Position the cylinder of clean R-410A for delivery of liquid refrigerant and open its valve to allow liquid refrigerant to flow into the system through the vapor line valve. Allow the refrigerant to pass from the cylinder and through the line set and the indoor unit coil before it enters the recovery machine.
4. After all of the liquid refrigerant has been recovered, switch the recovery machine to vapor recovery so that all of the R-410A vapor is recovered. Allow the recovery machine to pull the system down to 0.
5. Close the valve on the inverted R-410A drum and the gauge set valves. Pump the remaining refrigerant out of the recovery machine and turn the machine off.

Refrigerant Piping - Install Indoor Expansion Valve

This outdoor unit is designed for use in systems that include an expansion valve metering device (purchased separately) at the indoor coil. See the Product Specifications for approved expansion valve kit match-ups and application information. The check expansion valve unit can be installed internal or external to the indoor coil. In applications where an uncased coil is being installed in a field-provided plenum, install the check/expansion valve in a manner that will provide access for future field service of the expansion valve. Refer to below illustration for reference during installation of expansion valve unit.

INDOOR EXPANSION VALVE INSTALLATION

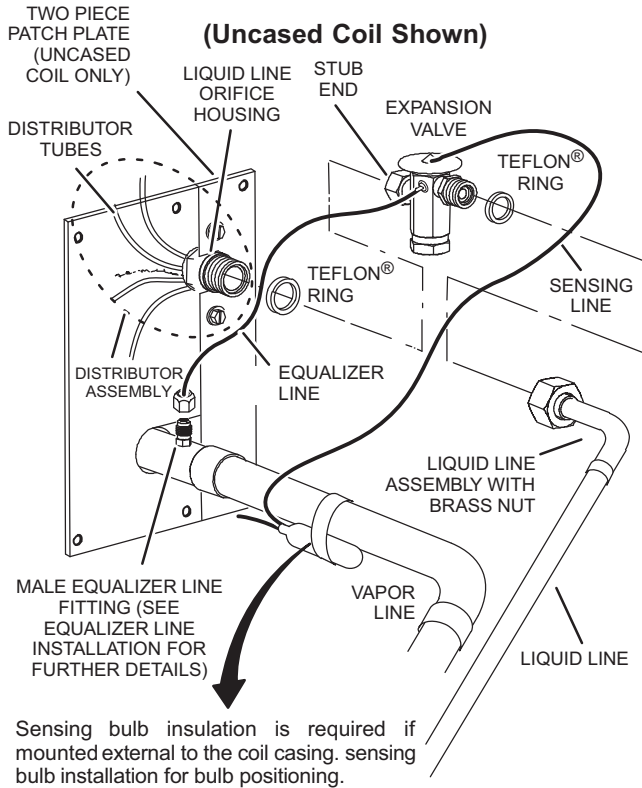

- 3 - Install one of the provided Teflon® rings around the stubbed end of the check expansion valve and lightly lubricate the connector threads and expose surface of the Teflon® ring with refrigerant oil.
- 4 - Attach the stubbed end of the check expansion valve to the liquid line orifice housing. Finger tighten and use an appropriately sized wrench to turn an additional 1/2 turn clockwise as illustrated in the figure above, or tighten to 20 ft-lb.
- 5 - Place the remaining Teflon® washer around the other end of the check expansion valve. Lightly lubricate connector threads and expose surface of the Teflon® ring with refrigerant oil.
- 6 - Attach the liquid line assembly to the check expansion valve. Finger tighten and use an appropriately sized wrench to turn an additional 1/2 turn clockwise as illustrated in the figure above or tighten to 20 ft-lb.

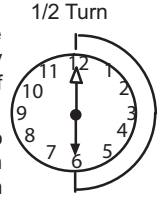

SENSING BULB INSTALLATION

- 1 - Attach the vapor line sensing bulb in the proper orientation as illustrated to the right using the clamp and screws provided.

NOTE - Though it is preferred to have the sensing bulb installed on a horizontal run of the vapor line, installation on a vertical run of piping is acceptable if necessary.

NOTE - Confirm proper thermal contact between vapor line and check/expansion bulb before insulating the sensing bulb once installed.

- 2 - Connect the equalizer line from the check expansion valve to the equalizer vapor port on the vapor line. Finger tighten the flare nut plus 1/8 turn (7 ft-lbs) as illustrated below.

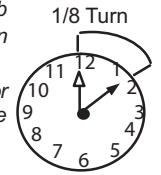

EQUALIZER LINE INSTALLATION

- 1 - Remove and discard either the flare seal cap or flare nut with copper flare seal bonnet from the equalizer line port on the vapor line as illustrated in the figure below.
- 2 - Remove the field-provided fitting that temporarily reconnected the liquid line to the indoor unit's distributor assembly.

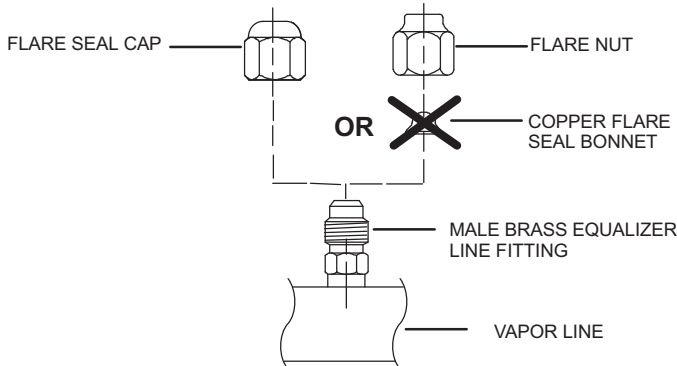

ON LINES SMALLER THAN 7/8", MOUNT SENSING BULB AT EITHER THE 3 OR 9 O'CLOCK POSITION.

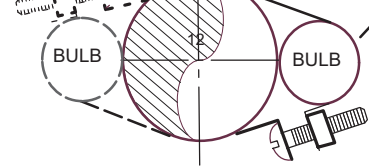

ON 7/8" AND LARGER LINES, MOUNT SENSING BULB AT EITHER THE 4 OR 8 O'CLOCK POSITION.

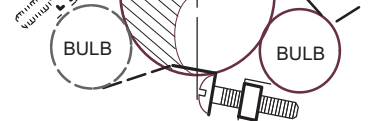

NOTE - NEVER MOUNT THE SENSING BULB ON BOTTOM OF LINE.

Refrigerant Piping - Brazing Procedures

1 CUT AND DEBUR

Cut ends of the refrigerant lines square (free from nicks or dents) and debur the ends. The pipe must remain round. Do not crimp end of the line.

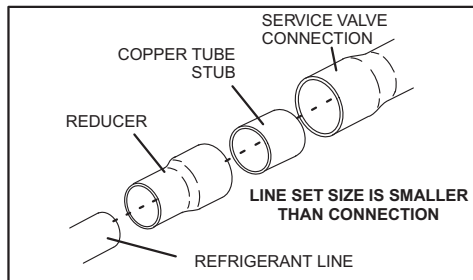
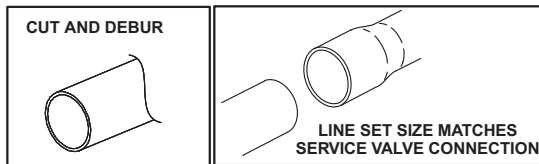

DO NOT CRIMP SERVICE VALVE CONNECTOR WHEN PIPE IS SMALLER THAN CONNECTION

2 CAP AND CORE REMOVAL

Remove service cap and core from both the vapor and liquid line service ports.

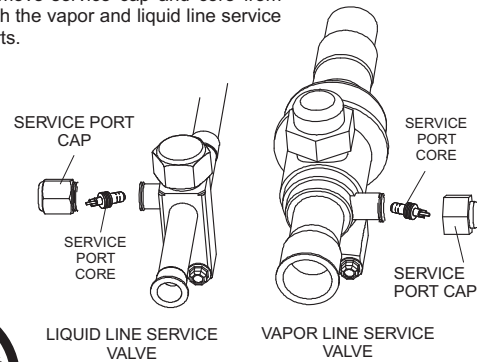

3 ATTACH THE MANIFOLD GAUGE SET FOR BRAZING LIQUID AND VAPOR LINE SERVICE VALVES

Flow regulated nitrogen (at 1 to 2 psig) through the low-side refrigeration gauge set into the liquid line service port valve, and out of the vapor line service port valve.

- A - Connect gauge set low pressure side to liquid line service valve (service port).
- B - Connect gauge set center port to bottle of nitrogen with regulator.
- C - Remove core from valve in vapor line service port to allow nitrogen to escape.

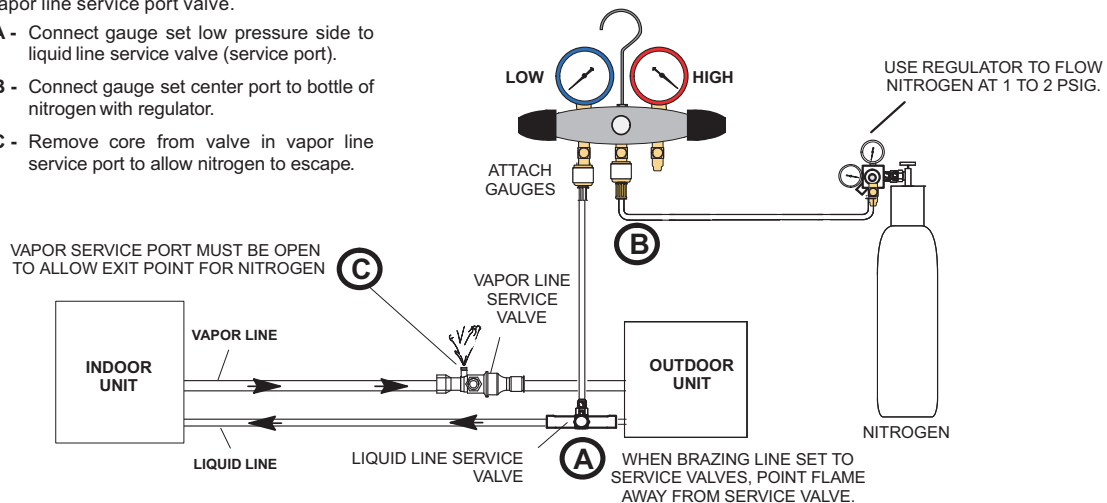

NOTE

Use a manifold gauge set designed for use on R-410A refrigerant systems.

⚠ WARNING

Brazing alloys and flux contain materials which are hazardous to your health.

Avoid breathing vapors or fumes from brazing operations. Perform operations only in well-ventilated areas.

Wear gloves and protective goggles or face shield to protect against burns.

Wash hands with soap and water after handling brazing alloys and flux.

⚠ WARNING



Before brazing, ensure the system is fully recovered of all refrigerant. Application of a brazing torch to a pressurized system may result in ignition of the refrigerant and oil mixture. Check the high and low pressures before applying heat.

4 WRAP SERVICE VALVES

To help protect service valve seals during brazing, wrap water-saturated cloths around service valve bodies and copper tube stubs. Use additional water-saturated cloths underneath the valve body to protect the base paint.

5 FLOW NITROGEN

Flow regulated nitrogen (at 1 to 2 psig) through the refrigeration gauge set into the valve stem port connection on the liquid service valve and out of the vapor valve stem port. See steps **3A**, **3B** and **3C** on manifold gauge set connections.

6 BRAZE LINE SET

Wrap both service valves with water-saturated cloths as illustrated here and as mentioned in step 4, before brazing to line set. Cloths must remain water-saturated throughout the brazing and cool-down process.

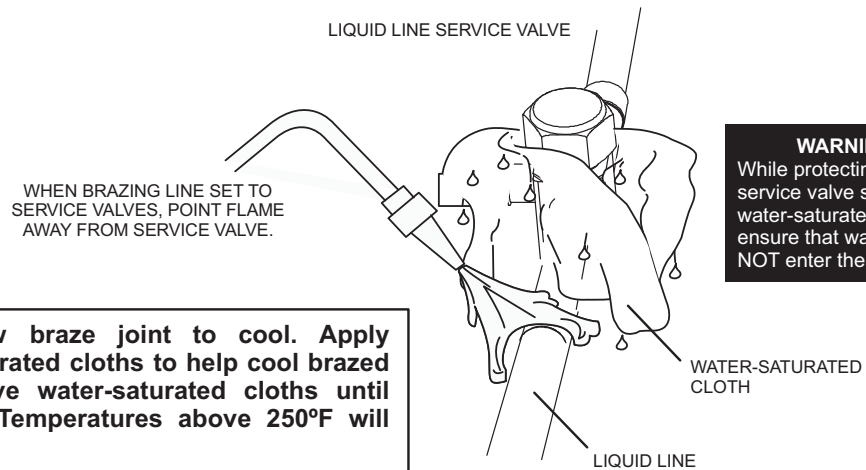

WARNING

FIRE, PERSONAL INJURY, OR PROPERTY DAMAGE may result if you do not wrap a water-saturated cloth around both liquid and suction line service valve bodies and copper tube stub while brazing the line set! The braze, when complete, must be quenched with water to absorb any residual heat.

Do not open service valves until refrigerant lines and indoor coil have been leak-tested and evacuated. Refer to Leak Test and Evacuation section of this manual.

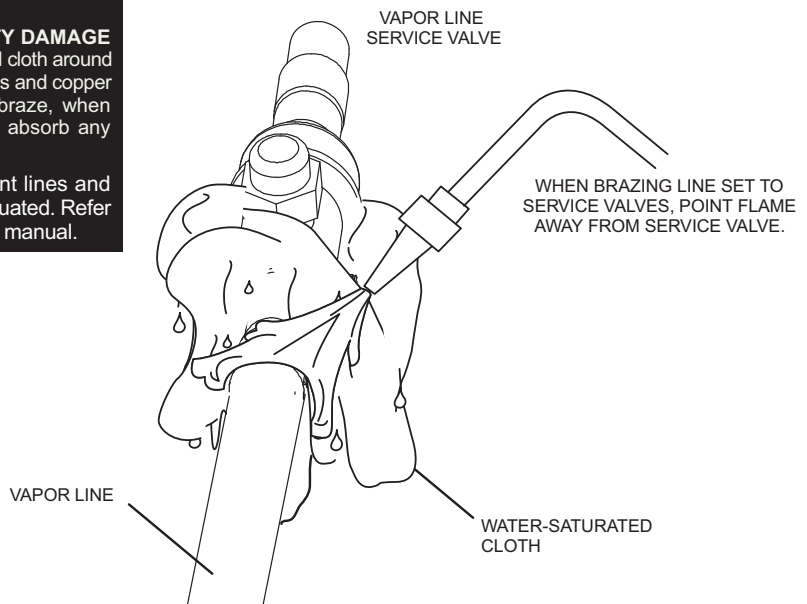

7 PREPARATION FOR NEXT STEP

After all connections have been brazed, disconnect manifold gauge set from service ports. Apply additional water-saturated cloths to both services valves to cool piping. Once piping is cool, remove all water-saturated cloths.

Leak Test and Evacuation

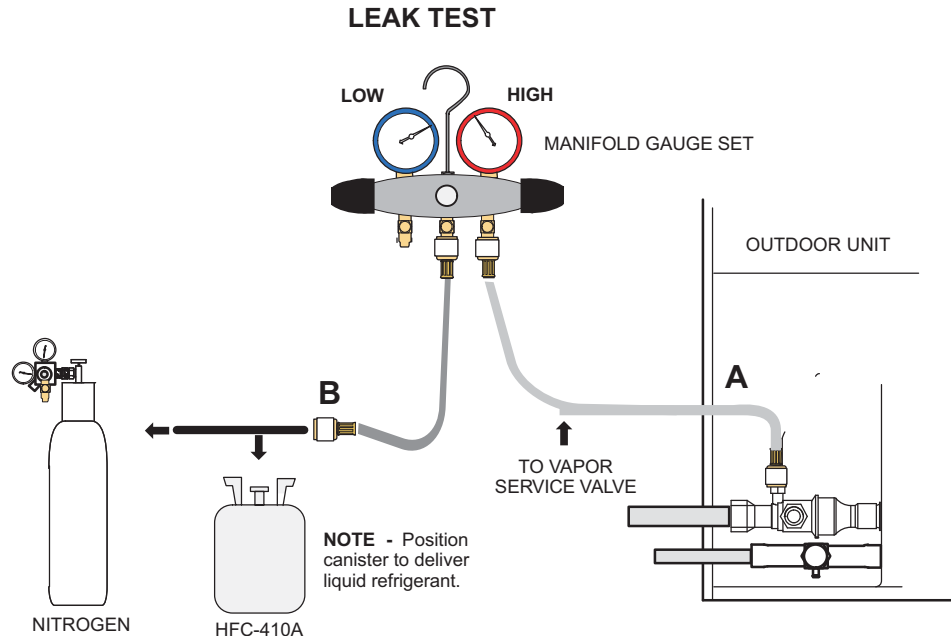

1 CONNECT GAUGE SET

- A** - Connect the high pressure hose of an HFC-410A manifold gauge set to the vapor valve service port.
NOTE - Normally, the high pressure hose is connected to the liquid line port. However, connecting it to the vapor port better protects the manifold gauge set from high pressure damage.
- B** - With both manifold valves closed, connect the cylinder of HFC-410A refrigerant to the center port of the manifold gauge set.
NOTE - Later in the procedure, the HFC-410A container will be replaced by the nitrogen container.

2 TEST FOR LEAKS

After the line set has been connected to the indoor and outdoor units, check the line set connections and indoor unit for leaks. Use the following procedure to test for leaks:

- A** - With both manifold valves closed, connect the cylinder of HFC-410A refrigerant to the center port of the manifold gauge set. Open the valve on the HFC-410A cylinder (vapor only).
- B** - Open the high pressure side of the manifold to allow HFC-410A into the line set and indoor unit. Weigh in a trace amount of HFC-410A. [A trace amount is a maximum of two ounces (57 g) refrigerant or three pounds (31 kPa) pressure.] Close the valve on the HFC-410A cylinder and the valve on the high pressure side of the manifold gauge set. Disconnect the HFC-410A cylinder.
- C** - Connect a cylinder of nitrogen with a pressure regulating valve to the center port of the manifold gauge set.
- D** - Adjust nitrogen pressure to 150 psig (1034 kPa). Open the valve on the high side of the manifold gauge set in order to pressurize the line set and the indoor unit.
- E** - After a few minutes, open one of the service valve ports and verify that the refrigerant added to the system earlier is measurable with a leak detector.
- F** - After leak testing, disconnect gauges from service ports.
NOTE - Service valve cores remain removed for the following evacuation procedure.

3 CONNECT GAUGE SET

NOTE - Remove cores from service valves (if not already done).

- A - Connect low side of manifold gauge set with 1/4 SAE in-line tee to vapor line service valve
- B - Connect high side of manifold gauge set to liquid line service valve
- C - Connect available micron gauge connector on the 1/4 SAE in-line tee.
- D - Connect the vacuum pump (with vacuum gauge) to the center port of the manifold gauge set. The center port line will be used later for both the HFC-410A and nitrogen containers.

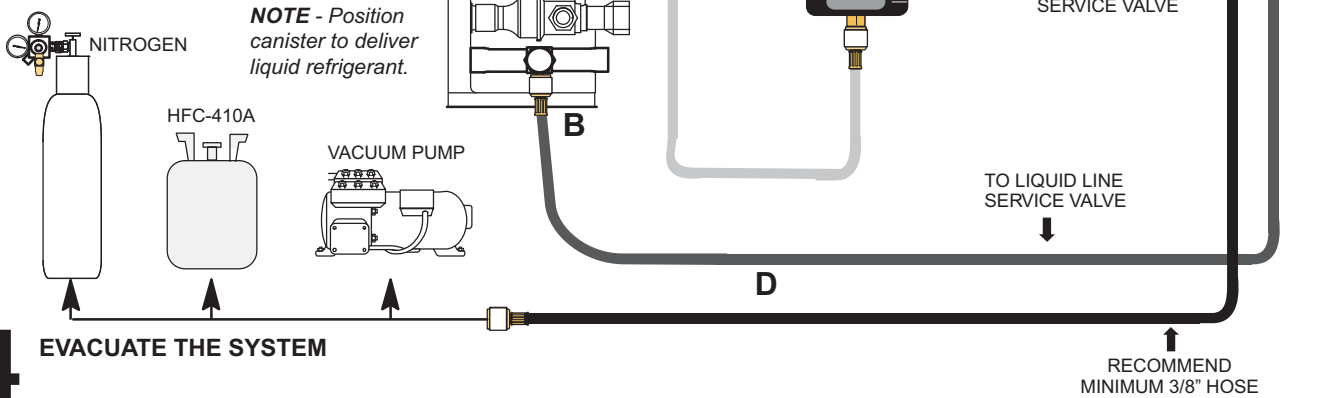

4 EVACUATE THE SYSTEM

- A - Open both manifold valves and start the vacuum pump.
- B - Evacuate the line set and indoor unit until a slight vacuum is indicated on the micron gauge (approximately 23,000 microns or 29.01 inches of mercury).
 - NOTE** - During the early stages of evacuation, it is desirable to close the manifold gauge valve at least once. A rapid rise in pressure indicates a relatively large leak. If this occurs, **repeat the leak testing procedure**.
 - NOTE** - The term **absolute pressure** means the total actual pressure above absolute zero within a given volume or system. Absolute pressure in a vacuum is equal to atmospheric pressure minus vacuum pressure.
- C - When the absolute pressure reaches 23,000 microns (29.01 inches of mercury), perform the following:
 - Close manifold gauge valves.
 - Close valve on vacuum pump.
 - Turn off vacuum pump.
 - Disconnect manifold gauge center port hose from vacuum pump.
 - Attach manifold center port hose to a nitrogen cylinder with pressure regulator set to 150 psig (1034 kPa) and purge the hose.
 - Open manifold gauge valves to break the vacuum in the line set and indoor unit.
 - Close manifold gauge valves.
- D - Shut off the nitrogen cylinder and remove the manifold gauge hose from the cylinder. Open the manifold gauge valves to release the nitrogen from the line set and indoor unit.
- E - Reconnect the manifold gauge to the vacuum pump, turn the pump on, and continue to evacuate the line set and indoor unit until the absolute pressure does not rise above 500 microns (29.9 inches of mercury) within a 20-minute period after shutting off the vacuum pump and closing the manifold gauge valves.
- F - When the absolute pressure requirement above has been met, disconnect the manifold hose from the vacuum pump and connect it to a cylinder of HFC-410A positioned to deliver liquid refrigerant. Open the manifold gauge valve 1 to 2 psig in order to release the vacuum in the line set and indoor unit.
- G - Perform the following:
 - Close manifold gauge valves.
 - Shut off HFC-410A cylinder.
 - Reinstall service valve cores by removing manifold hose from service valve. Quickly install cores with core tool while maintaining a positive system pressure.
 - Replace stem caps and finger tighten them, then tighten an additional one-sixth (1/6) of a turn as illustrated.
- H - Open suction service valve first before liquid valve to release the unit charge into the system. Replace valve caps and tighten (8 ft. lb.). Caps are the primary seal.

WARNING !

Possible equipment damage.

Avoid deep vacuum operation. Do not use compressors to evacuate a system. Extremely low vacuum can cause internal arcing and compressor failure. Damage caused by deep vacuum operation will void warranty.

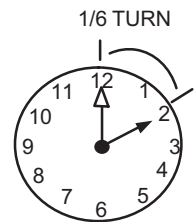

Electrical - Circuit Sizing and Wire Routing

In the U.S.A., wiring must conform with current local codes and the current National Electric Code (NEC). In Canada, wiring must conform with current local codes and the current Canadian Electrical Code (CEC).

Refer to the furnace or air handler installation instructions for additional wiring application diagrams and refer to unit nameplate for minimum circuit ampacity and maximum overcurrent protection size.

24VAC Transformer

Use the transformer provided with the furnace or air handler for low-voltage control power (24VAC - 40 VA minimum).

Thermostat Control and Low Voltage Control Wiring

The NS23AM variable capacity unit may be installed using a conventional 24VAC two-stage cooling or single-stage cooling thermostat.

NOTE: *The conventional 24VAC thermostat must have a compressor minimum on time of three minutes to prevent compressor short cycling.*

The NS23AM unit will provide full variable capacity operation when installed with a conventional 24VAC two-stage cooling or single-stage cooling thermostat. The NS23AM outdoor control has advanced control algorithms using the NS23AM suction pressure sensor to provide true variable capacity operation.

When utilizing a two-stage conventional 24VAC thermostat, four wires are required to control the outdoor unit (R, C, Y1 and Y2). Refer to the NS23AM field wiring diagram for a conventional 24VAC two-stage thermostat.

When utilizing a single-stage conventional 24VAC thermostat, three wires are required to control the outdoor unit (R, C, and Y1) and Y1 is jumpered to Y2 in the outdoor unit. Note that the published performance data is based upon the use of a two-stage thermostat. Refer to the NS23AM field wiring diagram for a conventional 24VAC single-stage thermostat.

NS23AM Low Voltage Control Wiring Connections

The NS23AM variable capacity units are provided with (2) RAST 6-Pin connections in the installation instruction bag for connecting the field low voltage control wiring to the NS23AM harnesses in the low voltage control make-up box. One RAST 6-pin connector is labeled with terminals TST, DF, R, I+, I- and C. The second RAST 6-pin connector is labeled with terminals DS, O, Y1, Y2, L and W.

WARNING

Electrical Shock Hazard!

Can cause injury or death. Unit must be properly grounded in accordance with national and local codes.



Line voltage is present at all components when unit is not in operation on units with single-pole contactors. Disconnect all remote electric power supplies before opening access panel. Unit may have multiple power supplies.

WARNING

ELECTROSTATIC DISCHARGE (ESD)

Precautions and Procedures

Electrostatic discharge can affect electronic components. Take care during unit installation and service to protect the unit's electronic controls. Precautions will help to avoid control exposure to electrostatic discharge by putting the unit, the control and the technician at the same electrostatic potential. Touch hand and all tools on an unpainted unit surface before performing any service procedure to neutralize electrostatic charge.

⚠ WARNING

Fire Hazard. Use of aluminum wire with this product may result in a fire, causing property damage, severe injury or death. Use copper wire only with this product.

⚠ WARNING

Failure to use properly sized wiring and circuit breaker may result in property damage. Size wiring and circuit breaker(s) per Technical Specifications and unit rating plate.

Thermostat Type	Indoor Unit Type	Qty. of Wires to Unit	NS23AM Terminal Strip Connections	Unit Operation	Field Wiring Diagram
Conventional 24VAC 2-Stage Cooling Thermostat	Any Furnace or Air Handler (non-communicating)	4	R, C, Y1, Y2	Full Variable Capacity Operation Controlled by NS23AM Unitary Control Using Suction Pressure	Figure 12
Conventional 24VAC Single-Stage Cooling Thermostat	Any Furnace or Air Handler (non-communicating)	3	R, C, Y1 (Jumper Y1 to Y2)	Full Variable Capacity Operation Controlled by NS23AM Unitary Control Using Suction Pressure	Figure 11

Table 7. Thermostat Control Options

Size Circuit and Install Service Disconnect Switch

Refer to the unit nameplate for minimum circuit ampacity, and maximum fuse or circuit breaker (HACR per NEC). Install power wiring and properly sized disconnect switch.

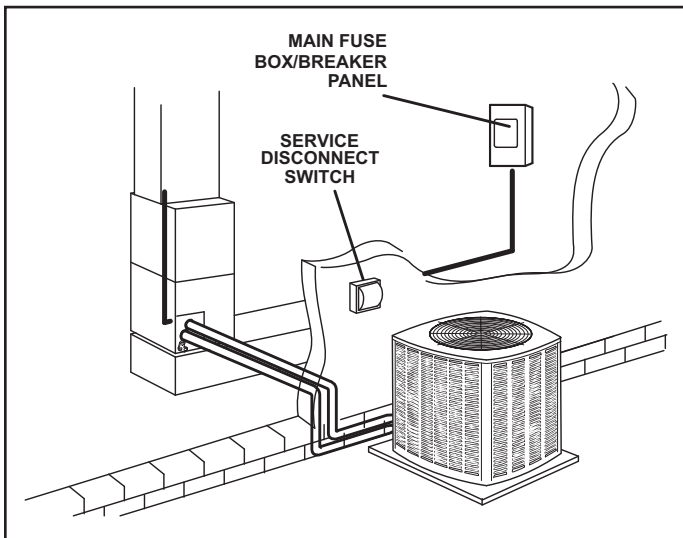

Figure 13.

NOTE: Units are approved for use only with copper conductors. Ground unit at disconnect switch or connect to an earth ground.

Install Thermostat

Install room thermostat (ordered separately) on an inside wall approximately in the center of the conditioned area and 5 feet (1.5m) from the floor. It should not be installed on an outside wall or where it can be affected by sunlight or drafts.

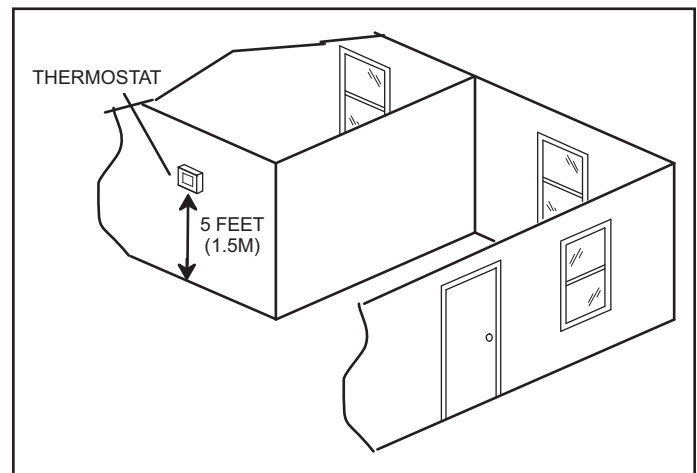

Figure 14.

NOTE: 24VAC, Class II circuit connections are made in the control panel.

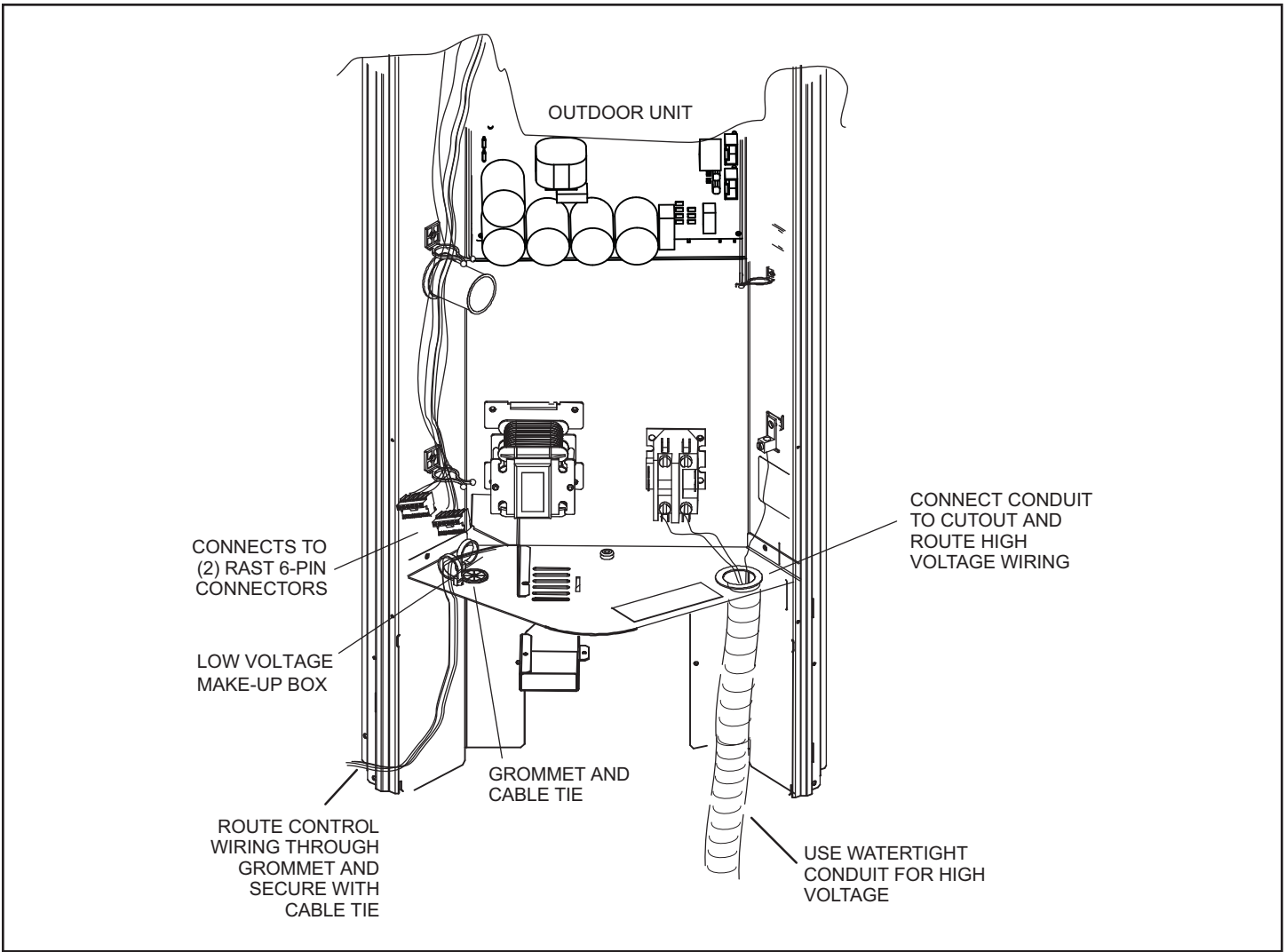

Figure 15.

Route Control Wires

Conventional 24VAC Thermostat Wiring

Wire Run Length	AWG#	Insulation Type
Less than 100' (30m)	18	Temperature Rating 35°C Minimum
More than 100' (30m)	16	

Table 8. Conventional 24VAC Thermostat Wiring

Route High Voltage and Ground Wires

Any excess high voltage field wiring should be trimmed and secured away from any low voltage field wiring. To facilitate a conduit, a cutout is located on the bottom of the control box. Connect conduit to the control box using a proper conduit fitting.

Connect the 208/230 high voltage power supply from the disconnect to the NS23AM contactor as shown. Connect the ground wire from the power supply to the unit ground lug connection.

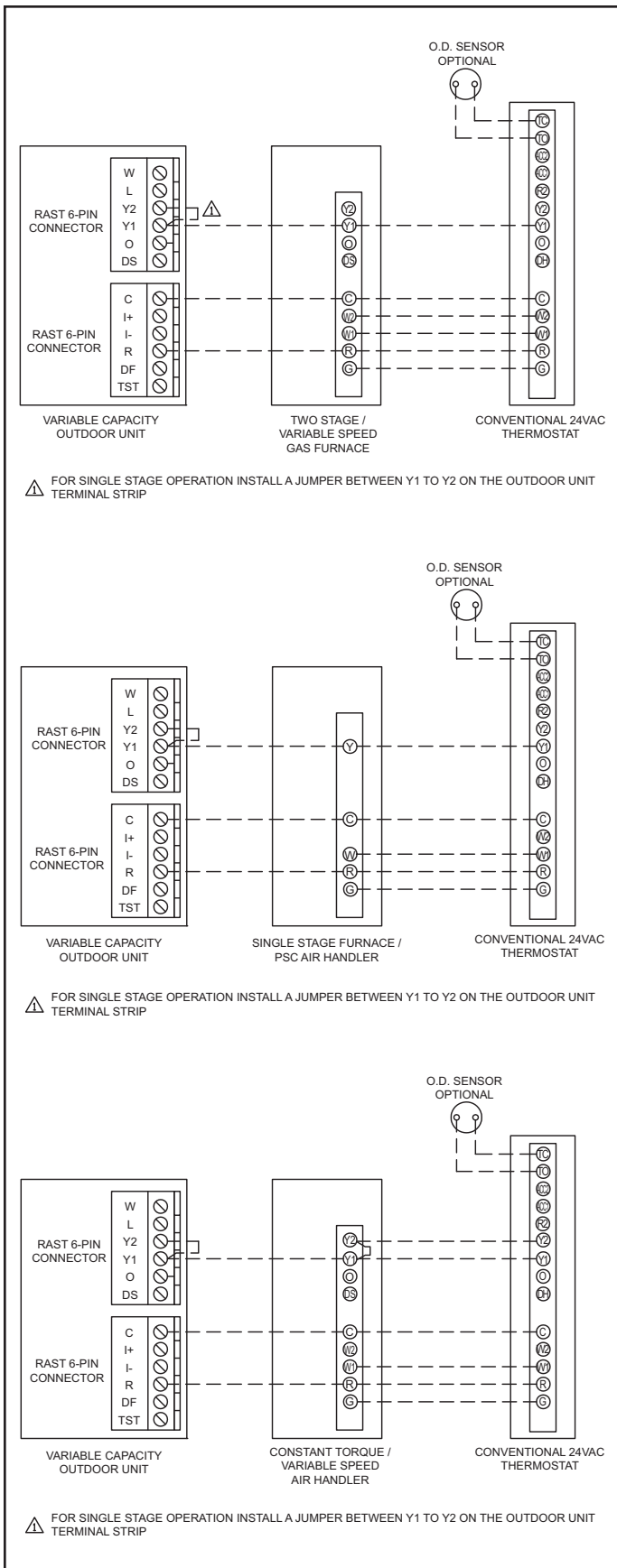

Figure 16. Conventional 24VAC Cooling Thermostat Wiring - Single Stage

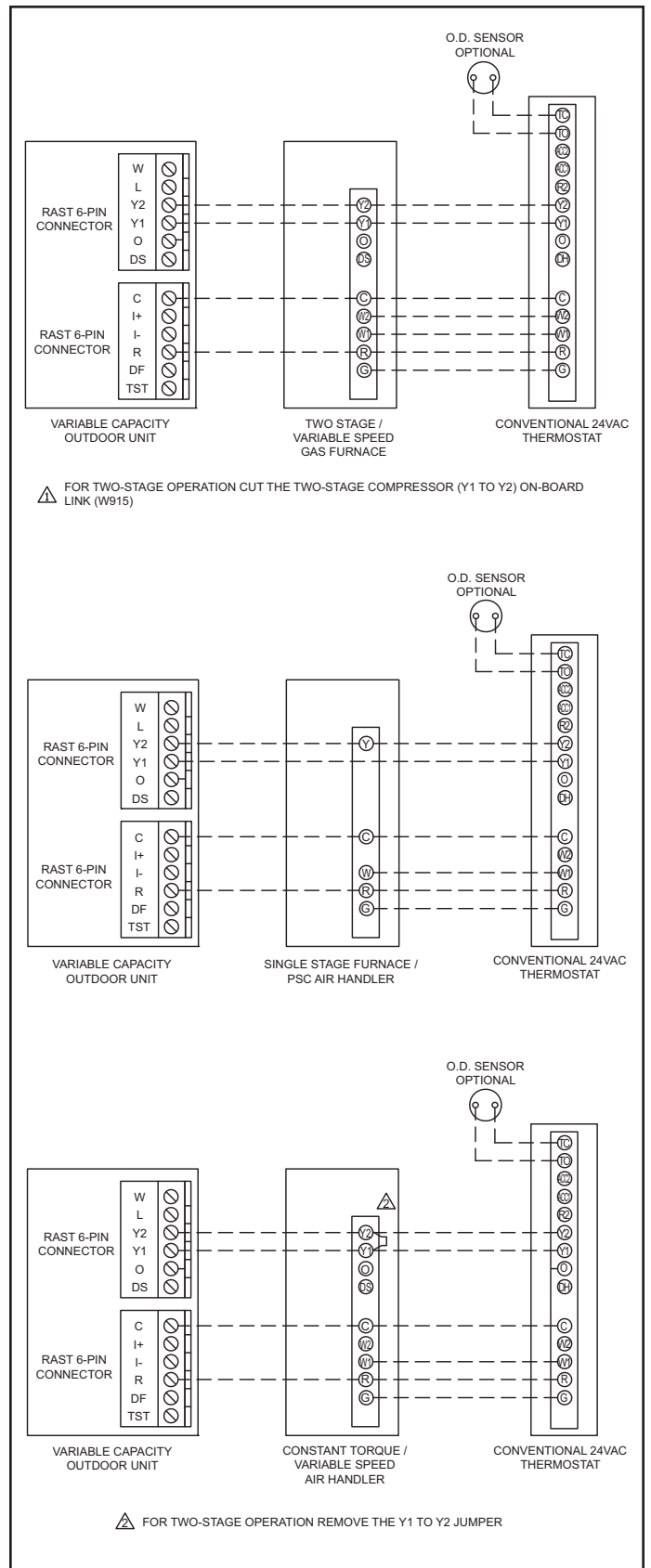

Figure 17. Conventional 24VAC Cooling Thermostat Wiring - Two Stage

Outdoor Unitary Control

Jumpers and Terminals

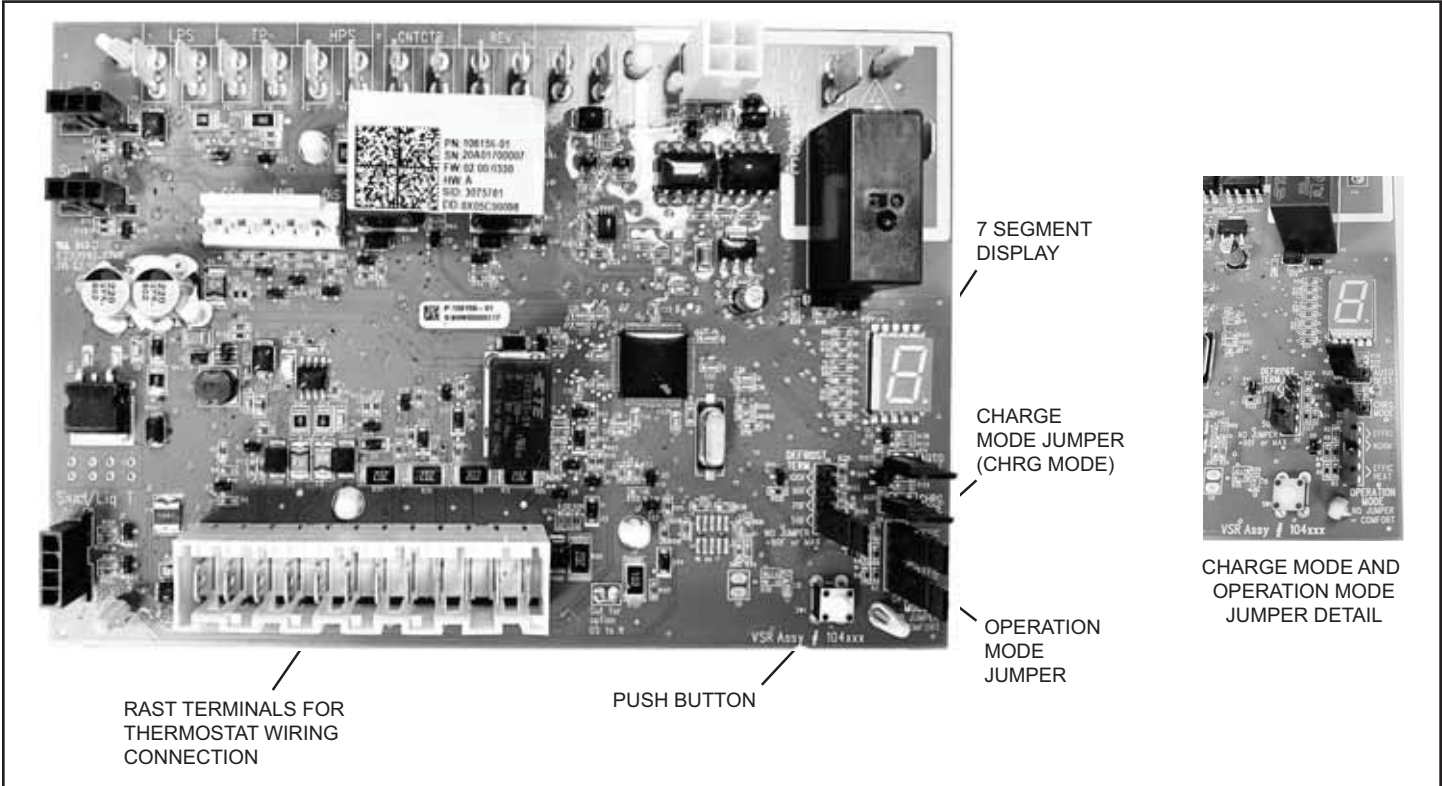

Figure 18.

7-Segment Display and Push Button

Information labels concerning the outdoor control 7-segment display and push button operations are available on the unit control panel cover.

Alarms

Alarm information is provided on the unit control panel cover.

Charge Mode Jumper

To initiate the NS23AM Charge Mode function, install the jumper across the two Charge Mode Pins (CHRG MODE) on the outdoor control. The Charge Mode can be used when charging the system with refrigerant, checking the refrigerant charge, pumping down the system and performing other service procedures that requires outdoor unit operation at 100% capacity.

NS23AM Charge Mode Operation with a Conventional 24VAC Thermostat

On applications with a conventional 24VAC thermostat, the charge mode jumper must be installed on the Charge Mode Pins after providing a Y1 cooling demand to the NS23AM to initiate the Charge Mode. A cooling blower demand must also be provided to initiate blower operation on the cooling speed on the indoor unit. The compressor and outdoor fan motor will operate at 100% capacity. To exit the charging mode, remove the Charge Mode Jumper and remove the Y1 Cooling demand and indoor blower demand. The Charge Mode has a maximum time of 60 minutes and will automatically exit the charge mode after 60 minutes is the charge mode jumper is left in place.

Operation Mode Jumper

The Operation Mode Jumper is only used on applications installed with a conventional 24VAC thermostat. In applications with a conventional 24VAC thermostat, the compressor capacity is controlled to maintain the target suction pressure setpoint. The Operation Mode Jumper has three selectable cooling modes. The three modes are Efficiency (Jumper installed on Pins 1 & 2), Normal Mode (Jumper installed on Pins 2 & 3) and Comfort Mode (Jumper Removed). The factory default position is the Efficiency Mode. The Efficiency mode has a variable suction pressure setpoint that will vary with the outdoor temperature; as the outdoor temperature increases the suction pressure setpoint will decrease. When the Operation Mode jumper is installed in the "Normal Mode" the suction pressure setpoint is 135 psig. When the Operation Mode jumper is installed in the "Comfort Mode" the suction pressure setpoint is 125 psig.

Unit Operation

NS23AM Unit Operation with a Conventional 24VAC 2-Stage Thermostat

When the NS23AM unit is installed with a conventional 24VAC 2-stage thermostat, a Y1 first stage cooling demand will initiate cooling operation and first stage indoor blower operation. The compressor will be controlled in the variable capacity mode by varying the compressor capacity to obtain the target suction pressure set point. The Y2 second stage cooling demand will initiate second stage blower operation. Increased air volume will increase the load on the indoor coil and increase the suction pressure. The NS23AM compressor capacity will continue to be controlled based upon the suction pressure. The unit capacity will be controlled in the variable capacity mode throughout the range of capacity from minimum capacity to maximum capacity. If the Y2 demand remains after 20 minutes, the NS23AM control will begin to ramp up the compressor capacity until maximum capacity is achieved. The NS23AM unit will cycle off once the thermostat demand is satisfied.

NS23AM Unit Operation with a Conventional 24VAC Single-Stage Thermostat

When the NS23AM unit is installed with a conventional 24VAC single-stage thermostat, a Y1 first stage cooling demand will initiate cooling operation and cooling indoor blower operation. In single stage thermostat applications, a jumper must be installed between Y1 and Y2 on the NS23AM outdoor control. The compressor will be controlled in the variable capacity mode by varying the compressor capacity to obtain the target suction pressure set point. If the cooling demand remains after 20 minutes, the NS23AM control will begin to ramp up the compressor capacity until maximum capacity is achieved. The NS23AM unit will cycle off once the thermostat demand is satisfied.

Designator	Description	Input	Output	Common
O	Unused on NS23AM, for heat pump applications only	N/A	Switched 24VAC nominal	N/A
REV	Unused on NS23AM, for heat pump applications only	N/A	N/A	24VAC common
LPS	Low pressure switch (not used on NS23AM)	N/A	5ma @ 18VAC	N/A
LPS	Low pressure switch sensing connection (not used on NS23AM)	5ma @ 18VAC	N/A	N/A
HPS	High pressure switch	N/A	24VAC nominal	N/A
HPS	High pressure switch sensing connection	24VAC nominal	N/A	N/A
TP	Top cap thermostat switch (in series with the HPS)	N/A	24VAC nominal	N/A
TP	Top cap thermostat switch sensing connection	24VAC nominal	N/A	N/A
Cntctr	Control (inverter power) contactor switched output (in series with the HPS and TC)	N/A	Switched 24VAC nominal	N/A
Cntctr	Contactor common	N/A		24VAC common
FPWM	PWM fan output	N/A	10-97% duty cycle, 19-23 VDC peak	
C	PWM fan common connection	N/A	N/A	Fan PWM common
P10 (PSC Fan 1/4" QC)	1/4" QC terminals - Switched output for PSC outdoor fan control	N/A	Switched 230VAC Nominal	N/A
RAST Connector Terminal Designations				
W	Unused; for heat pump applications only	N/A	24VAC nominal	N/A
L	24VAC input to initiate load shed	24VAC nominal from load shed N.O. contacts (close to initiate load shed)	N/A	N/A
Y2	Y2 second stage cooling input when a conventional 24VAC thermostat is used. Must be jumpered to Y1 if a single stage cooling thermostat is used	24VAC nominal from thermostat	N/A	N/A
Y1	Y1 first stage cooling input when a conventional 24VAC thermostat is used	24VAC nominal from thermostat	N/A	N/A
O	Unused on NS23AM, for heat pump applications only	24VAC nominal from thermostat	N/A	N/A
DS	Dehumidification input - not used	N/A	N/A	N/A
C	24VAC nominal power return	N/A	N/A	24VAC common
I-	Unused	Data	Data	N/A
I+	Unused	Data	Data	N/A
R	24VAC nominal power input	24VAC nominal board main power input	N/A	N/A
DF	OEM test	N/A	N/A	N/A
TST	OEM test pin	24VAC nominal	N/A	N/A

Table 9. Outdoor Control Terminal Designations and Inputs / Outputs

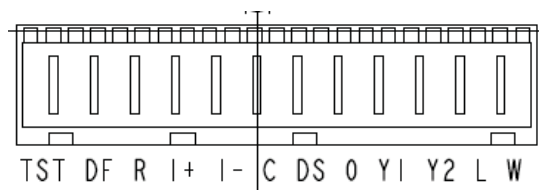

WARNING - Electric Shock Hazard. Can cause injury or death. Unit must be grounded in accordance with national and local codes. The 4 pins in P6 have the potential of transferring up to 250 volts to the unit cabinet ground.

Designator		Description	Input	Output	Common
P6 - Pin 1	Tx	Transmit data to inverter, connects to Rx of inverter	Outdoor control communication transmit pin	– Pin 1 to pin 2 should read 4.5 to 5.55 VDC when not communicating – Pin 3 to pin 2 should read 4.5 to 5.55 VDC when not communicating – Pin 4 to pin 2 should read 4.5 to 5.5 VDC NOTE - Communication signals switch off and on rapidly. This may cause volt meter readings to fluctuate. This is normal. Communication signals will switch between this 5V and common (Pin 2).	
P6 - Pin2	Inverter Common	Inverter common NOTE – This is a signal reference point and not an earth ground.	Inverter common		
P6 - Pin 3	Rx	Receive data from the inverter Connects to Tx of inverter	Outdoor control communication receive pin		
P6 - Pin 4	Inv 5V	Inverter 5VDC volts	Inverter 5VDC volts		
DIS		Discharge Line temperature sensor - not used (10K ohm resistor installed)	N/A	N/A	N/A
DIS		Discharge Line temperature sensor - not used (10K ohm resistor installed)	N/A	N/A	N/A
AMB		Outdoor ambient temperature sensor supply	N/A	N/A	N/A
AMB		Outdoor ambient temperature sensor return	N/A	N/A	N/A
COIL		Outdoor coil temperature sensor - not used (10K ohm resistor installed)	N/A	N/A	N/A
COIL		Outdoor coil temperature sensor - not used (10K ohm resistor installed)	N/A	N/A	N/A
CHRG MODE		<p>Charge Mode function. Can be used when charging, checking charge, pump down or checking unit operation. Unit will run at 100% capacity.</p> <p>Conventional 24VAC thermostat</p> <ol style="list-style-type: none"> 1. Install the Charge Mode jumper (before the Y1 demand) 2. Provide a Y1 demand to the NS23AM 3. A blower demand must be provided to the indoor unit for 100% of the cooling air volume. 4. Remove the charge mode jumper to end the charge mode <p>NOTE - If the charge mode jumper is in the ON position during power-up, it is ignored.</p> <p>NOTE - If the charge mode is left in place, it will be ignored after 60 minutes.</p>	<div style="display: flex; justify-content: space-around;"> <div style="text-align: center;"> <p>Charge Mode Disabled</p>  <p>CHRG MODE</p> </div> <div style="text-align: center;"> <p>Charge Mode Enabled</p>  <p>CHRG MODE</p> </div> </div>		

Table 10. Outdoor Control Terminal Designations and Inputs / Outputs

WARNING - Electric Shock Hazard. Can cause injury or death. Unit must be grounded in accordance with national and local codes. The 4 pins in P6 have the potential of transferring up to 250 volts to the unit cabinet ground.

Designator	Description	Input	Output	Common
Suction Pressure Out	Pressure transducer Supply Voltage Pin 1 of 3		5 VDC	
Suction Pressure In	Pressure transducer output voltage Pin 2 of 3	0-4.5 VDC		
Suction Pressure GND	Pressure transducer GND Pin 3 of 3			VDC Com
Liquid Pressure Out	Pressure transducer Supply Voltage Pin 1 of 3		5 VDC	
Liquid Pressure In	Pressure transducer Supply Voltage Pin 2 of 3	0-4.5 VDC		
Liquid Pressure GND	Pressure transducer GND Pin 3 of 3			VDC Com
SUCT1	Suction Line Temperature Sensor Supply - Pin 1 of 4		0-4.5 VDC	
SUCT2	Suction Line Temperature Sensor Supply - Pin 2 of 4			
LIQ1	Liquid Line Temperature Sensor Supply - Pin 3 of 4		0-4.5 VDC	
LIQ2	Liquid Line Temperature Sensor Supply - Pin 4 of 4			

Table 10. Outdoor Control Terminal Designations and Inputs / Outputs

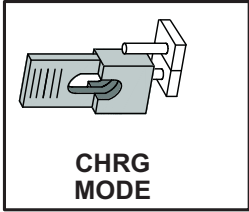
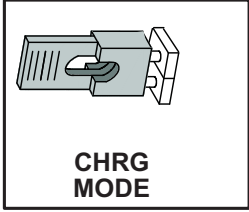
Servicing Units Delivered Void of Charge

If the outdoor unit is void of refrigerant, clean the system using the procedure described below.

1. Leak test the system using the procedure outlined on page 21.
2. Evacuate the system using procedure outlined on page 21.
3. Use nitrogen to break the vacuum and install a new filter drier in the system.
4. Evacuate the system again using procedure outlined on page 21.
5. Weigh in refrigerant using procedure outlined in Figure 50.
6. Monitor the system to determine the amount of moisture remaining in the oil. It may be necessary to replace the filter drier several times to achieve the required dryness level. **If system dryness is not verified, the compressor will fail in the future.**

Start-Up

CAUTION

If unit is equipped with a crankcase heater, it should be energized 24 hours before unit start-up to prevent compressor damage as a result of slugging.

1. Rotate fan to check for frozen bearings or binding.
2. Inspect all factory and field-installed wiring for loose connections.
3. After evacuation is complete, open liquid line and suction line service valves to release refrigerant charge (contained in outdoor unit) into system.
4. Replace the stem caps and secure finger tight, then tighten an additional 1/6 of a turn.
5. Check voltage supply at the disconnect switch. The voltage must be within the range listed on the unit nameplate. If not, do not start equipment until the power company has been consulted and the voltage condition corrected.
6. Set the thermostat for a cooling demand. Turn on power to the indoor indoor unit and close the outdoor unit disconnect switch to start the unit.
7. Recheck voltage while the unit is running. Power must be within range shown on the unit nameplate.
8. Check system for sufficient refrigerant using the procedures outlined under Checking Refrigerant Charge.

System Operation and Service

7-Segment Alert and System Status Codes

Alert codes are displayed using the 7-segment display located on the outdoor control.

NOTE: *System fault and lockout codes take precedence over system status codes (cooling, heating operating percentages or defrost/dehumidification).*

The 7-segment will display an abnormal condition (error code) when detected in the system. A list of the codes are shown in .

Resetting Alert Codes

Alert codes can be reset manually or automatically:

Manual Reset

Manual reset can be achieved by one of the following methods:

1. Disconnecting R wire from the outdoor control R terminal.
2. Turning the indoor unit off and back on again
3. After power up, all currently displayed codes are cleared.

Automatic Reset

After an alert is detected, the outdoor control continues to monitor the unit's system and compressor operations. When/if conditions return to normal, the alert code is turned off automatically.

NOTE: *Error codes can be recalled by following information shown in Table 12 on Table 12.*

NOTE: System fault and lockout codes take precedence over system status codes (cooling, heating operating percentages or defrost/dehumidification). Only the latest active fault or lockout codes are displayed (if present). If no fault or lockout codes are active, then system status codes are displayed.

GF= Gas Furnace, AH=Air Handler, ID=Indoor unit (GF or AH), HP=Heat Pump, AC=Air Conditioner, OD=Outdoor Unit (AC or HP), ZA=Zone system and TS=Thermostat

Alert Code	Inverter Code	Inverter Flash Code		Priority Condition	Actual Displayed Alert Text	Component or System Operational State and Troubleshooting Tip	How to Clear Alert Code
		Red LED	Green LED				
N/A	N/A	ON	OFF	N/A	24, 36 only: Indicates inverter is operating normally.		
N/A	N/A	ON	ON	N/A	48, 60 only: Indicates inverter is operating normally.		
N/A	N/A	OFF	OFF	N/A	Indicates inverter is NOT energized.		

Table 11. Alert Codes and Troubleshooting

NOTE: System fault and lockout codes take precedence over system status codes (cooling, heating operating percentages or defrost/dehumidification). Only the latest active fault or lockout codes are displayed (if present). If no fault or lockout codes are active, then system status codes are displayed.

GF= Gas Furnace, AH=Air Handler, ID=Indoor unit (GF or AH), HP=Heat Pump, AC=Air Conditioner, OD=Outdoor Unit (AC or HP), ZA=Zone system and TS=Thermostat

Alert Code	Inverter Code	Inverter Flash Code		Priority Condition	Actual Displayed Alert Text	Component or System Operational State and Troubleshooting Tip	How to Clear Alert Code
		Red LED	Green LED				
120		N/A	N/A	Service Soon	Unresponsive Device	<p>There is a delay in the system component responding to the system. Typically this alert code does not cause any operational issues and will clear on its own.</p> <ul style="list-style-type: none"> This alert code is usually caused by a delay in the outdoor unit responding to the thermostat. Leaking voltage from strands within the bundle. <ul style="list-style-type: none"> > Land only the R wire on the R terminal to load the bundle with 24VAC. <ul style="list-style-type: none"> ▶ Typically only the R wire needs to be landed to identify if voltage is leaking. ▶ If voltage is present checking the other wires is informational only but not needed. ▶ If voltage is not present checking the other wires one at a time would be needed. > Check each loose wire in AC mode to C on circuit board. <ul style="list-style-type: none"> ▶ Good voltage is .03 -.3VAC leaking voltage is not the issue. ▶ Acceptable can be up to .7VAC with moderate success. ▶ Some units have worked with up to 1.2VAC with occasional success. ▶ Voltage over 1.2VAC needs to be addressed. 	Automatically clears after an unresponsive system component (device) responds to any inquiry.
125				Service Urgent	Control Hardware Problem	<p>There is a hardware problem on a system component control. There is a control hardware problem. Replace the control if the problem prevents operation and is persistent.</p>	Automatically clears five minutes after the issue no longer exists.
132				Service Urgent	Device Control Software Fault	<p>System component control software is corrupted.</p> <ul style="list-style-type: none"> Recycle power. If failure re-occurs, replace the system component control. 	Manual system power reset is required to recover from this alert code.
180				Service Soon	Outdoor Temperature Sensor Problem	<p>The thermostat has found a problem with the outdoor sensor in the outdoor unit or the optional outdoor sensor connected to the indoor unit. In normal operation after system component control recognizes sensors, the alert code will be sent if valid temperature reading is lost.</p> <ul style="list-style-type: none"> Compare outdoor sensor resistance to temperature / resistance charts in unit installation instructions. Replace sensor pack or stand alone outdoor sensor. At the beginning of (any) configuration, furnace, air-handler control or equipment interface module will detect the presence of the sensor(s). If detected (reading in range), appropriate feature will be set as 'installed' and shown in the 'About' screen. 	Automatically clears upon configuration, or sensing normal values.
181				Service Soon	OD Suction Pressure Transducer Fault	<ul style="list-style-type: none"> Suction Pressure Transducer reading above 4.75V or below 0.25V for 24hrs +/- 3hrs. Run on staged operation. 	Resets after 3 consecutive readings that are in range.
182				Service Soon	OD Suction Temperature Sensor Fault	<ul style="list-style-type: none"> Reading below 0.25V or above 4.75V for 24hrs +/- 3hrs. System will continue to operate normally. 	Resets after 3 consecutive readings that are in range.
183				Service Soon	OD Liquid Pressure Sensor Fault	<ul style="list-style-type: none"> Under 0.25V and above 4.75V readings for 24 hours +/-3hrs or more on the sensor will cause this error. Continue normal operation, see sections related to low pressure switch emulation for specific details related to low pressure switch faults. 	Resets after 3 consecutive readings that are in range.

Table 11. Alert Codes and Troubleshooting

NOTE: System fault and lockout codes take precedence over system status codes (cooling, heating operating percentages or defrost/dehumidification). Only the latest active fault or lockout codes are displayed (if present). If no fault or lockout codes are active, then system status codes are displayed.

GF= Gas Furnace, AH=Air Handler, ID=Indoor unit (GF or AH), HP=Heat Pump, AC=Air Conditioner, OD=Outdoor Unit (AC or HP), ZA=Zone system and TS=Thermostat

Alert Code	Inverter Code	Inverter Flash Code		Priority Condition	Actual Displayed Alert Text	Component or System Operational State and Troubleshooting Tip	How to Clear Alert Code
		Red LED	Green LED				
345				Service Urgent	Relay O Failure	The O relay on the system component has failed. Either the pilot relay contacts did not close or the relay coil did not energize. <ul style="list-style-type: none"> Possible O relay / stage 1 failure. Pilot relay contacts did not close or the relay coil did not energize. Replace system component (device) control. If error is applicable to any GEA variable capacity outdoor unit, the outdoor control will need to be replaced.	Automatically clears after the fault recovered following reset.
409				Service Soon	OD Control Board Low 24VAC	The secondary voltage for the applicable system component has fallen below 18VAC. This may be due to: <ul style="list-style-type: none"> Secondary voltage is below 18VAC. If this continues for 10 minutes, the thermostat will turn off the applicable system component. 	Automatically clears after voltage is detected as higher than 20VAC for two seconds or after power reset.
410				Information Only-Dealer	OD Open Low Pressure Switch	Unit low pressure is below the required limit. <ul style="list-style-type: none"> Check operating pressures. Low pressure switch opens at a specific pressure (system shuts down) and closes at a specific pressure (system restarts). 	Automatically clears when the system detects that the issue no longer exists.
411				Service Urgent	OD Low Pressure Switch Strikes Lockout	The low pressure switch has opened five times during one cooling or heating demand. <ul style="list-style-type: none"> Thermostat will shut down the outdoor unit. Open low pressure switch error count reached five strikes. Check system charge using both approach and sub-cooling methods. Reset by putting outdoor unit control in test mode or resetting low voltage power. 	Automatically clears when the system detects that the issue no longer exists.
412				Information Only-Dealer	OD Open High Pressure Switch	The unit high pressure is above the upper limit. <ul style="list-style-type: none"> System will shut down. Confirm that the system is properly charged with refrigerant. Check condenser fan motor, expansion valve (if installed), indoor unit blower motor, stuck reversing valve or clogged refrigerant filter. Confirm that the outdoor unit is clean. 	Automatically clears after the high pressure switch closes or a power reset.
413				Service Urgent	OD High Pressure Switch Strikes Lockout	The high pressure switch has opened five times during one cooling demand. <ul style="list-style-type: none"> Thermostat will shut down the outdoor unit. Open high pressure switch error count reached five strikes. Check system charge using superheat and sub-cooling temperatures. Check outdoor fan operation. Check for dirt or debris blocking air flow to outdoor unit. Reset by putting outdoor unit control in test mode or resetting low voltage power. 	Automatically clears when the system detects that the issue no longer exists.
416				Service Soon	OD Coil Sensor Faulty	The outdoor coil sensor is either open, short-circuited or the temperature is out of sensor range. <ul style="list-style-type: none"> Outdoor unit control will not perform demand or time / temperature defrost operation. (System will still heat or cool.) This fault is detected by allowing the unit to run for 90 seconds before checking sensor resistance. If the sensor resistance is not within range after 90 seconds, the control will display a moderate code. Advances from moderate to critical after ten (10) minutes. Plug-in sensor harness correctly. Check resistance of sensor to determine if it is open, shorted, out of temperature calibration or out of ambient temperature range. Replace if out-of-specifications. 	Automatically clears when outdoor unit control detects proper sensor readings. If sensor is faulty and the system is reporting the condition as critical, replaced sensor. Reset power to clear alert code.

Table 11. Alert Codes and Troubleshooting

NOTE: System fault and lockout codes take precedence over system status codes (cooling, heating operating percentages or defrost/dehumidification). Only the latest active fault or lockout codes are displayed (if present). If no fault or lockout codes are active, then system status codes are displayed.

GF= Gas Furnace, AH=Air Handler, ID=Indoor unit (GF or AH), HP=Heat Pump, AC=Air Conditioner, OD=Outdoor Unit (AC or HP), ZA=Zone system and TS=Thermostat

Alert Code	Inverter Code	Inverter Flash Code		Priority Condition	Actual Displayed Alert Text	Component or System Operational State and Troubleshooting Tip	How to Clear Alert Code
		Red LED	Green LED				
422				Service Soon	OD Compressor Top Cap Switch Open	Compressor top cap switch exceeding thermal limit. <ul style="list-style-type: none"> Check condenser fan motor, TXV and indoor unit blower motor. Check for stuck reversing valve or clogged refrigerant filter. Check to ensure that one of the wires from the top cap switch has not been disconnected from one of the TP terminals on the outdoor control. Reconnect wire if disconnected. Check superheat and sub-cooling. 	Automatically clears when error is corrected.
423	40	4 flashes	OFF	Service Soon/ Service Urgent	OD Inverter CT Circuit Fault	The inverter has detected a circuit issue. <ul style="list-style-type: none"> When this condition is detected the outdoor control will stop outdoor unit operations and start the anti-short cycle timer – moderate condition. Outdoor control will lockout unit after 10 strikes within an hour – critical condition. Inverter LEDs will flash code 40 Refer to the unit service documentation for troubleshooting procedures. <p>Inverter flash code 40:</p> <p>The sequence is: Red LED: Four Flashes Green LED: Off</p> <p>NOTE: Inverter normal operations with no error code present is as follows. Red LED is ON and Green LED is OFF.</p>	A moderate alert code will clear automatically when the inverter detects the condition no longer exist and will send a clear alert code message. To clear critical alert code disconnect power to outdoor unit and restart.
424				Service Soon	OD Liquid Line Sensor Faulty	The liquid line temperature sensor has malfunctioned. <ul style="list-style-type: none"> In normal operation after outdoor control recognizes sensors, the alert code will be sent if a valid temperature reading is lost. Compare liquid line sensor resistance to temperature / resistance charts in unit installation instructions. Replace sensor pack if necessary. At the beginning of (any) configuration, furnace or air handler control will detect the presence of the sensor(s). If detected (reading in range), appropriate feature will be set as 'installed' and shown in the thermostat 'About' screen. 	Automatically clears upon configuration, or sensing normal values.
426				Service Urgent	OD Excessive Inverter Alarms	After 10 faults within 60 consecutive minutes, the control will lockout. Inverter will flash codes 12 to 14 and 53. NOTE: These inverter codes do not count towards this lockout condition.	To clear disconnect power to outdoor control and restart.

Table 11. Alert Codes and Troubleshooting

NOTE: System fault and lockout codes take precedence over system status codes (cooling, heating operating percentages or defrost/dehumidification). Only the latest active fault or lockout codes are displayed (if present). If no fault or lockout codes are active, then system status codes are displayed.

GF= Gas Furnace, AH=Air Handler, ID=Indoor unit (GF or AH), HP=Heat Pump, AC=Air Conditioner, OD=Outdoor Unit (AC or HP), ZA=Zone system and TS=Thermostat

Alert Code	Inverter Code	Inverter Flash Code		Priority Condition	Actual Displayed Alert Text	Component or System Operational State and Troubleshooting Tip	How to Clear Alert Code
		Red LED	Green LED				
427	21	2 flashes	1 flash	Service Soon/Service Urgent	OD Inverter DC Peak Fault	<p>The inverter has detected a DC peak fault condition.</p> <ul style="list-style-type: none"> If condition (55A or higher) is detected, outdoor unit will stop (compressor and fan) – moderate condition. Anti-short cycle is initiated. If peak current (55A or higher) occurs 10 times within an hour, system will lockout – critical condition. Inverter LEDs will flash code 21. If the unit is a variable capacity heat pump, this error may occur entering or exiting a defrost cycle as the compressor restarts after the 30 second compressor shift delay. If the unit was manufactured prior to serial number 5817F and has frequent alert code 427, then compare the inverter part number to the latest part number listed in the unit repair parts. Units produced after serial number 5817F which is listed on the unit name plate have an inverter with updated software that includes compressor current slope logic to reduce the potential of alert code 427 instances from occurring during defrost. Replace the inverter with the latest inverter if necessary. Refer to the unit service documentation for detailed troubleshooting procedures. <p>NOTE: Serial number format on unit name plate is PPYYMNNNNN (PP = Manufacturing Plant, YY and M represents the year and month made).</p> <p>Inverter flash code 21.</p> <p>The sequence is:</p> <ul style="list-style-type: none"> Red LED: Two Flashes Green LED: One Flash <p>NOTE: Inverter normal operations with no error code present is as follows. Red LED is ON and Green LED is OFF.</p>	To clear, disconnect and reconnect power to outdoor control.
428	22	2 flashes	2 flashes	Service Soon/Service Urgent	OD Inverter High Main Input Current	<p>The inverter has detected a high main input current condition.</p> <ul style="list-style-type: none"> If condition is detected, outdoor unit will stop (compressor and fan) – moderate condition. Anti-short cycle is initiated. If condition occurs 10 times within an hour, system will lockout – critical condition. Inverter LEDs will flash code 22. Refer to the unit service documentation for detailed troubleshooting procedures. <p>Inverter flash code 22.</p> <p>The sequence is:</p> <ul style="list-style-type: none"> Red LED: Two Flashes Green LED: Two Flashes <p>NOTE: Inverter normal operations with no error code present is as follows. Red LED is ON and Green LED is OFF.</p>	To clear, disconnect power to outdoor unit and restart.

Table 11. Alert Codes and Troubleshooting

NOTE: System fault and lockout codes take precedence over system status codes (cooling, heating operating percentages or defrost/dehumidification). Only the latest active fault or lockout codes are displayed (if present). If no fault or lockout codes are active, then system status codes are displayed.

GF= Gas Furnace, AH=Air Handler, ID=Indoor unit (GF or AH), HP=Heat Pump, AC=Air Conditioner, OD=Outdoor Unit (AC or HP), ZA=Zone system and TS=Thermostat

Alert Code	Inverter Code	Inverter Flash Code		Priority Condition	Actual Displayed Alert Text	Component or System Operational State and Troubleshooting Tip	How to Clear Alert Code
		Red LED	Green LED				
429	23	2 flashes	3 flashes	Service Soon/ Service Urgent	OD Inverter DC Link Low Voltage	<p>The inverter has detected a DC link low voltage condition.</p> <ul style="list-style-type: none"> On a call for compressor operation, if DC link power in inverter does not rise above 180 VDC for 2- and 3-ton models, 250 VDC for 4- and 5-ton models within 30 seconds, the control will display a moderate code. If condition is detected, outdoor unit will stop (compressor and fan) – moderate condition. An anti-short cycle timer is initiated. If condition occurs 10 times within a 60 consecutive minutes, system will lock out and display alert code 429 – critical condition. The outdoor control anti-short cycle timer will time out and the unit will recycle the demand. Inverter LEDs will flash code 23. Refer to the unit service documentation for detailed troubleshooting procedures. Perform test function and verify inverter DC link and line input voltage and current. Also check input to filter board and reactor before replacing inverter board. <p>Inverter flash code 23.</p> <p>The sequence is:</p> <ul style="list-style-type: none"> Red LED: Two Flashes Green LED: Three Flashes <p>NOTE: Inverter normal operations with no error code present is as follows. Red LED is ON and Green LED is OFF.</p> <p>Troubleshooting Suggestions:</p> <ul style="list-style-type: none"> Check wire connections (U, V and W) at inverter plug in harness and compressor. Check the resistance of compressor windings. If not in range, replace compressor. Check compressor to ground. If ground issue, replace compressor. Check input power (Single Phase - 208/230VAC ± 10%. If out of range, correct main power issue. Check DC Link voltage and MICOM Sensing voltage. If out of range, replace inverter. if okay, possible mechanical issue with compressor. <p>Go to outdoor unit service manual for detail troubleshooting procedures and require values for testing DC link voltages and various insulation resistance characteristics.</p>	Automatically clears when the system detects that the issue no longer exists.
430	26	2 flashes	6 flashes	Service Soon/ Service Urgent	OD Inverter Compressor Startup Fail	<p>Compressor start-up failure.</p> <ul style="list-style-type: none"> If condition is detected, outdoor unit will stop (compressor and fan) – moderate condition. Anti-short cycle is initiated. If condition occurs 10 times within 60 consecutive minutes, the system will lockout – critical condition. Inverter LEDs will flash code 26. Refer to the unit service documentation for detailed troubleshooting procedures. <p>Inverter flash code 26.</p> <p>The sequence is:</p> <ul style="list-style-type: none"> Red LED: Two Flashes Green LED: Six Flashes <p>NOTE: Inverter normal operations with no error code present is as follows. Red LED is ON and Green LED is OFF.</p> <ul style="list-style-type: none"> Check refrigerant Replace outdoor control board Replace inverter. 	To clear, disconnect power to outdoor unit and restart.

Table 11. Alert Codes and Troubleshooting

NOTE: System fault and lockout codes take precedence over system status codes (cooling, heating operating percentages or defrost/dehumidification). Only the latest active fault or lockout codes are displayed (if present). If no fault or lockout codes are active, then system status codes are displayed.

GF= Gas Furnace, AH=Air Handler, ID=Indoor unit (GF or AH), HP=Heat Pump, AC=Air Conditioner, OD=Outdoor Unit (AC or HP), ZA=Zone system and TS=Thermostat

Alert Code	Inverter Code	Inverter Flash Code		Priority Condition	Actual Displayed Alert Text	Component or System Operational State and Troubleshooting Tip	How to Clear Alert Code
		Red LED	Green LED				
431	27	2 flashes	7 flashes	Service Soon/ Service Urgent	OD Inverter PFC Fault	<p>The inverter has detected a PFC circuit over-current condition.</p> <ul style="list-style-type: none"> • Error occurs when PFC detects an over current condition of 100A peak. • If condition is detected, outdoor unit will stop (compressor and fan) – moderate condition. • Anti-short cycle timer is initiated. • If condition occurs 10 times within 60 consecutive minutes, the system will lockout – critical condition. • Inverter LEDs will flash code 27. • Refer to the unit service documentation for detailed troubleshooting procedures. <p>Inverter flash code 27.</p> <p>The sequence is:</p> <ul style="list-style-type: none"> • Red LED: Two Flashes • Green LED: Seven Flashes <p>NOTE: Inverter normal operations with no error code present is as follows. Red LED is ON and Green LED is OFF.</p>	To clear, disconnect power to outdoor unit and restart.
432	28	2 flashes	8 flashes	Service Soon/ Service Urgent	OD Inverter DC Link High Voltage	<p>The inverter has detected a DC link high voltage condition.</p> <ul style="list-style-type: none"> • Error occurs when the DC link capacitor voltage is greater than 480 VDC. • If condition is detected, outdoor unit will stop (compressor and fan) – moderate condition. • Anti-short cycle timer is initiated. • If condition occurs 10 times within 60 consecutive minutes, the system will lockout – critical condition. • Inverter LEDs will flash code 28. • Refer to the unit service documentation for detailed troubleshooting procedures. <p>Inverter flash code 28.,</p> <p>The sequence is:</p> <ul style="list-style-type: none"> • Red LED: Two Flashes • Green LED: Eight Flashes <p>NOTE: Inverter normal operations with no error code present is as follows. Red LED is ON and Green LED is OFF.</p> <p>Troubleshooting Suggestions:</p> <ul style="list-style-type: none"> • Check wire connections (U, V and W) at inverter plug in harness and compressor. • Check the resistance of compressor windings. If not in range, replace compressor. • Check compressor to ground. If ground issue, replace compressor. • Check input power (Single Phase - 208/230VAC ± 10%. If out of range, correct main power issue. • Check DC Link voltage and MICOM Sensing voltage. If out of range, replace inverter. if okay, possible mechanical issue with compressor. <p>Go to outdoor unit service manual for detail troubleshooting procedures and require values for testing DC link voltages and various insulation resistance characteristics.</p>	To clear, disconnect power to outdoor unit and restart.

Table 11. Alert Codes and Troubleshooting

NOTE: System fault and lockout codes take precedence over system status codes (cooling, heating operating percentages or defrost/dehumidification). Only the latest active fault or lockout codes are displayed (if present). If no fault or lockout codes are active, then system status codes are displayed.

GF= Gas Furnace, AH=Air Handler, ID=Indoor unit (GF or AH), HP=Heat Pump, AC=Air Conditioner, OD=Outdoor Unit (AC or HP), ZA=Zone system and TS=Thermostat

Alert Code	Inverter Code	Inverter Flash Code		Priority Condition	Actual Displayed Alert Text	Component or System Operational State and Troubleshooting Tip	How to Clear Alert Code
		Red LED	Green LED				
433	29	2 flashes	9 flashes	Service Soon/ Service Urgent	OD Inverter Compressor Over-current	<p>Compressor phase current is too high.</p> <ul style="list-style-type: none"> • During initial startup, a six minute time delay is implement to prevent the alarm from occurring. • Error occurs when compressor peak phase current is greater than 28 amps. • Inverter will issue inverter code 14 first and slow down to try to reduce the current. • If the current remains high, outdoor unit will stop (compressor and fan) – moderate condition. • Cycle timer is initiated. • If condition occurs five times within 60 consecutive minutes, the system will lockout – critical condition. • This alert code may be triggered by the inverter or the GEA variable capacity outdoor (inverter controlled) unit. • Outdoor control may trigger an this alert code if the inverter reduces the compressor speed which is identified as a alert code 441 and the compressor speed (in hz) is below the minimum speed. This will typically occur at start-up. The inverter automatically increases the compressor minimum speed below 45°F in the heating mode and above 115°F ensure the compressor capacity is sufficient for oil return. • Inverter LEDs will flash code 29. • Refer to the unit service documentation for detailed troubleshooting procedures. <p>Inverter flash code 29.</p> <p>The sequence is:</p> <ul style="list-style-type: none"> • Red LED: Two Flashes • Green LED: Nine Flashes <p>NOTE: Inverter normal operations with no error code present is as follows. Red LED is ON and Green LED is OFF.</p>	To clear alert code disconnect power to both the indoor and outdoor units and then reconnect power. Restart system.

Table 11. Alert Codes and Troubleshooting

NOTE: System fault and lockout codes take precedence over system status codes (cooling, heating operating percentages or defrost/dehumidification). Only the latest active fault or lockout codes are displayed (if present). If no fault or lockout codes are active, then system status codes are displayed.

GF= Gas Furnace, AH=Air Handler, ID=Indoor unit (GF or AH), HP=Heat Pump, AC=Air Conditioner, OD=Outdoor Unit (AC or HP), ZA=Zone system and TS=Thermostat

Alert Code	Inverter Code	Inverter Flash Code		Priority Condition	Actual Displayed Alert Text	Component or System Operational State and Troubleshooting Tip	How to Clear Alert Code
		Red LED	Green LED				
434	53	5 flashes	3 flashes	Service Soon/Service Urgent	OD Inverter Comm Error to Main Control	<ul style="list-style-type: none"> Outdoor control has lost communications with the inverter continuously during a single thermostat call and one hour period. Outdoor control will stop all compressor demands – moderate condition. Indoor blower will stop functioning. <p>NOTE: Indoor blower will not run in test mode either when alert code 434 is active. Only after system reset will it operate.</p> <ul style="list-style-type: none"> This alert code will occur if the outdoor unit power is turned off and the indoor unit power (24VAC to outdoor control) remains on, or if the indoor unit power is turned off (24VAC to outdoor control) and the outdoor unit power is on. This could occur while performing service or maintenance procedures on the indoor or outdoor unit. The outdoor control will attempt to re-establish communication to the inverter when the alert code 434 occurs by cycling the outdoor unit contactor off for two minutes. Upon energizing the contactor the outdoor control will attempt to communicate to the inverter for three minutes. This process will be repeated three times in attempt to establish communication before locking out. If the unit is locked out with a critical alert code 434, reset the system by cycling the outdoor unit power off and back on. Then cycle the indoor power off (24VAC to the outdoor control) and then back on. If this condition continuously occurs during a one hour period and during a single thermostat call, the outdoor unit will lock out and display alert code 434 – critical condition. <p>Troubleshooting Options:</p> <ul style="list-style-type: none"> Check for loose or disconnected electrical connections. Interruption of main power to inverter. Inverter LEDs will flash code 53. Refer to the unit service documentation for detailed troubleshooting procedures. <p>Inverter flash code 53.</p> <p>The sequence is:</p> <ul style="list-style-type: none"> Red LED: Five Flashes Green LED: Three Flashes <p>NOTE: Inverter normal operations with no error code present is as follows. Red LED is ON and Green LED is OFF</p>	<p>Automatically clears when the system detects that the issue no longer exists.</p> <p>If the unit is locked out with a critical alert code 434, reset the system by first cycling the outdoor unit power off and back. Then cycle the indoor power off (24VAC to the outdoor control) and then back on.</p>
435	60	6 flashes	OFF	Service Urgent	OD Inverter EEPROM Checksum fault	<p>Inverter internal error.</p> <ul style="list-style-type: none"> When this error occurs, the outdoor control will cycle power to the inverter by opening the contactor for two minutes – moderate condition. Outdoor control will cycle power to the inverter three times and then outdoor unit is locked out – critical condition. Inverter LEDs will flash code 60. Refer to the unit service documentation for detailed troubleshooting procedures. <p>Inverter flash code 60.</p> <p>The sequence is:</p> <ul style="list-style-type: none"> Red LED: Six Flashes Green LED: Off <p>NOTE: Inverter normal operations with no error code present is as follows. Red LED is ON and Green LED is OFF.</p>	To clear alert code disconnect power to outdoor unit and restart.

Table 11. Alert Codes and Troubleshooting

NOTE: System fault and lockout codes take precedence over system status codes (cooling, heating operating percentages or defrost/dehumidification). Only the latest active fault or lockout codes are displayed (if present). If no fault or lockout codes are active, then system status codes are displayed.

GF= Gas Furnace, AH=Air Handler, ID=Indoor unit (GF or AH), HP=Heat Pump, AC=Air Conditioner, OD=Outdoor Unit (AC or HP), ZA=Zone system and TS=Thermostat

Alert Code	Inverter Code	Inverter Flash Code		Priority Condition	Actual Displayed Alert Text	Component or System Operational State and Troubleshooting Tip	How to Clear Alert Code
		Red LED	Green LED				
436	62	6 flashes	2 flashes	Service Soon/ Service Urgent	OD Inverter High Heat-Sink Temperature	<p>Inverter heat sink temperature exceeded limit.</p> <ul style="list-style-type: none"> This occurs when the heat sink temperature exceeds the inverter limit. Inverter will issue inverter alert code 13 first and slow down to try to cool the heat sink. If temperature remains high, outdoor unit will stop both compressor and fan – moderate condition. Anti-short cycle is initiated. If condition occurs five times within an hour, system will lockout – critical condition. The screws that hold the inverter to the inverter board were loose causing poor contact between these two components. Tighten screws that hold the heat sink to the inverter control board. <p>NOTE: Wait five minutes for all capacitors to discharge before checking screws.</p> <ul style="list-style-type: none"> Inverter LEDs will flash code 62. Refer to the unit service documentation for detailed troubleshooting procedures. <p>Inverter flash code 62.</p> <p>The sequence is:</p> <ul style="list-style-type: none"> Red LED: Six Flashes Green LED: Two Flashes <p>NOTE: Inverter normal operations with no error code present is as follows. Red LED is ON and Green LED is OFF.</p>	<p>Moderate condition will automatically clear when the inverter sends an alert code clear message.</p> <p>Critical condition is cleared by disconnecting power to the outdoor unit and restart.</p>
437	65	6 flashes	5 flashes	Service Soon/ Service Urgent	OD Inverter Heat-Sink temp Sensor Fault	<p>Heat sink temperature sensor fault has occurred (temperature less than 4°F or greater than 264°F after 10 minutes of operation).</p> <ul style="list-style-type: none"> When the temperature sensor detects a temperature less than 4°F or greater than 264°F after 10 minutes of operation. Outdoor unit will stop both compressor and fan – moderate condition. Anti-short cycle is initiated. If condition occurs five times within an hour, system will lockout – critical condition. Inverter LEDs will flash code 65. Refer to the unit service documentation for detailed troubleshooting procedures. <p>Inverter flash code 65.</p> <p>The sequence is:</p> <ul style="list-style-type: none"> Red LED: Six Flashes Green LED: Five Flashes <p>NOTE: Inverter normal operations with no error code present is as follows. Red LED is ON and Green LED is OFF.</p>	<p>Moderate priority condition will automatically clear when the inverter sends an alert code clear message.</p> <p>Critical priority condition can be cleared by disconnecting and reconnecting power to outdoor unit to restart.</p>

Table 11. Alert Codes and Troubleshooting

NOTE: System fault and lockout codes take precedence over system status codes (cooling, heating operating percentages or defrost/dehumidification). Only the latest active fault or lockout codes are displayed (if present). If no fault or lockout codes are active, then system status codes are displayed.

GF= Gas Furnace, AH=Air Handler, ID=Indoor unit (GF or AH), HP=Heat Pump, AC=Air Conditioner, OD=Outdoor Unit (AC or HP), ZA=Zone system and TS=Thermostat

Alert Code	Inverter Code	Inverter Flash Code		Priority Condition	Actual Displayed Alert Text	Component or System Operational State and Troubleshooting Tip	How to Clear Alert Code
		Red LED	Green LED				
438	73	7 flashes	3 flashes	Service Urgent	OD Inverter PFC Input Over-current	<p>The inverter has detected a power factor correction (PFC) circuit over-current condition.</p> <ul style="list-style-type: none"> The inverter has detected an PFC over current condition. This may be caused by a high load condition, high pressure, or outdoor fan failure. Outdoor control will display the code when the inverter has detected the error – moderate condition. After three minutes, the inverter will reset and the compressor will resume operation. If the error condition occurs 10 times within a 60 minute rolling time period, the outdoor unit control will lock out operation of the outdoor unit – critical condition. Possible issue is system running at high pressures. Check for high pressure trips or other alert codes in thermostat and outdoor control. Inverter LEDs will flash code 73. Refer to the unit service documentation for detailed troubleshooting procedures. <p>Inverter flash code 73.</p> <p>The sequence is:</p> <ul style="list-style-type: none"> Red LED: Seven Flashes Green LED: Three Flashes <p>NOTE: Inverter normal operations with no error code present is as follows. Red LED is ON and Green LED is OFF.</p>	<p>Moderate priority condition is automatically cleared when the inverter sends a clear message.</p> <p>Critical priority condition will automatically clear when inverter is power cycled.</p>

Table 11. Alert Codes and Troubleshooting

NOTE: System fault and lockout codes take precedence over system status codes (cooling, heating operating percentages or defrost/dehumidification). Only the latest active fault or lockout codes are displayed (if present). If no fault or lockout codes are active, then system status codes are displayed.

GF= Gas Furnace, AH=Air Handler, ID=Indoor unit (GF or AH), HP=Heat Pump, AC=Air Conditioner, OD=Outdoor Unit (AC or HP), ZA=Zone system and TS=Thermostat

Alert Code	Inverter Code	Inverter Flash Code		Priority Condition	Actual Displayed Alert Text	Component or System Operational State and Troubleshooting Tip	How to Clear Alert Code
		Red LED	Green LED				
440	13	1 flash	3 flashes	Information Only-Dealer	<p>OD Inverter Compressor Slowdown - High Heat-Sink temperature</p>	<p>Compressor slowdown due to high heat sink temperature.</p> <ul style="list-style-type: none"> Heat sink temperature is approaching limit. The compressor speed automatically slows to reduce heat sink temperature. The control sets indoor CFM and outdoor RPM to values according to demand percentage rather than the actual Hz. The screws that hold the inverter to the inverter board may be loose causing poor contact between these two components. Tighten screws that hold the heat sink to the inverter control board. <p>NOTE: Wait five minutes for all capacitors to discharge before checking screws.</p> <ul style="list-style-type: none"> This error code is primarily for informational purposes as the inverter controls the compressor speed to operate within design parameters. Typically the inverter will make a minor speed reduction of 4 Hz (approximately a 5-6% speed reduction) for a brief period of time and to reduce the heat sink temperature and will then resume normal operation. This may occur at high outdoor temperatures (above 110°F) for brief periods of time (3 – 4 minutes) and is normal and expected operation of the inverter controlling the compressor safely within design parameters. The inverter finned aluminum heat sink is located on the back side of the inverter in the condenser air stream. If the alert code 440 occur frequently, especially at lower outdoor temperatures, check the heat sink for debris that may reduce heat transfer or possible obstructions that may impact air flow across the heat sink. The inverter will begin to briefly reduce the compressor speed when the heat sink temperature rises above 185°F and will allow the inverter to resume the requested compressor demand speed once the inverter heat sink reaches 176°F. The heat sink temperature, compressor speed in Hertz & the Inverter Compressor Speed Reduction status ("On" or "Off ") notification can be viewed under the outdoor unit Diagnostics section of the thermostat dealer control center. Inverter LEDs will flash code 13. Refer to the unit service documentation for detailed troubleshooting procedures. <p>Inverter flash code 13.</p> <p>The sequence is:</p> <ul style="list-style-type: none"> Red LED: One Flash Green LED: Three Flashes <p>NOTE: Inverter normal operations with no error code present is as follows. Red LED is ON and green LED is OFF.</p>	<p>Automatically clears when the condition no longer exists.</p>

Table 11. Alert Codes and Troubleshooting

NOTE: System fault and lockout codes take precedence over system status codes (cooling, heating operating percentages or defrost/dehumidification). Only the latest active fault or lockout codes are displayed (if present). If no fault or lockout codes are active, then system status codes are displayed.

GF= Gas Furnace, AH=Air Handler, ID=Indoor unit (GF or AH), HP=Heat Pump, AC=Air Conditioner, OD=Outdoor Unit (AC or HP), ZA=Zone system and TS=Thermostat

Alert Code	Inverter Code	Inverter Flash Code		Priority Condition	Actual Displayed Alert Text	Component or System Operational State and Troubleshooting Tip	How to Clear Alert Code
		Red LED	Green LED				
441	14	1 flash	4 flashes	Information Only-Dealer	OD Inverter Compressor Slowdown - High Compressor Current	<p>This alert code is for more information than an issue with the system.</p> <ul style="list-style-type: none"> When the inverter gets close to the current or heat sink temperature limit, it will limit the ramp rate. Instead of changing compressor speed at 1 hz/second, it changes to 5 hz/20 seconds. Compressor slowdown due to high compressor current. Compressor current is approaching limit. The compressor speed automatically slows. This error code is primarily for informational purposes as the inverter controls the compressor to operate within design parameters. Alert code 441 typically occurs at startup as the compressor current increases rapidly during startup. The inverter will reduce the compressor speed by 4 Hz and slow the compressor ramp up speed to the requested compressor demand speed (capacity). This is normal and expected operation of the inverter to control the inverter within design parameters. In most cases the alert code 441 notification does not require any additional service or diagnostic procedures. The control sets indoor CFM and outdoor RPM to values according to demand percentage rather than the actual Hz. Possible issue is system running at high pressures. Check for high pressure trips or other alert codes in thermostat and outdoor control. Inverter LEDs will flash code 14. Refer to the unit service documentation for detailed troubleshooting procedures. <p>Inverter flash code 14.</p> <p>The sequence is:</p> <ul style="list-style-type: none"> Red LED: One Flash Green LED: Four Flashes <p>NOTE: Inverter normal operations with no error code present is as follows. Red LED is ON and green LED is OFF.</p>	Automatically clears when the condition no longer exists.
442				Service Urgent	OD Compressor Top Cap Switch Strikes Lockout	<p>The top cap switch has opened five times within one hour. As a result, the outdoor unit is locked out.</p> <ul style="list-style-type: none"> This condition occurs when compressor thermal protection sensor opens five times within one hour. Outdoor unit will stop. 	To clear, disconnect power to outdoor unit and restart.
443				Service Urgent	OD MUC Unit Code To Inverter Model Mismatch	<p>The GEA variable capacity unitary control (outdoor control) has incorrect appliance unit size code selected.</p> <ul style="list-style-type: none"> Check for proper configuring under unit size code used for outdoor unit (see unit configuration guide or in installation instructions). If replacing inverter, verify inverter model matches unit size. Remove the thermostat from the system while applying power and reprogramming. 	Automatically clears after the correct match is detected following a power reset.
600				Information Only-Dealer	Load Shed Event	<p>Compressor has been cycled OFF on utility load shedding.</p> <ul style="list-style-type: none"> Load shedding function provides a method for a local utility company to limit the maximum power level usage of the outdoor unit. The feature is activated by applying 24VAC power across the L and C terminals on the outdoor control 	Automatically clears when L terminal is inactive.
601				Information Only-Dealer	OD Unit Low Ambient Operational Lockout	<ul style="list-style-type: none"> Outdoor unit has been cycled off on low temperature protection. Outdoor unit will not operate when the outdoor ambient is at or below 4°F (-15.6°C). If the unit is satisfying a demand (running) and the outdoor ambient drops below 4°F (-15.6°C), the unit will continue to operate until the demand has been satisfied or the outdoor ambient drops to 15°F (-9.4°C) which will result in the unit being locked out (shut down). 	Automatically clears when low temperature condition no longer exists.

Table 11. Alert Codes and Troubleshooting

POWER-UP / RESET:

FIRMWARE VERSION: During initial power-up or reset, the first item displayed is the outdoor control firmware version. Example to the right shows firmware version 2.3.

UNIT TYPE: The next item displayed is the self discovery unit type. AC = air conditioner and HP = heat pump. If the unit type cannot be determined, three bars appear.

UNIT NOMINAL CAPACITY: The next item to be displayed is the self-discovery unit nominal capacity. Valid capacities are 24 for 2-ton, 36 for 3-ton, 48 for 4-ton and 60 for 5-ton units. If the unit type cannot be determined, three bars appear.

UNIT CODE: The next item to be displayed is the self discovery unit code. (may be a single character or two characters). If the unit code cannot be determined, three bars appear.

7-SEGMENT POWER-UP DISPLAY STRING

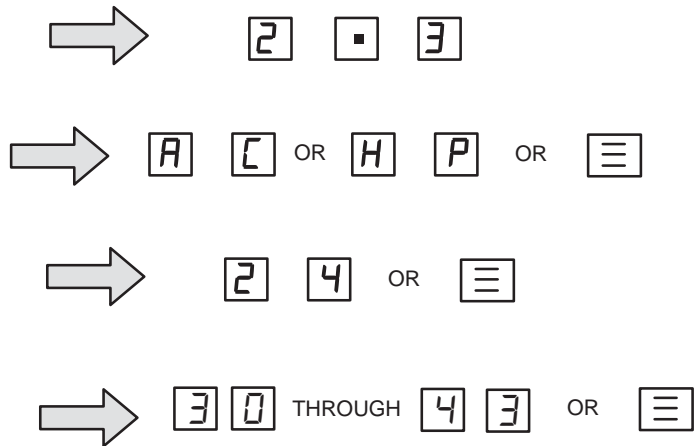

(These are just examples of firmware version, unit type, unit nominal capacity and unit codes.)

UNIT CODE	UNIT TYPE, SIZE AND MODEL
[≡]	NOT PROGRAMMED
[6] [8]	2-TON AIR CONDITIONER NS23A24M
[6] [9]	3-TON AIR CONDITIONER NS23A36M
[7] [0]	4-TON AIR CONDITIONER NS23A48M
[7] [1]	5-TON AIR CONDITIONER NS23A60M

7-SEGMENT POWER-UP DISPLAY STRING EXAMPLE

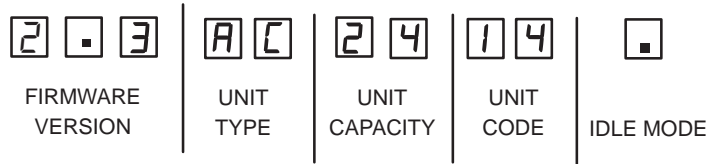

Figure 19. Outdoor Control 7-Segment Unit Status Displays

Description	Example of Display
Idle Mode: Decimal point flashes at 1 Hz.	Idle Mode: Decimal point flashes at 1 Hz (0.5 second on, 0.5 second off). Display OFF.
Soft Disable Mode: Top and bottom horizontal line and decimal point flash at 1 Hz. If indoor or outdoor control displays Soft Disable code: 1) Confirm proper wiring between all devices (thermostat, indoor and outdoor). 2) Cycle power to the control that is displaying the Soft Disable code. 3) Put the room thermostat through Setup. 4) Go to Setup/System Devices/Thermostat/Edit/push Reset. 5) Go to Setup/System Devices/Thermostat/Edit/push Reset All. If the room thermostat detects a new device or a device that is not communicating, it sends a Soft Disable. When this occurs, Alarm 10 is activated and the room thermostat sends a Soft Disable command to the offending device on the bus (outdoor control, IFC, AHC, EIM or Damper Control Module).	Soft Disable Mode: Top and bottom horizontal line and decimal point flash at 1 Hz (0.5 second on, 0.5 second off). The control in Soft Disable Mode is indicated by the following: <ul style="list-style-type: none"> On AHC, IFC and outdoor controls, Soft Disable Mode is indicated by flashing double horizontal lines on the 7-segment display. On the Damper Control Module and EIM, the green LED will blink 3 seconds on and 1 second off.
O.E.M. Test Mode	All segments flashing at 2 Hz (unless error is detected). NOTE - Control should be replaced.
Anti-Short-Cycle Delay	The middle line flashes at 1 Hz for 2 seconds, followed by a 2-second display of the number of minutes left on the timer (value is rounded up: 2 min. 1 sec. is displayed as 3). If activated, the anti-short cycle delay time remaining is displayed (default is 300 sec./5 min.).
Cooling Capacity: Shows cooling stage C1 or C2 operating.	Cooling compressor capacity (1second on, 0.5 second off) followed by ambient temperature. 24 VAC thermostat with second stage cooling active and ambient of 95F : C 2 pause A 9 5 repeat. C 5 0 pause A 7 6
Diagnostic recall: Shows the last 10 stored diagnostic error codes.	If first error is E 2 5 0, second E 2 3 1 pause E 2 5 0 pause E 2 3 1 Next codes (up to 10) are shown using same method.
Fault memory clears	If there are no error codes stored: E pause 0 0 0. After the fault memory is cleared, the following string flashes every 0.5 seconds: 0 0 0 0 pause
Active error in outdoor control Idle mode: Show all active error(s) codes.	Following display string is repeated if Error E 125 and E 201 are present: E 1 2 5 pause E 2 0 1
Active error in run mode: Show current status and all active error(s) codes.	Following display string is repeated if Error E 440 is present while cooling demand is 80 percent: C 8 0 pause E 4 4 0
Outdoor Ambient Temperature (OAT): Any time OAT is within operating range, value is displayed if unit is in diagnostic and non-diagnostic modes.	Following display string is repeated if cooling is active and OAT is 104°F: C 3 5 pause A 1 0 4 pause
Liquid Line Temperature (LIQ): Any time LIQ is sensed in operating range, value is displayed if unit is in diagnostic mode or manually enabled for non-diagnostic modes.	Following display string is repeated if cooling is active and LIQ is 105°F: C 3 1 pause L 1 0 5 pause

Table 12. Outdoor Control 7-Segment Unit Status Displays

Description	Example of Display
Charge Mode: When unit is in the charge mode, Suction pressure (SPxxx), Suction Temp (Stxx.x), Superheat (SHxx.x), Liquid pressure (LPxxx), Liquid Temp (Ltxx.x) and subcooling (SCxx.x) will be scrolled on the 7-segment display	The following string is repeated: 5 P 1 3 5 pause 5 t 6 2 pause 5 H 1 5 pause L P 3 4 5 pause L t 9 6 pause 5 C 1 0 Repeat

Table 12. Outdoor Control 7-Segment Unit Status Displays

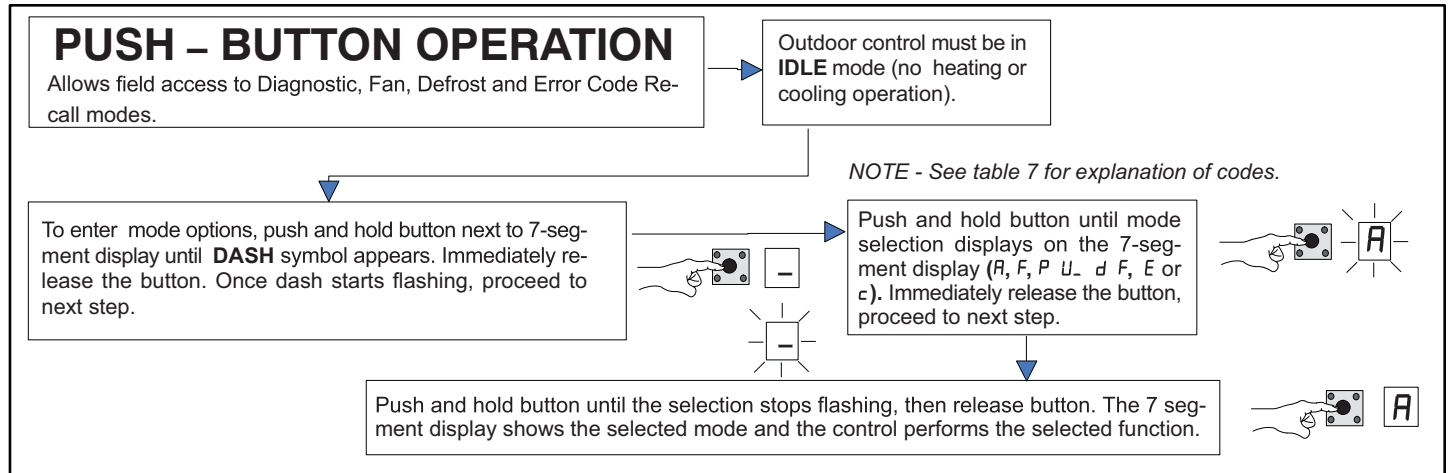

Figure 20. Push-Button Operation

Unit Selection Code for Outdoor Control

If the single-character display shows three (3) horizontal lines, the unit selection code needs to be programmed. Press and hold the button until the P U menu option is displayed, release button. The single-character display displays the selected mode per example in Figure 23 on page 51. When the desired unit selection code appears, press and hold the button until it stops flashing, then release.

Unit Code	Unit Type	Unit Model
68	2-ton air conditioner	NS23A24M
69	3-ton air conditioner	NS23A36M
70	4-ton air conditioner	NS23A48M
71	5-ton air conditioner	NS23A60M

Table 13.

Idle mode – System is energized with no demand – Decimal flashes at 1 Hertz > 0.5 second ON. 0.5 second OFF		
Display Symbol or Character	Display	Fan Test and Display String Option
Displayed during start-up or power recycling	Display string shows outdoor control firmware version I _ B > pause > R C or H P unit > pause > unit capacity in BTUs > pause > unit code. If 3 horizontal bars are displayed during any sequence of this display string, it indicates that the specific parameter is not configured.	
.	Idle mode — decimal flashes at 1 Hertz > 0.5 second ON, 0.5 second OFF	
C	Indicates cooling Capacity. C1 or C2 for conventional 24VAC thermostat	
F	Indicates you are in the outdoor fan test mode	Control must be in Idle mode: To enter fan test option - F mode, push and hold button until solid – appears, release button. Display begins flashing. Within 10 seconds, push and hold button until required symbol F displays, release button. Display begins flashing. Within 10 seconds, push and hold button until display stops flashing, release button. Control will initiate outdoor fan operation. Outdoor fan cycles ON for 10 minutes at the highest speed. To exit test – Push and hold button until three horizontal bars display. Release button, outdoor fan cycles OFF .
R	R in the display string represents the ambient temperature in °F at the sensor on the outdoor unit.	Control can be in Idle or demand mode: To enter display configuration option - R mode, push and hold button until solid – appears, release button. Display begins flashing. Within 10 seconds, push and hold button until required symbol R displays, release button. Display begins flashing. Within 10 seconds, push and hold button until display stops flashing, release button. Display shows error (E) code(s) and ambient (R), outdoor coil (C) and liquid (L) temperatures in Fahrenheit. NOTE - If button is not pushed in the 10-second time period, the control exits the test mode. If this occurs, test mode must be repeated.

Table 14.

Error Code Recall Mode (NOTE – control must be in idle mode)	
E	To enter error code recall mode, push and hold button until solid E appears, then release button. Control displays up to 10 error codes stored in memory. If E □ □ □ □ is displayed, there are no stored error codes.
≡	To exit error code recall mode, push and hold button until solid three horizontal bars appear, then release button. Note - Error codes are not cleared.
C	To clear error codes stored in memory, continue to hold button while the 3 horizontal bars are displayed. Release button when solid C is displayed.
C	Push and hold for one (1) second, release button. 7-Segment displays 0 0 0 0 and exits error recall mode.

Table 15.

Field Test Mode Operation

The field test mode allows the unit to be put into diagnostic mode and allows the installer to perform multiple tests on the control / unit.

Diagnostic Mode

Diagnostic mode is only available when the system is idle or during an active / suspended call for heating or cooling. Diagnostic mode is terminated when the exit command is given, the button is pressed and released without entering the diagnostic menu or 10 minutes has passed, whichever comes first.

When this mode is selected all installed temperature sensor valves (non-open and non-short) are shown on the 7-segment display. The following system status codes are displayed:

- Cooling
- Cooling stage or cooling percentage demand operation
- Active error codes

Outdoor Fan Mode

Diagnostic mode is only available while the system is in idle mode. This mode can be exited with the proper command or after 10 minutes has passed.

In diagnostic mode, the control energizes the outdoor fan at the highest speed.

Charge Mode Operation

To initiate the NS23AM Charge Mode function, install the jumper across the two Charge Mode Pins (CHRG MODE) on the outdoor control. The Charge Mode can be used when charging the system with refrigerant, checking the refrigerant charge, pumping down the system and performing other service procedures that requires outdoor unit operation at 100% capacity.

NS23AM Charge Mode Operation with a Conventional 24VAC Thermostat

On applications with a conventional 24VAC thermostat, the charge mode jumper must be installed on the Charge Mode Pins after providing a Y1 cooling demand to the NS23AM to initiate the Charge Mode. A cooling blower demand must also be provided to initiate blower operation on the cooling speed on the indoor unit. The compressor and outdoor fan motor will operate at 100% capacity. To exit the charging mode, remove the Charge Mode Jumper and remove the Y1 Cooling demand and indoor blower demand. The Charge Mode has a maximum time of 60 minutes and will automatically exit the charge mode after 60 minutes is the charge mode jumper is left in place.

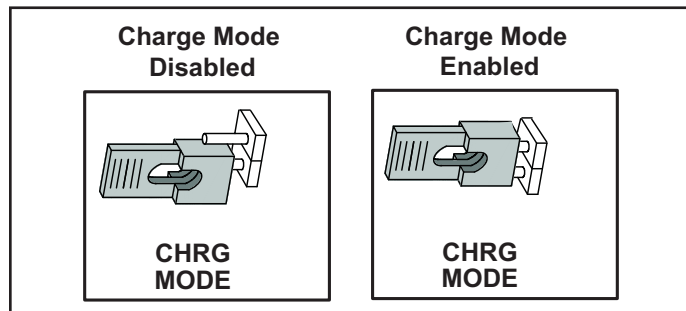

Figure 21.

Display	Display and Action (normal operation)
No Change - idle (*)	No Change - idle (*)
Solid .	Enter or exit field test and program mode.
Solid <i>R</i>	Puts unit in diagnostic mode. (Displays ambient temperatures and any active error codes.)
Solid <i>c</i>	Clears error history (**)
Solid <i>E</i>	Enter diagnostic recall mode. Displays up to 10 error codes in memory.
Solid <i>F</i>	Starts outdoor fan.
String <i>P U</i>	Enter unit code programming.
*No change indicates the display will continue to show whatever is currently being displayed for normal operations.	
**Note once the error history is deleted it cannot be recovered. After the history is deleted, the unit will reset itself.	

Table 16. Field Test, Diagnostic Recall and Program Menu Options

Display	Display and Action (normal operation)
.	Idle mode — decimal flashes at 1 Hertz > 0.5 second ON, 0.5 second OFF
C	Cooling operation. Shows cooling stage C1 or C2 operating.
E	E in the display string represents the active error code(s) in the outdoor unit. Example: C 5 0 pause E 4 4 pause E 4 4 2 pause A 7 5 pause
A	A in the display string represents the outdoor ambient temperature in °F at the outdoor sensor on the outdoor unit. Example: C 5 0 pause A 7 5
Scrolling	When unit is in the charge mode, Suction pressure (SPxxx), Suction Temp (Stxx.x), Superheat (SHxx.x), Liquid pressure (LPxxx), Liquid Temp (Ltxx.x) and subcooling (SCxx.x) will be scrolled on the 7-segement display. Example: 5 P 1 3 5 pause 5 t 6 2 pause 5 H 1 5 pause L P 3 4 5 pause L t 9 6 pause 5 C 1 0 Repeat

Table 17.

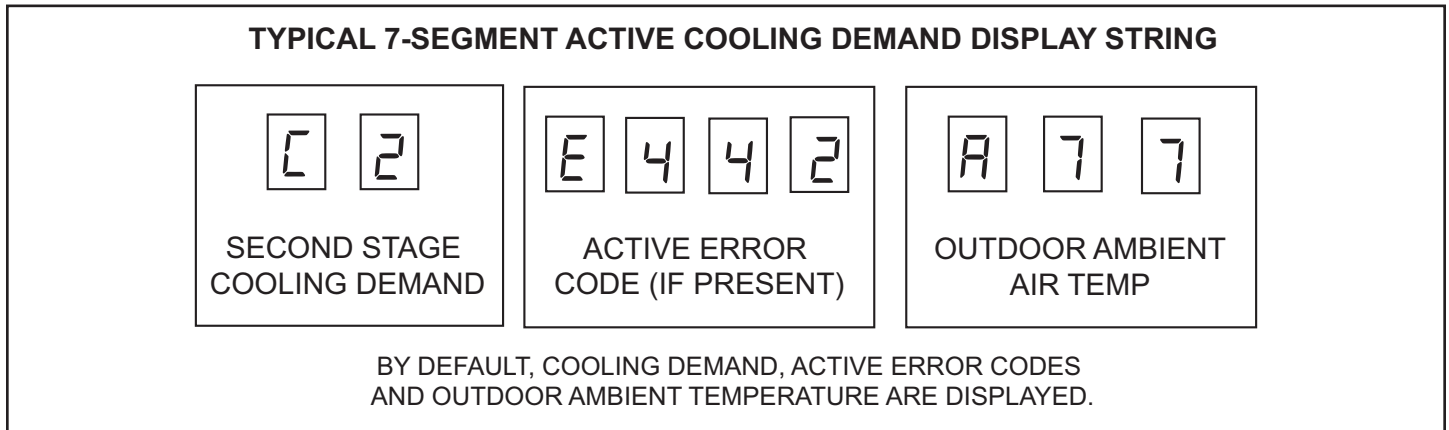

Figure 22. Typical 7-Segment Demand Display String

Configuring Unit

When installing a replacement outdoor control, the unit selection code may have to be manually assigned using the 7-segment display and push button on the control. The unit code sets unit type, capacity and outdoor fan profile.

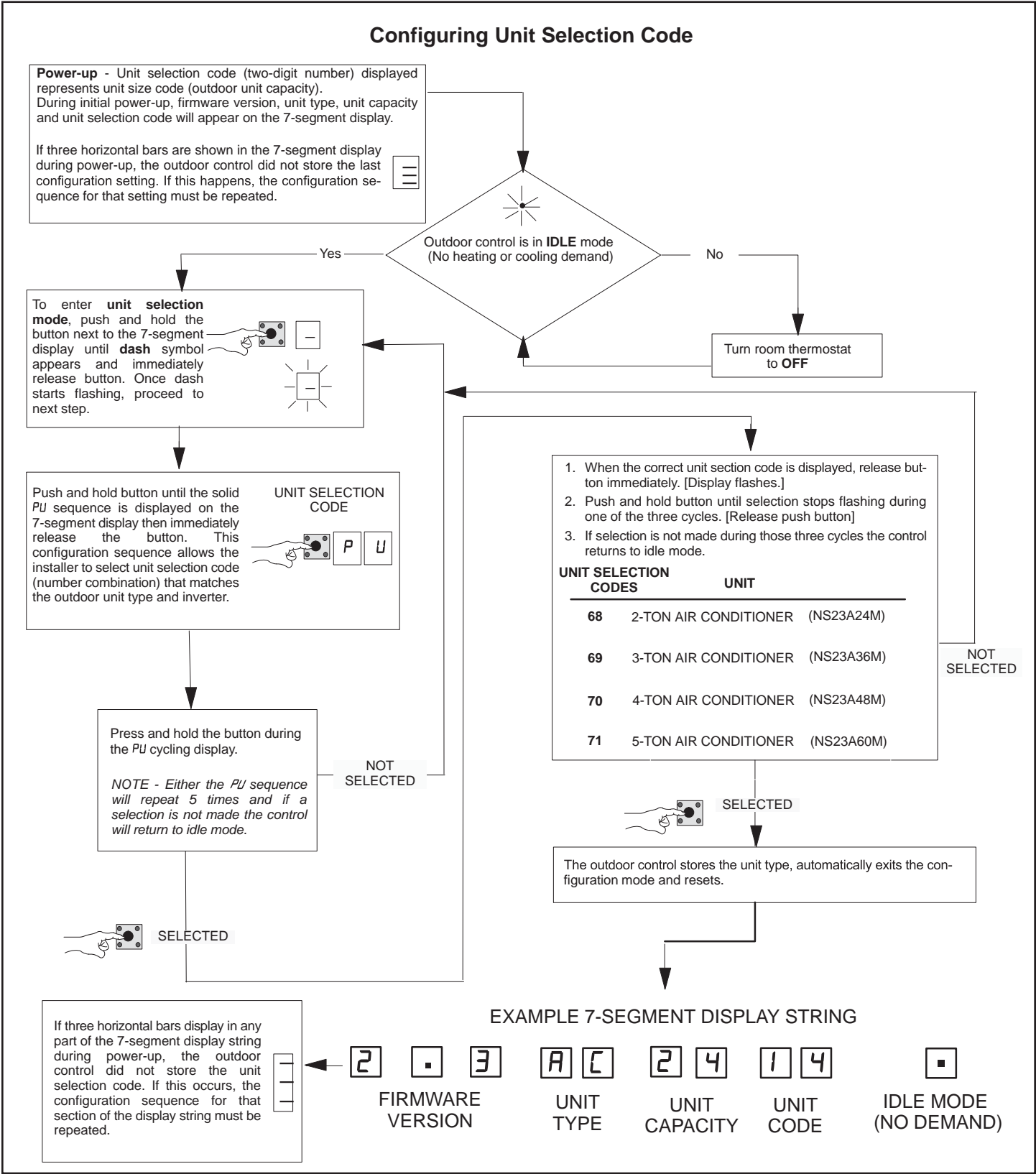

Figure 23. Configuring Unit Selection Code

System Overview

Refer to the applicable Thermostat Installer Setup Guide for configuration procedures.

The outdoor control provides the following functions:

- Internal switching of outputs.
- Compressor anti-short-cycle delay (adjustable through the thermostat interface).
- Five-strike lockout function.
- High Pressure protection using the High Pressure Switch (S4) and Low Pressure Protection protection using the Suction Pressure Transducer with setpoints that emulates a low pressure switch. (Cut-out of 40 psig and cut-in of 90 psig).
- Ambient (RT13), liquid line (RT36) and suction line (RT41) temperatures for monitoring and protection.

Compressor Protection – Five-Strike Lockout

The five-strike lockout function is designed to protect the compressor from damage. The five-strike feature is used for both high (S4) and low (S87) pressure switches.

Resetting Five-Strike Lockout

Once the condition has been rectified, power to the outdoor control R terminal must be cycled OFF.

Crankcase Heater (HR1)

Compressors in all units are equipped with a 40-watt bellyband- type crankcase heater. HR1 prevents liquid from accumulating in the compressor. HR1 is controlled by the crankcase heater thermostat.

Crankcase Heater Thermostat (S40)

Thermostat S40 controls the crankcase heater in all units. S40 is located on the liquid line. When liquid line temperature drops below 50°F, thermostat S40 closes, energizing HR1. The thermostat opens, de-energizing HR1, once liquid line temperature reaches 70°F.

Maintenance

Outdoor Unit

Maintenance and service must be performed by a qualified installer or service agency. At the beginning of each cooling season, the system should be checked as follows:

1. Clean and inspect outdoor coil (may be flushed with a water hose). Ensure power is off before cleaning.
2. Outdoor unit fan motor is factory-lubricated and sealed. No further lubrication is needed.
3. Visually inspect all connecting lines, joints and coils for evidence of oil leaks.
4. Check all wiring for loose connections.
5. Check for correct voltage at unit (unit operating).
6. Check amp draw on outdoor fan motor.
7. Inspect drain holes in coil compartment base and clean if necessary.

NOTE: *If insufficient heating or cooling occurs, the unit should be gauged and refrigerant charge should be checked.*

Outdoor Coil

It may be necessary to flush the outdoor coil more frequently if it is exposed to substances which are corrosive or which block airflow across the coil (e.g., pet urine, cottonwood seeds, fertilizers, fluids that may contain high levels of corrosive chemicals such as salts).

- Outdoor Coil — The outdoor coil may be flushed with a water hose.
- Outdoor Coil (Coastal Area) — Moist air in ocean locations can carry salt, which is corrosive to most metal. Units that are located near the ocean require frequent inspections and maintenance. These inspections will determine the necessary need to wash the unit including the outdoor coil. Consult your installing contractor for proper intervals/procedures for your geographic area or service contract.

Indoor Unit

1. Clean or change filters.
2. Blower motors are factory-lubricated and permanently sealed. No more lubrication is needed.
3. Adjust blower speed for cooling. Measure the pressure drop over the coil to determine the correct blower CFM. Refer to the unit information service manual for pressure drop tables and procedure.
4. Check all wiring for loose connections.
5. Check for correct voltage at unit. (blower operating)
6. Check amp draw on blower motor.

Indoor Coil

1. Clean coil if necessary.
2. Check connecting lines, joints and coil for evidence of oil leaks.
3. Check condensate line and clean if necessary.

Unit Wiring Diagram

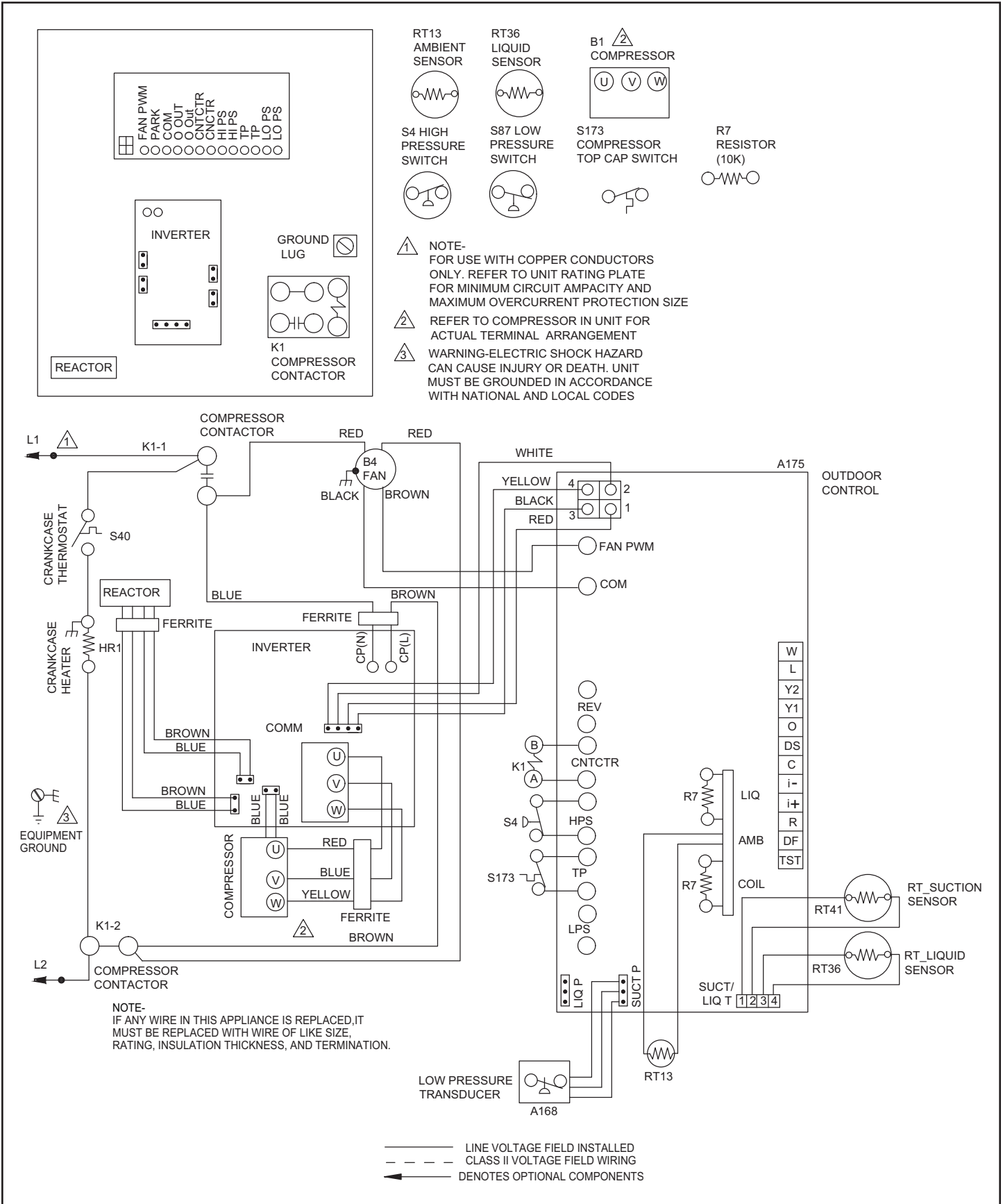

Figure 24. Wiring Diagram

Unit Sequence of Operation

The following figures illustrate the overall unit sequence of operation along with the operation of various pressure switches and temperature sensors. The figures also illustrate the use of the compressor anti-short-cycle function in relation to unit Status, unit Fault and lockout LED Codes and unit system operation interactions.

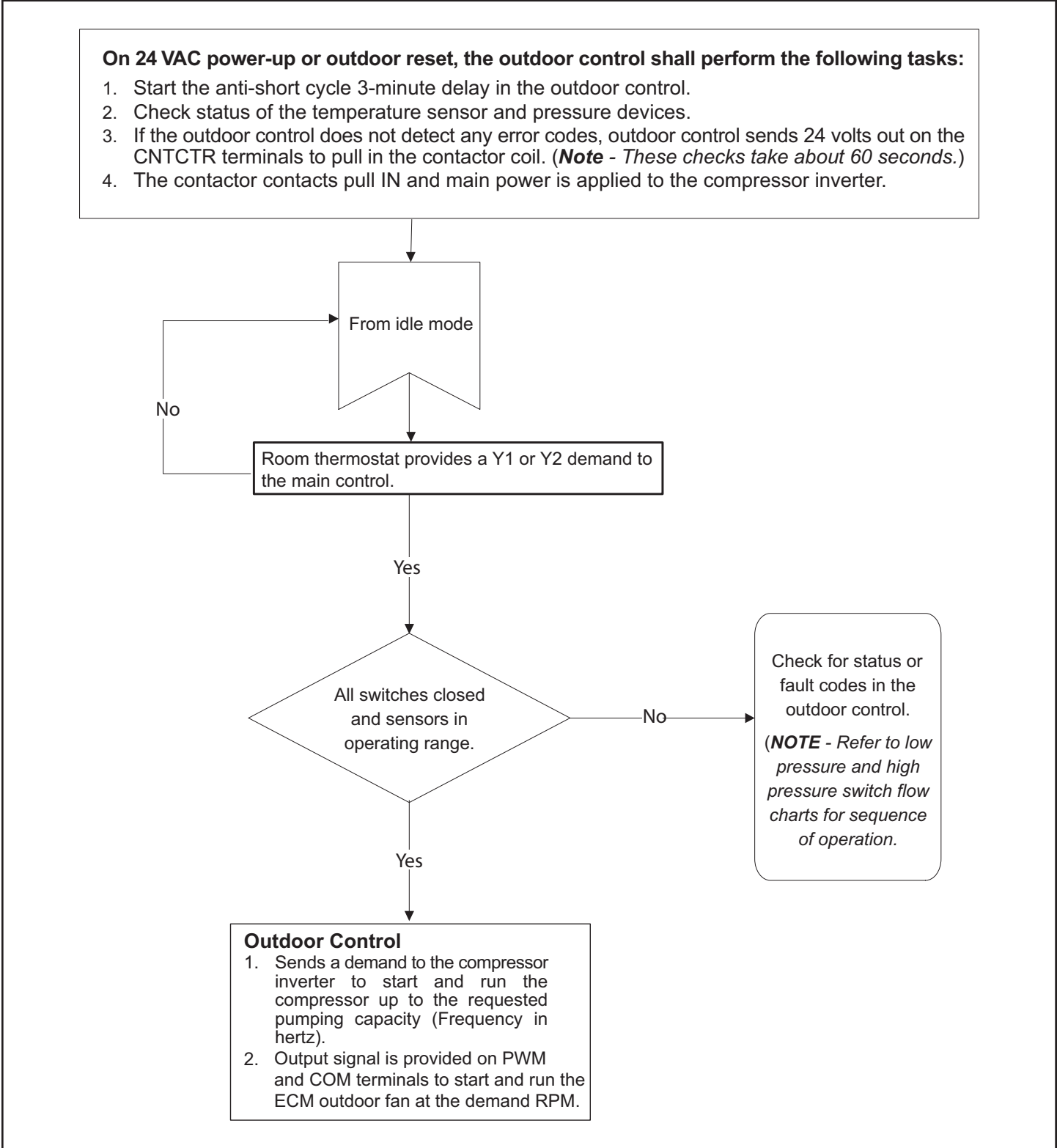

Figure 25. Volt Power-Up or Outdoor Reset

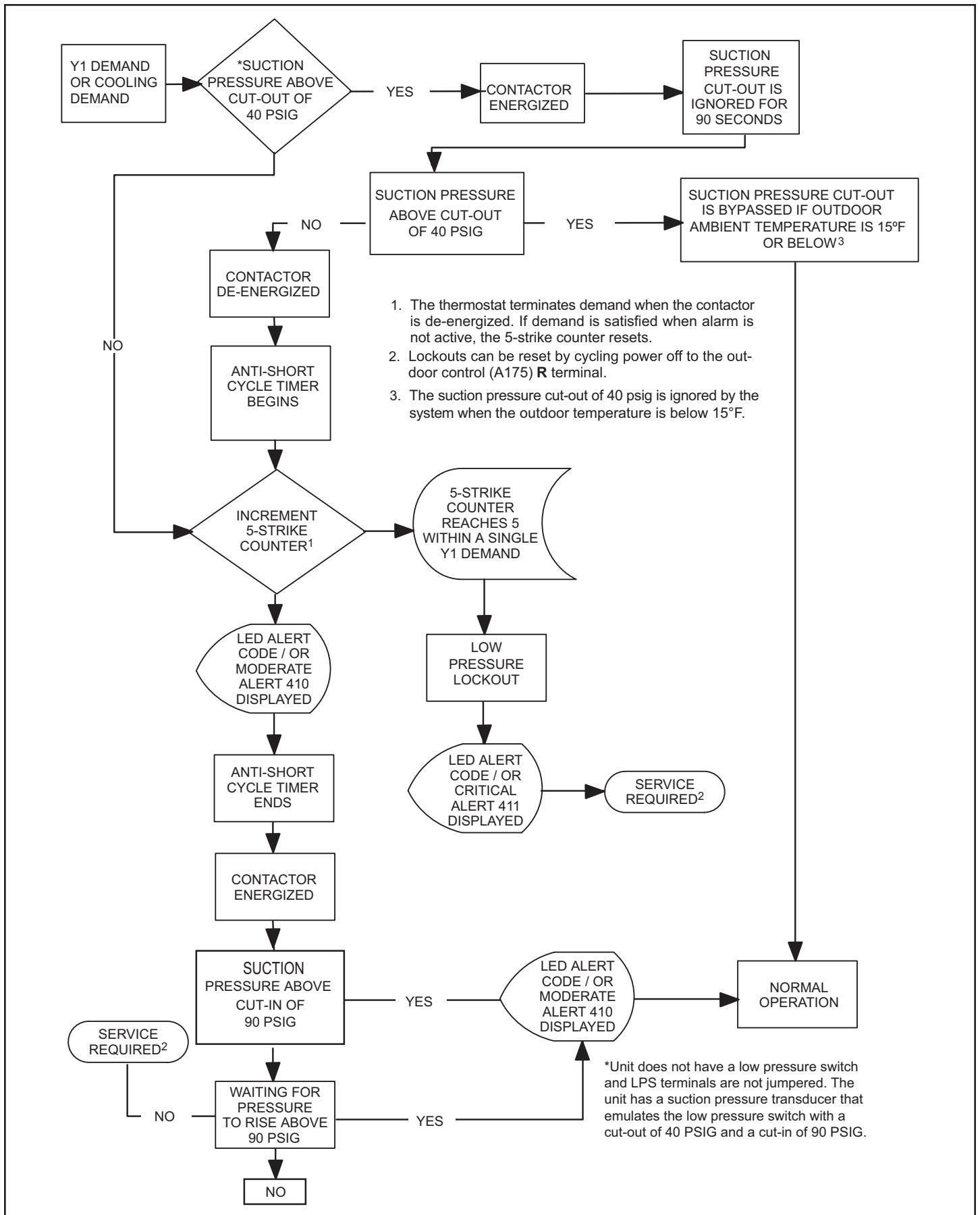

Figure 26. Low Pressure Switch Emulated by Suction Pressure Transducer Sequence of Operation (All Units)

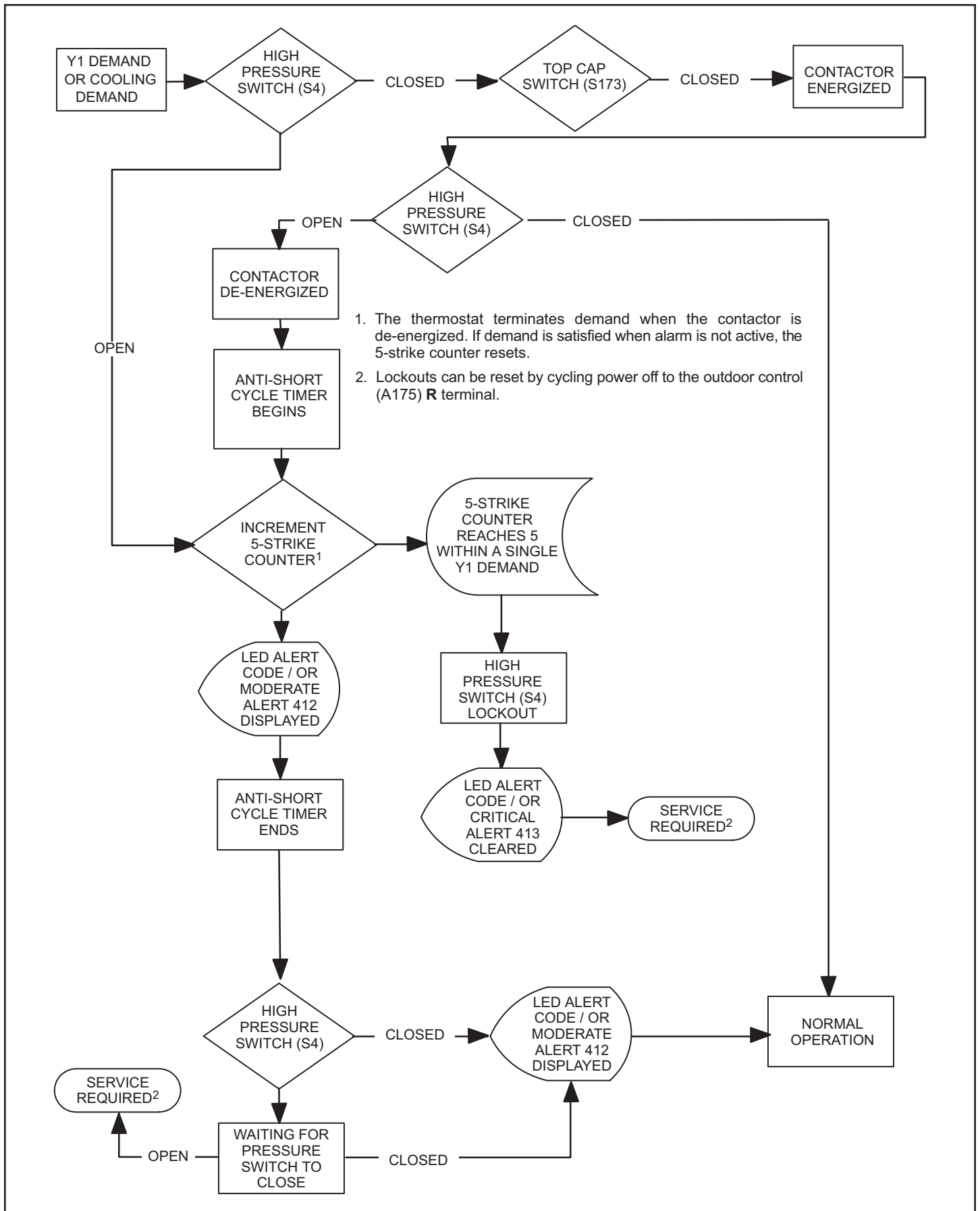

Figure 27. High Pressure Switch (S4) Sequence of Operation (All Versions)

Component Testing

Verifying High Pressure Switch and Low Pressure Protection Operation

Operation:

The unit's pressure S4 high pressure switch is factory wired into the control on the HPS terminals.

NOTE: The NS23AM does not have a low pressure switch and LPS terminals are not jumpered. The unit has a suction pressure transducer that emulates the low pressure switch with a cut-out of 40 PSIG and a cut-in of 90 PSIG. This provides the same protection as a traditional low pressure switch. If the event the suction pressure transducer fails, back up protection is provided by the suction temperature sensor and will open at 25F.

Low Suction Pressure Protection – See Figure 29 for low suction pressure protection sequence of operation.

High Pressure Switch (HI-PS) – See for high pressure switch sequence of operation.

Pressure Switch Event Settings

The following pressures are the auto-reset event value triggers for low and high pressure thresholds:

- High Pressure (auto-reset) - trip at 590 psig; reset at 418.
- Low Suction Pressure Protection (Suction pressure transducer emulates LPS) (auto-reset) – trip at 40 psig; reset at 90.

Checkout – S4 High Pressure Switch

Using a multimeter set to ohms with the terminals disconnected from the control board, check the resistance between the two terminals of the pressure switch. If the resistance reading is 0 ohms, the switch is closed.

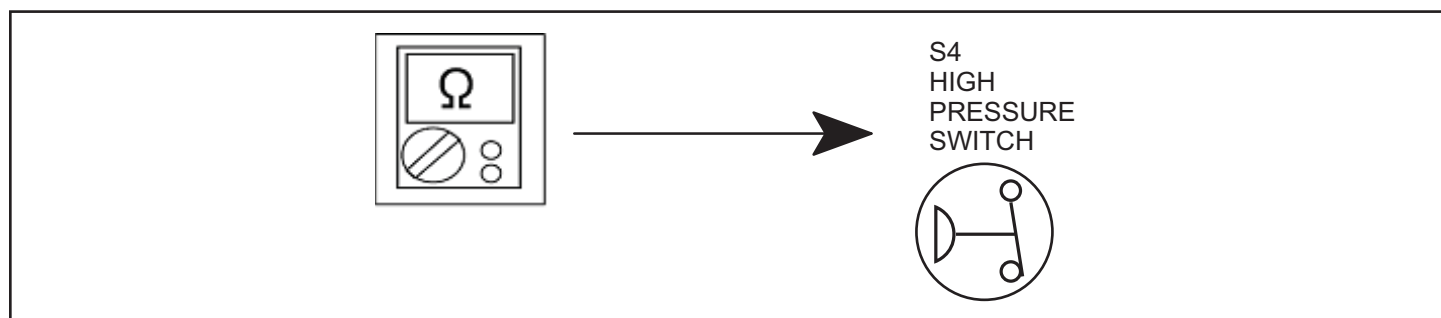

Figure 28. Verifying High Pressure Switch Operation

Verifying Suction Pressure Transducer Operation

Using a multimeter set to VDC with the Suction Pressure Transducer connected to the "Suct P" 3-pin connector on the control board. Pin 1 (Red wire +5VDC) to Pin 3 (Black wire - GND) should read 5 VDC continuous. Pin 2 (Blue wire output from transducer) to Pin 3 (Black - GND) should read 0.5 to 4.5 VDC and will vary depending on suction pressure measured. See Table 18.

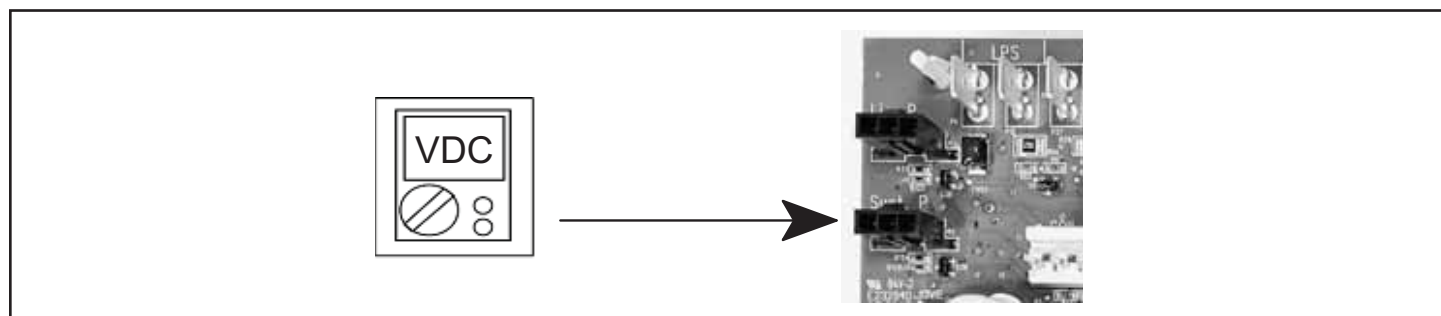

Figure 29. Suction Pressure Transducer Voltage

Suction Pressure (PSIG)	DC Voltage Output (Pin 2 to Pin 3)	Suction Pressure (PSIG)	DC Voltage Output (Pin 2 to Pin 3)
0	0.49	110	2.69
10	0.69	120	2.89
20	0.89	130	3.09
30	1.09	140	3.29
40	1.29	150	3.49
50	1.49	160	3.69
60	1.69	170	3.89
70	1.89	180	4.09
80	2.09	190	4.29
90	2.29	200	4.49
100	2.49	210	4.50

Table 18. Suction Pressure Transducer Output Voltage

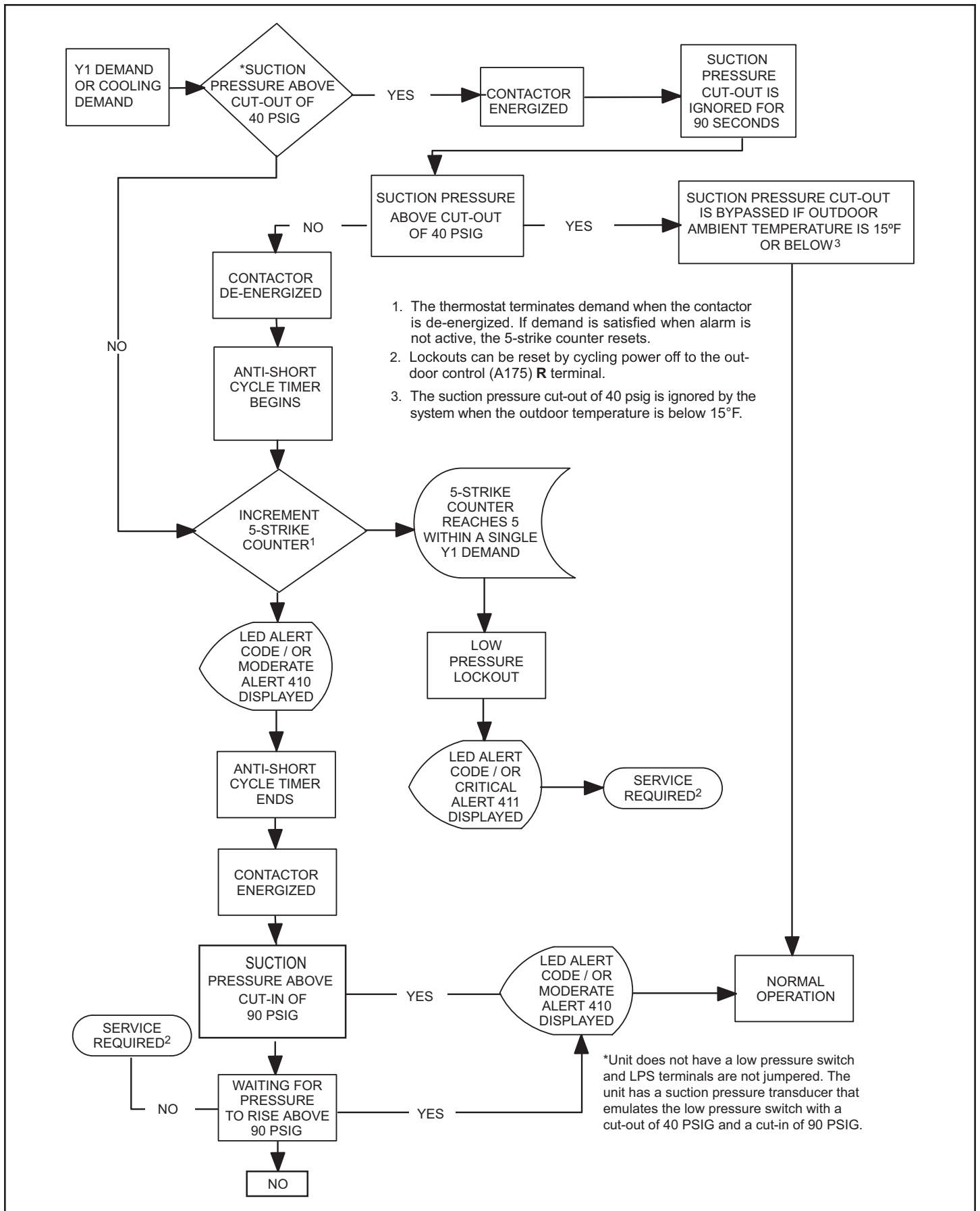

Figure 30. Low Pressure Switch Emulated by Suction Pressure Transducer Sequence of Operation (All Units)

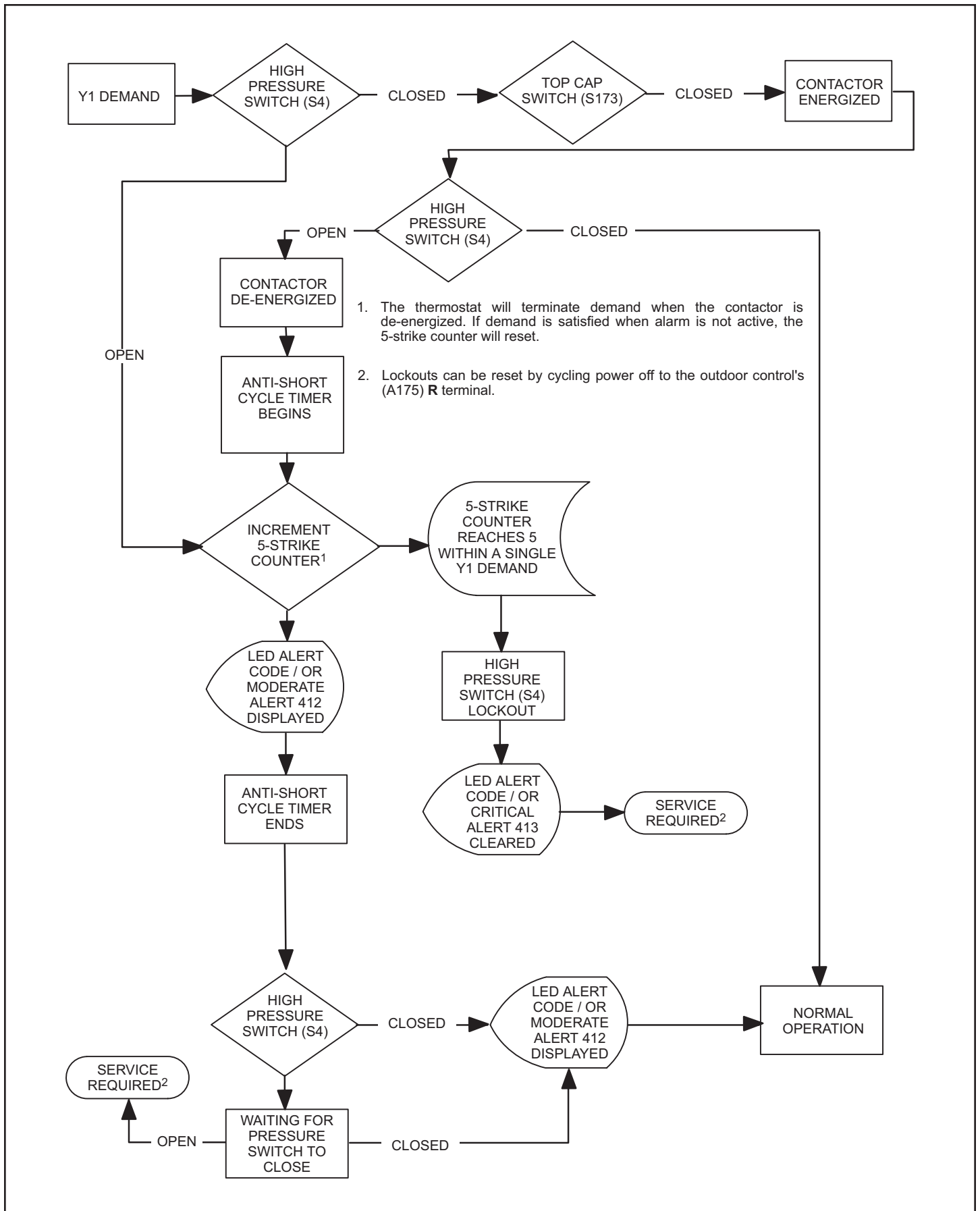

Figure 31. High Pressure Switch (S4) Sequence of Operation (All Versions)

High Pressure Switch Protection Errors

NOTE: System fault and lockout codes take precedence over system status codes (cooling, heating operating percentages or defrost/dehumidification). Only the latest active fault or lockout codes are displayed (if present). If no fault or lockout codes are active, then system status codes are displayed.

GF= Gas Furnace, AH=Air Handler, ID=Indoor unit (GF or AH), HP=Heat Pump, AC=Air Conditioner, OD=Outdoor Unit (AC or HP), ZA=Zone system and TS=Thermostat

Alert Code	Inverter Flash Code	Priority Condition	Actual Displayed Alert Text	Component or System Operational State and Troubleshooting Tip	How to Clear Alert Code
412		Information Only-Dealer	OD Open High Pressure Switch	<p>The unit high pressure is above the upper limit. System will shut down.</p> <p>Confirm that the system is properly charged with refrigerant.</p> <p>Check condenser fan motor, expansion valve (if installed), indoor unit blower motor, stuck reversing valve or clogged refrigerant filter.</p> <p>Confirm that the outdoor unit is clean.</p>	Automatically clears after the high pressure switch closes or a power reset.
413		Service Urgent	OD High Pressure Switch Strikes Lockout	<p>The high pressure switch has opened five times during one cooling demand. Thermostat will shut down the outdoor unit.</p> <p>Open high pressure switch error count reached five strikes.</p> <p>Check system charge using superheat and sub-cooling temperatures.</p> <p>Check outdoor fan operation.</p> <p>Check for dirt or debris blocking air flow to outdoor unit.</p> <p>Reset by putting outdoor unit control in test mode or resetting low voltage power.</p>	Automatically clears when the system detects that the issue no longer exists.

Table 19. Alert Codes and Troubleshooting

Compressor Operation, Checkout and Status / Error Codes

Operation:

The NS23AM uses two different types of compressor, depending on the specific model. The NS23AM24, 36 and 48 use a 380VAC three phase variable capacity rotary compressor specifically designed for unitary splits system and is approved for use with HFC 410A refrigerant. The NS23AM60 unit uses a 380VAC three phase variable capacity scroll compressor that is approved for use with HFC 410A refrigerant. The compressor, when connected to an inverter, is capable of operating in a running frequency range from 20 hertz up to a maximum of 70 hertz. (maximum hertz is dependent on compressor size). The compressor speed is determined by suction pressure when installed with a conventional 24VAC thermostat.

Checkout:

NOTE: The compressor motor winding resistance is the nominal resistance at 77F. When measuring compressor motor winding resistance, the primary concern is the winding resistance between the different sets of terminals within 10% of each other. The actual winding resistance is impacted by temperature, refrigerant and oil. Do not automatically condemn a compressor because the measured resistance is slightly higher or lower than the nominal resistance. Check for shorted/open windings and for shorts to ground during testing.

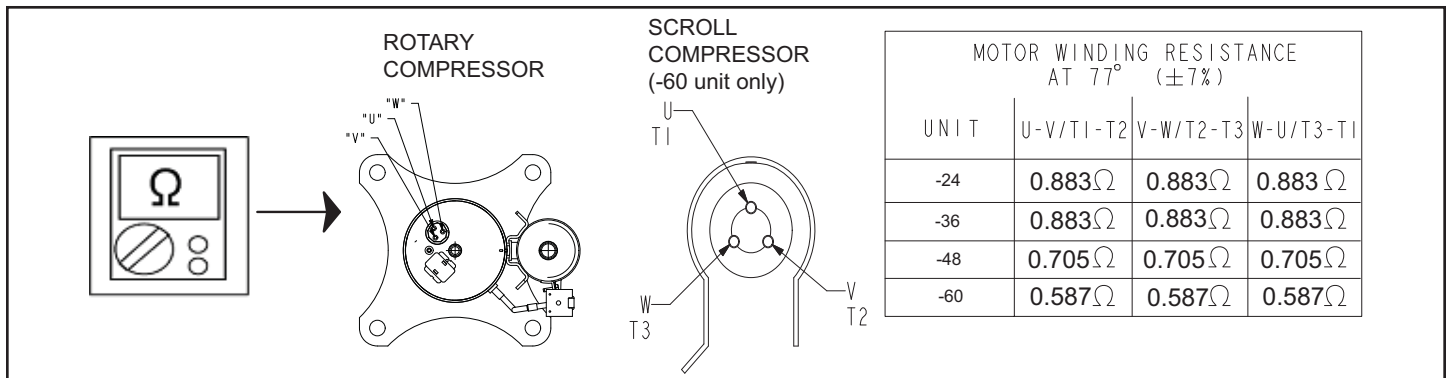

Figure 32. Compressor Operation, Checkout and Status/Error Codes

NOTE: If compressor replacement is required, remove the compressor through the top of the unit. Removal through the access panel is not possible.

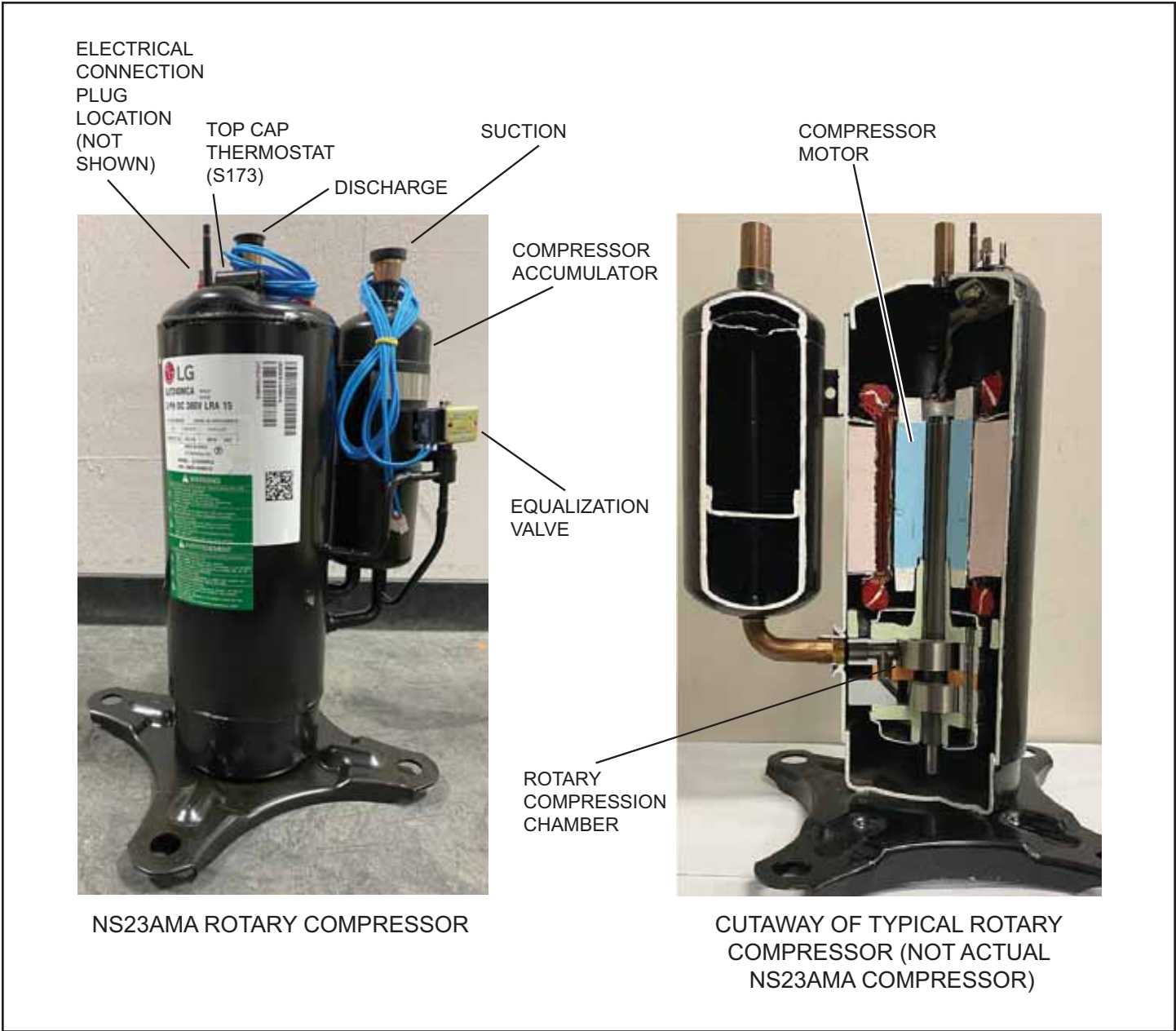

Figure 33. NS23AM Rotary Compressor Detail (All Models except NS23A60M)

Status Codes:

When the compressor is running, the 7-segment display will show the compressor capacity. When the NS23AM unit is installed with a conventional 24VAC thermostat the display will show C 1 or C 2.

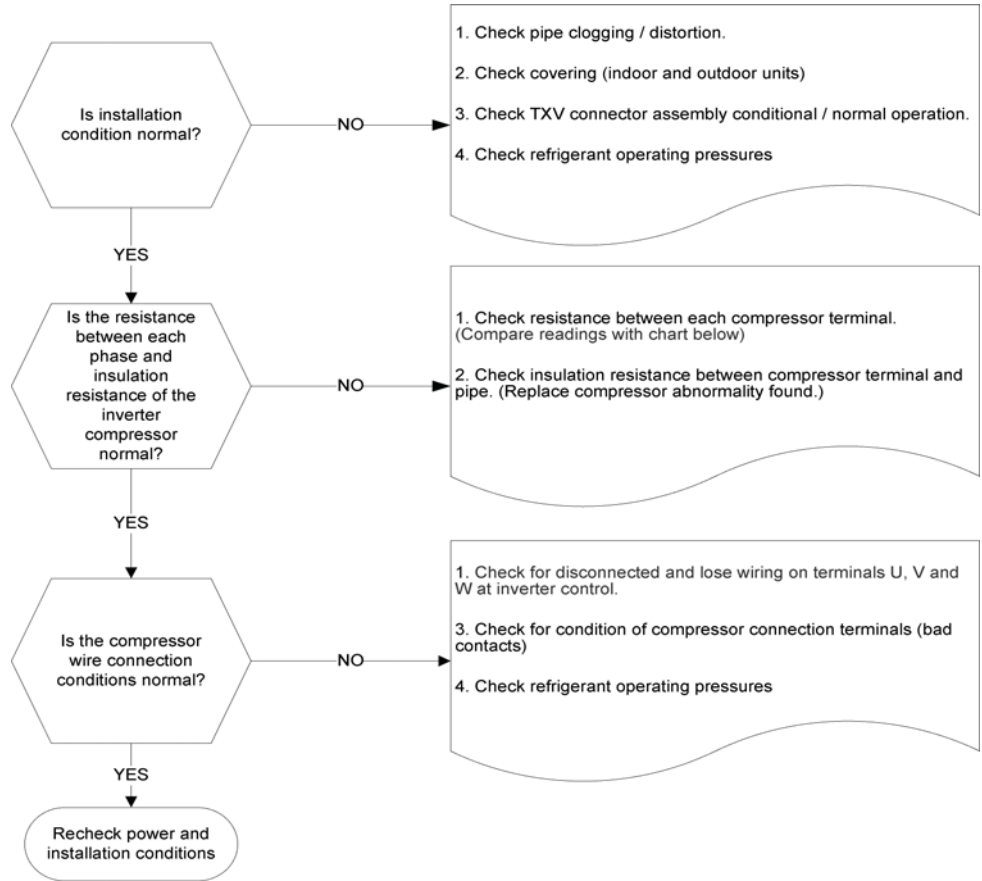

Figure 34. Compressor Operation, Checkout and Status/Error Codes

Error Codes:

NOTE: System fault and lockout codes take precedence over system status codes (cooling, heating operating percentages or defrost/dehumidification). Only the latest active fault or lockout codes are displayed (if present). If no fault or lockout codes are active, then system status codes are displayed.

GF= Gas Furnace, AH=Air Handler, ID=Indoor unit (GF or AH), HP=Heat Pump, AC=Air Conditioner, OD=Outdoor Unit (AC or HP), ZA=Zone system and TS=Thermostat

Alert Code	Inverter Code	Inverter Flash Code		Priority Condition	Actual Displayed Alert Text	Component or System Operational State and Troubleshooting Tip	How to Clear Alert Code
		Red LED	Green LED				
430	26	2 flashes	6 flashes	Service Soon/ Service Urgent	OD Inverter Compressor Startup Fail	<p>Compressor start-up failure.</p> <ul style="list-style-type: none"> If condition is detected, outdoor unit will stop (compressor and fan) – moderate condition. Anti-short cycle is initiated. If condition occurs 10 times within 60 consecutive minutes, the system will lockout – critical condition. Inverter LEDs will flash code 26. Refer to the unit service documentation for detailed troubleshooting procedures. <p>Inverter flash code 26.</p> <p>The sequence is:</p> <ul style="list-style-type: none"> Red LED: Two Flashes Green LED: Six Flashes <p>NOTE: Inverter normal operations with no error code present is as follows. Red LED is ON and Green LED is OFF.</p> <ul style="list-style-type: none"> Check refrigerant Replace outdoor control board Replace inverter. 	To clear, disconnect power to outdoor unit and restart.
433	29	2 flashes	9 flashes	Service Soon/ Service Urgent	OD Inverter Compressor Over-current	<p>Compressor phase current is too high.</p> <ul style="list-style-type: none"> During initial startup, a six minute time delay is implement to prevent the alarm from occurring. Error occurs when compressor peak phase current is greater than 28 amps. Inverter will issue inverter code 14 first and slow down to try to reduce the current. If the current remains high, outdoor unit will stop (compressor and fan) – moderate condition. Cycle timer is initiated. If condition occurs five times within 60 consecutive minutes, the system will lockout – critical condition. This alert code may be triggered by the inverter or the GE Appliances variable capacity outdoor (inverter controlled) unit. GE Appliances outdoor control may trigger an this alert code if the inverter reduces the compressor speed which is identified as a alert code 441 and the compressor speed (in hz) is below the minimum speed. This will typically occur at start-up. The inverter automatically increases the compressor minimum speed below 45°F in the heating mode and above 115°F ensure the compressor capacity is sufficient for oil return. If alert code 433 occurs and inverter does not indicate an inverter code 29, the GE Appliances outdoor control triggered the alert code 433. Inverter LEDs will flash code 29. Refer to the unit service documentation for detailed troubleshooting procedures. <p>Inverter flash code 29.</p> <p>The sequence is:</p> <ul style="list-style-type: none"> Red LED: Two Flashes Green LED: Nine Flashes <p>NOTE: Inverter normal operations with no error code present is as follows. Red LED is ON and Green LED is OFF.</p>	To clear alert code disconnect power to both the indoor and outdoor units and then reconnect power. Restart system.

Table 20. Outdoor Control 7-Segment Display Alert Codes - Compressor

NOTE: System fault and lockout codes take precedence over system status codes (cooling, heating operating percentages or defrost/dehumidification). Only the latest active fault or lockout codes are displayed (if present). If no fault or lockout codes are active, then system status codes are displayed.

GF= Gas Furnace, AH=Air Handler, ID=Indoor unit (GF or AH), HP=Heat Pump, AC=Air Conditioner, OD=Outdoor Unit (AC or HP), ZA=Zone system and TS=Thermostat

Alert Code	Inverter Code	Inverter Flash Code		Priority Condition	Actual Displayed Alert Text	Component or System Operational State and Troubleshooting Tip	How to Clear Alert Code
		Red LED	Green LED				
440	13	1 flash	3 flashes	Information Only-Dealer	OD Inverter Compressor Slowdown - High Heat-Sink temperature	<p>Compressor slowdown due to high heat sink temperature.</p> <ul style="list-style-type: none"> Heat sink temperature is approaching limit. The compressor speed automatically slows to reduce heat sink temperature. The control sets indoor CFM and outdoor RPM to values according to demand percentage rather than the actual Hz. The screws that hold the inverter to the inverter board may be loose causing poor contact between these two components. Tighten screws that hold the heat sink to the inverter control board. <p>NOTE: Wait five minutes for all capacitors to discharge before checking screws.</p> <ul style="list-style-type: none"> This error code is primarily for informational purposes as the inverter controls the compressor speed to operate within design parameters. Typically the inverter will make a minor speed reduction of 4 Hz (approximately a 5-6% speed reduction) for a brief period of time and to reduce the heat sink temperature and will then resume normal operation. This may occur at high outdoor temperatures (above 110°F) for brief periods of time (3 – 4 minutes) and is normal and expected operation of the inverter controlling the compressor safely within design parameters. The inverter finned aluminum heat sink is located on the back side of the inverter in the condenser air stream. If the alert code 440 occur frequently, especially at lower outdoor temperatures, check the heat sink for debris that may reduce heat transfer or possible obstructions that may impact air flow across the heat sink. The inverter will begin to briefly reduce the compressor speed when the heat sink temperature rises above 185°F and will allow the inverter to resume the requested compressor demand speed once the inverter heat sink reaches 176°F. The heat sink temperature, compressor speed in Hertz & the Inverter Compressor Speed Reduction status ("On" or "Off") notification can be viewed under the outdoor unit Diagnostics section of the thermostat dealer control center. Inverter LEDs will flash code 13. Refer to the unit service documentation for detailed troubleshooting procedures. <p>Inverter flash code 13.</p> <p>The sequence is:</p> <ul style="list-style-type: none"> Red LED: One Flash Green LED: Three Flashes <p>NOTE: Inverter normal operations with no error code present is as follows. Red LED is ON and green LED is OFF.</p>	Automatically clears when the condition no longer exists.

Table 20. Outdoor Control 7-Segment Display Alert Codes - Compressor

NOTE: System fault and lockout codes take precedence over system status codes (cooling, heating operating percentages or defrost/dehumidification). Only the latest active fault or lockout codes are displayed (if present). If no fault or lockout codes are active, then system status codes are displayed.

GF= Gas Furnace, AH=Air Handler, ID=Indoor unit (GF or AH), HP=Heat Pump, AC=Air Conditioner, OD=Outdoor Unit (AC or HP), ZA=Zone system and TS=Thermostat

Alert Code	Inverter Code	Inverter Flash Code		Priority Condition	Actual Displayed Alert Text	Component or System Operational State and Troubleshooting Tip	How to Clear Alert Code
		Red LED	Green LED				
441	14	1 flash	4 flashes	Information Only-Dealer	OD Inverter Compressor Slowdown - High Compressor Current	<p>This alert code is for more information than an issue with the system.</p> <ul style="list-style-type: none"> When the inverter gets close to the current or heat sink temperature limit, it will limit the ramp rate. Instead of changing compressor speed at 1 hz/second, it changes to 5 hz/20 seconds. Compressor slowdown due to high compressor current. Compressor current is approaching limit. The compressor speed automatically slows. This error code is primarily for informational purposes as the inverter controls the compressor to operate within design parameters. Alert code 441 typically occurs at startup as the compressor current increases rapidly during startup. The inverter will reduce the compressor speed by 4 Hz and slow the compressor ramp up speed to the requested compressor demand speed (capacity). This is normal and expected operation of the inverter to control the inverter within design parameters. In most cases the alert code 441 notification does not require any additional service or diagnostic procedures. The control sets indoor CFM and outdoor RPM to values according to demand percentage rather than the actual Hz. Possible issue is system running at high pressures. Check for high pressure trips or other alert codes in thermostat and outdoor control. Inverter LEDs will flash code 14. Refer to the unit service documentation for detailed troubleshooting procedures. <p>Inverter flash code 14.</p> <p>The sequence is:</p> <ul style="list-style-type: none"> Red LED: One Flash Green LED: Four Flashes <p>NOTE: Inverter normal operations with no error code present is as follows. Red LED is ON and green LED is OFF.</p>	Automatically clears when the condition no longer exists.
600				Information Only-Dealer	Load Shed Event	<p>Compressor has been cycled OFF on utility load shedding.</p> <ul style="list-style-type: none"> Load shedding function provides a method for a local utility company to limit the maximum power level usage of the outdoor unit. The feature is activated by applying 24VAC power across the L and C terminals on the outdoor control 	Automatically clears when L terminal is inactive.

Table 20. Outdoor Control 7-Segment Display Alert Codes - Compressor

Crankcase Heater, Checkout and Status / Error Codes

Operation:

Crankcase Heater (HR1)

Compressors in all units are equipped with a 40 watt belly-band type crankcase heater. The heater prevents liquid from accumulating in the compressor. The heater is controlled by the crankcase heater thermostat.

Crankcase Heater Thermostat (S40)

Crankcase heater thermostat S40 controls the crankcase heater in all units and is located on the liquid line (see Figure 2 for location).

1. When liquid line temperature drops below 50°F the thermostat closes which results in the heater being energized.
2. When liquid line temperature rises above 70°F the thermostat opens which results in the heater being de-energized.

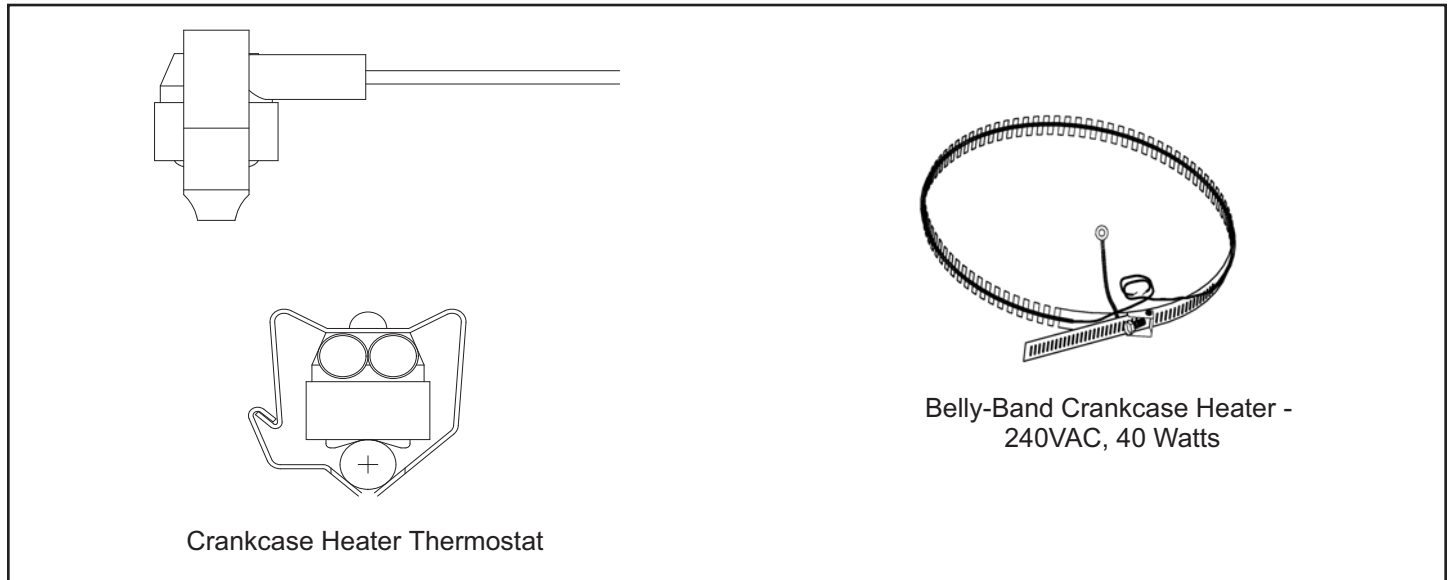

Figure 35. Belly-Band Crankcase Heater Thermostat

Checkout:

Belly-Band Crankcase Heater: Using meter set on ohms, check crankcase heater resistance. If resistance is 0 ohms or infinite, replace the crankcase heater.

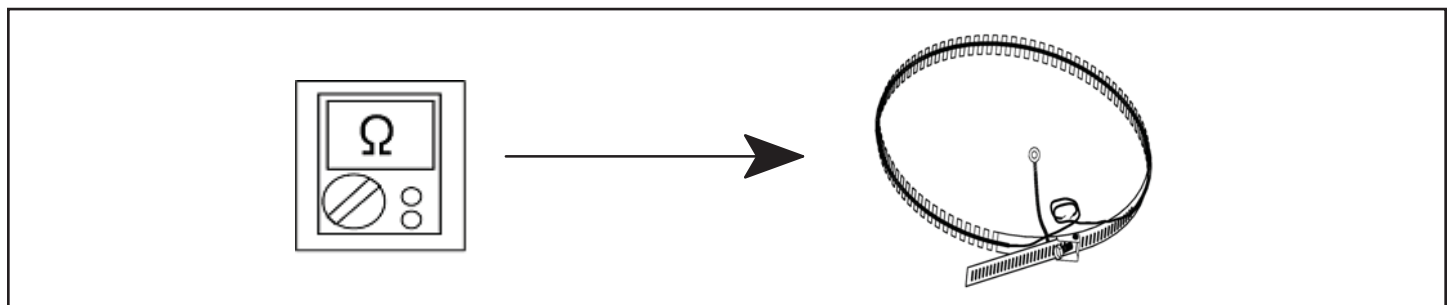

Figure 36. Checking Belly-Band Crankcase Heater

Crankcase Heater Thermostat: As the detected temperature changes, the resistance across the sensor changes. Table 24 on page 79 shows how the resistance varies as the temperature changes for this sensor.

NOTE: When checking the ohms across a sensor, be aware that a sensor showing a resistance value that is not within the range shown in Figure 46, may be performing as designed. However, if a shorted or open circuit is detected, the sensor is faulty; the sensor needs to be replaced.

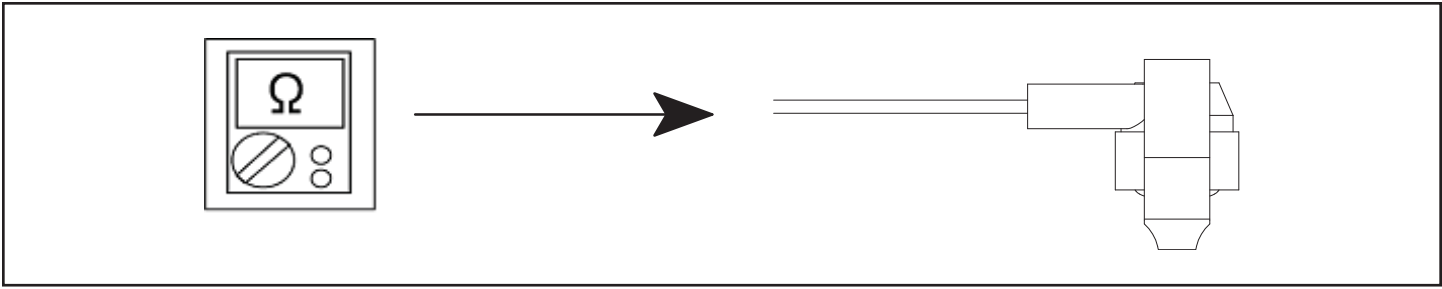

Figure 37. Checking Crankcase Heater Thermostat

Status Code:

None

Error Codes:

None

Compressor Sound Cover

All units come with a soft-sided polyethylene molded outer shell compressor sound cover. The cover helps reduce any unwanted operating sounds from the compressor. The cover features a hook/loop closure system for ease of installation on the compressor.

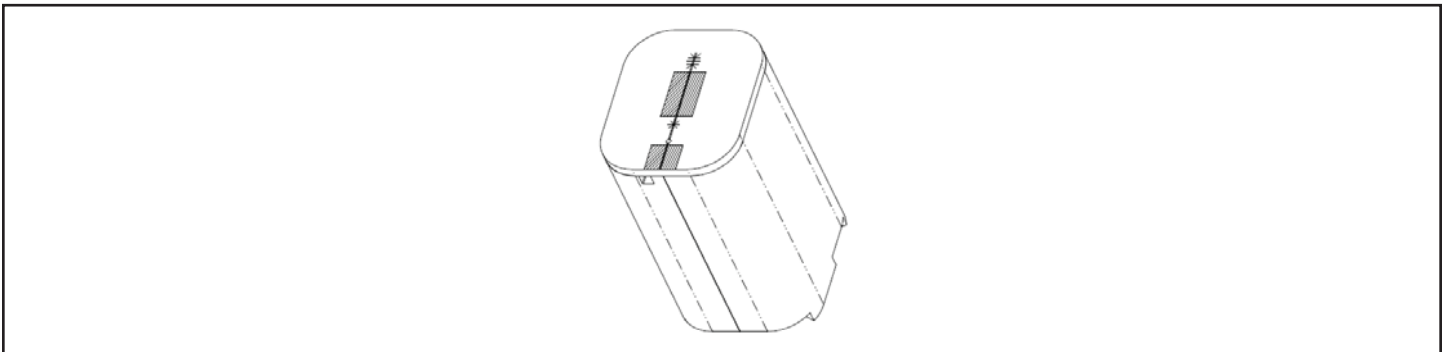

Figure 38. Compressor Sound Cover

Suction Line Filter Drier (Rotary Compressor Models Only)

The NS23A24M, 36M, 48M have a rotary compressor and have a factory installed suction line filter drier installed in the suction line. Liquid drier is not required, but may be field installed. The filter drier is designed to remove moisture and foreign matter, which can lead to compressor failure.

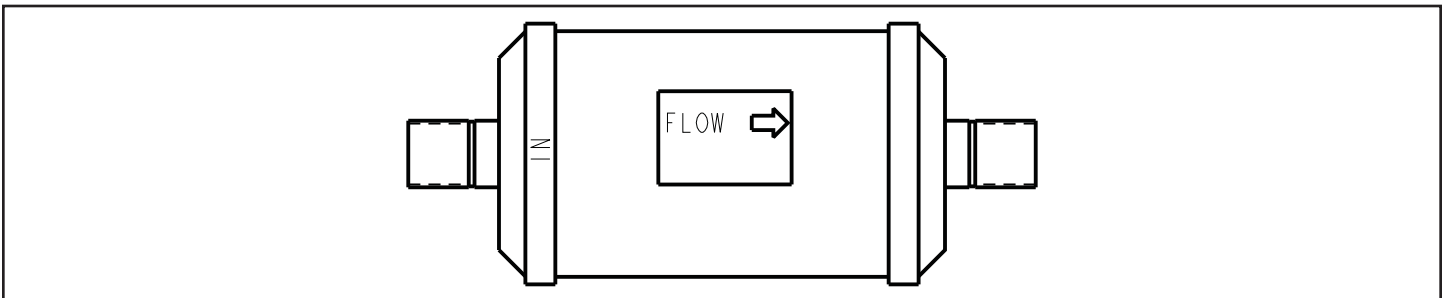

Figure 39. Suction Line Filter Drier

Liquid Line Filter Drier (NS23A60M Scroll compressor model only)

The NS23A60M has a scroll compressor and a liquid line filter drier that is factory-installed in the liquid line. The filter drier is designed to remove moisture and foreign matter, which can lead to compressor failure.

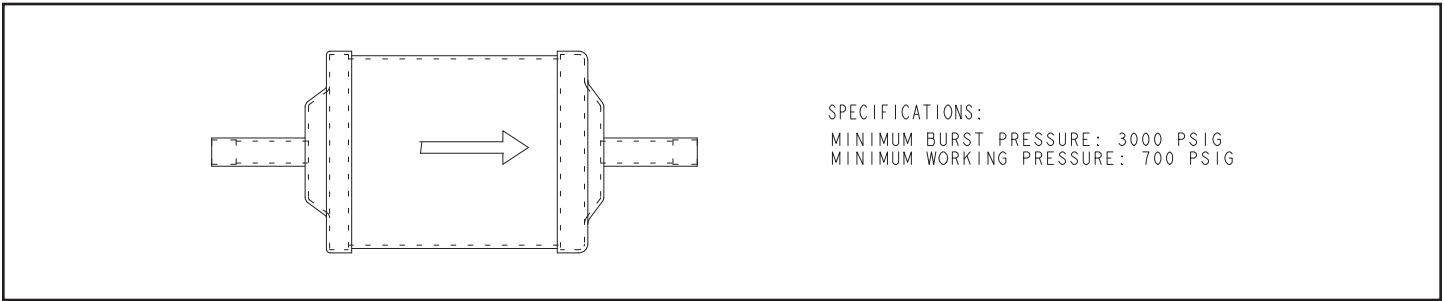

Figure 40. Liquid Line Filter Drier

Top Cap Switch Operation, Checkout and Status / Error Codes

Operation:

Top Cap Thermal Sensor Switch (S173)

Some units are equipped with a compressor-mounted normally closed temperature switch that prevents compressor damage due to overheating caused by internal friction. The switch is located on top of the compressor casing. This switch senses the compressor casing temperature and opens at 239-257°F to shut off compressor operation. The auto-reset switch closes when the compressor casing temperature falls to 151-187°F, and the compressor is re-energized. This is a single-pole, single-throw (SPST) bi-metallic switch.

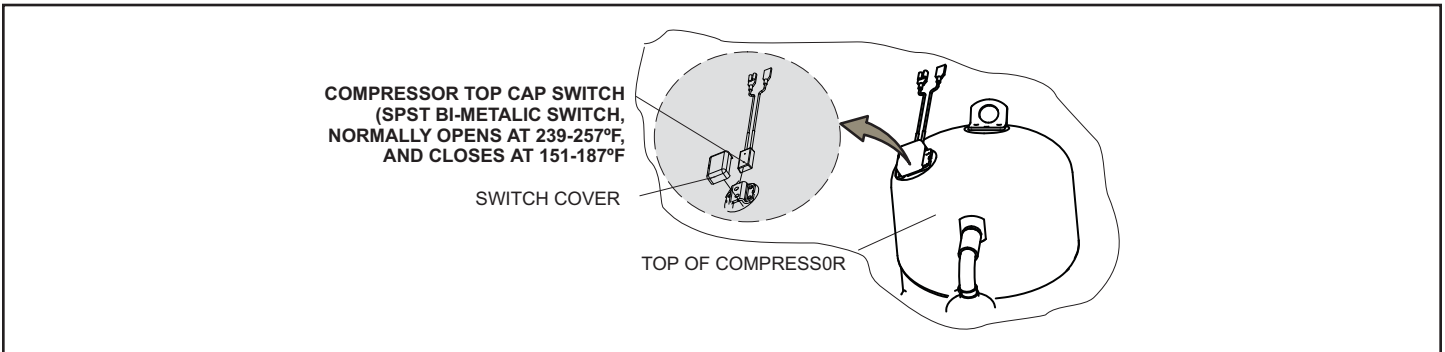

Figure 41. Top Cap Thermal Sensor Switch

Checkout:

Using a multimeter set to ohms, with the terminals disconnected from the system, check the resistance between the two terminals of the top cap switch. If the meter display does not change, the switch is closed. If the meter display goes to infinite, the switch is open.

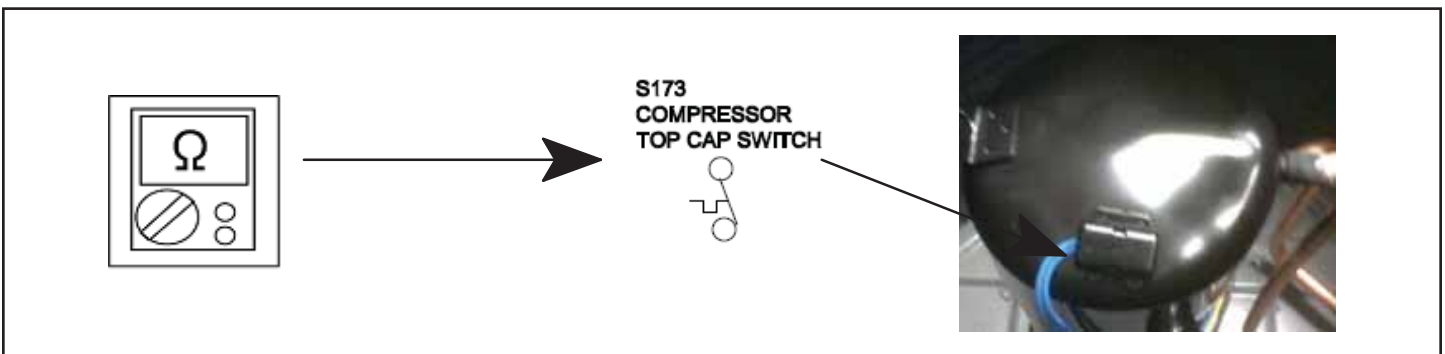

Figure 42. Verifying Top Cap Thermal Sensor Switch

Status:

None

Error:

NOTE: System fault and lockout codes take precedence over system status codes (cooling, heating operating percentages or defrost/dehumidification). Only the latest active fault or lockout codes are displayed (if present). If no fault or lockout codes are active, then system status codes are displayed.

GF= Gas Furnace, AH=Air Handler, ID=Indoor unit (GF or AH), HP=Heat Pump, AC=Air Conditioner, OD=Outdoor Unit (AC or HP), ZA=Zone system and TS=Thermostat

Alert Code	Inverter Flash Code	Priority Condition	Actual Displayed Alert Text	Component or System Operational State and Troubleshooting Tip	How to Clear Alert Code
422		Service Soon	OD Compressor Top Cap Switch Open	Compressor top cap switch exceeding thermal limit. <ul style="list-style-type: none"> • Check condenser fan motor, TXV and indoor unit blower motor. • Check for stuck reversing valve or clogged refrigerant filter. • Check to ensure that one of the wires from the top cap switch has not been disconnected from one of the TP terminals on the outdoor control. Reconnect wire if disconnected. • Check superheat and sub-cooling. 	Automatically clears when error is corrected.
442		Service Urgent	OD Compressor Top Cap Switch Strikes Lockout	The top cap switch has opened five times within one hour. As a result, the outdoor unit is locked out. <ul style="list-style-type: none"> • This condition occurs when compressor thermal protection sensor opens five times within one hour. • Outdoor unit will stop. 	To clear, disconnect power to outdoor unit and restart.

Table 21. Outdoor Control 7-Segment Display Alert Codes - Top Cap Switch

Reactor Operations, Checkout and Status / Error Codes

Operation:

Reactor (Inductor or choke) is a passive two-terminal electrical component that stores energy in its magnetic field. Reactors are one of the basic components used in electronics where current and voltage change with time, due to the ability of inductors to delay and reshape alternating currents.

Checkout:

Main Power ON – Voltage IN reactor should be the same as the voltage OUT. With main power OFF and reactor disconnected from system; resistance between leads should be the same

Status Codes:

None

Error Codes:

None

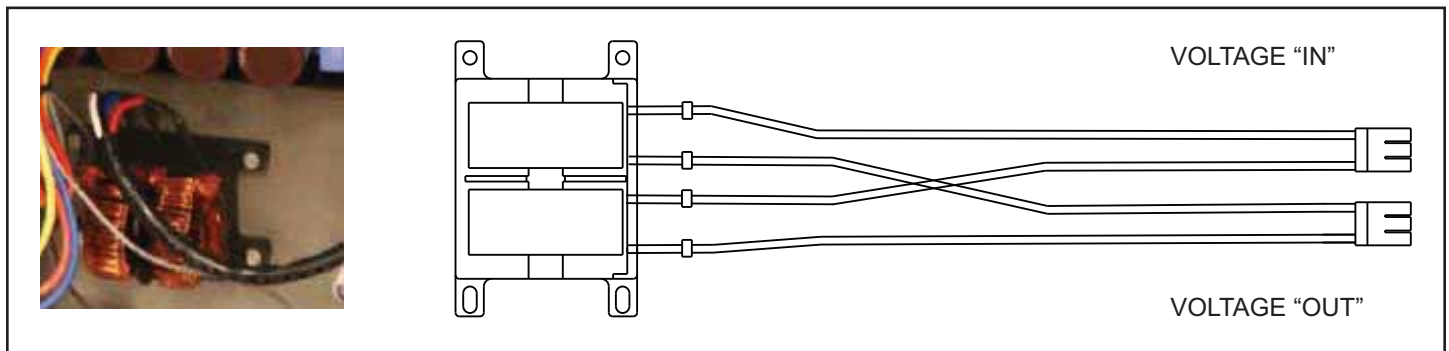

Figure 43. NS23AM Reactor

Outdoor Fan Operation and Checkout

Operation:

NS23AM units have a variable speed ECM fan motor. The variable speed ECM fan motor is controlled by PWM fan output when the compressor is running and will vary the fan speed to match the compressor capacity.

Low Ambient Operation:

The NS23AM units have factory installed low ambient operator that will control the condenser fan motor based upon liquid line temperature.

NS23AM units have a variable speed ECM fan motor. The outdoor control will begin to modulate the outdoor fan motor speed is below 65°F to maintain a liquid line sensor temperature between 58°F and 70°F. If the liquid line sensor drops below 55°F the control will cycle the fan off until liquid temperature rises above 58°F.

Checkout:

VAC Voltage Check

Check for 208/240 VAC power at inverter contactor (red wires) (see Figure 44).

All Units

1. With the unit running, check for 230VAC at the red outdoor fan motor wires at the contactor. If no voltage is present check main power at the contactor.
2. Perform a DC voltage check between the FPWM and Fan C terminal.
3. Using the push button on the control, enter the "fan test mode" in the "field test mode" by pushing and holding the button until solid "-" appears, release the button. Display will start flashing, within 10 seconds, push and hold the button until the "F" symbol displays then release the button. Display will begin to flash "F", within 10 seconds, push and hold the button until it stops flashing, release the button. Outdoor fan motor will cycle on for 10 minutes. To exit, push and hold the button until three horizontal bars display. Release the button and the outdoor fan will cycle off.

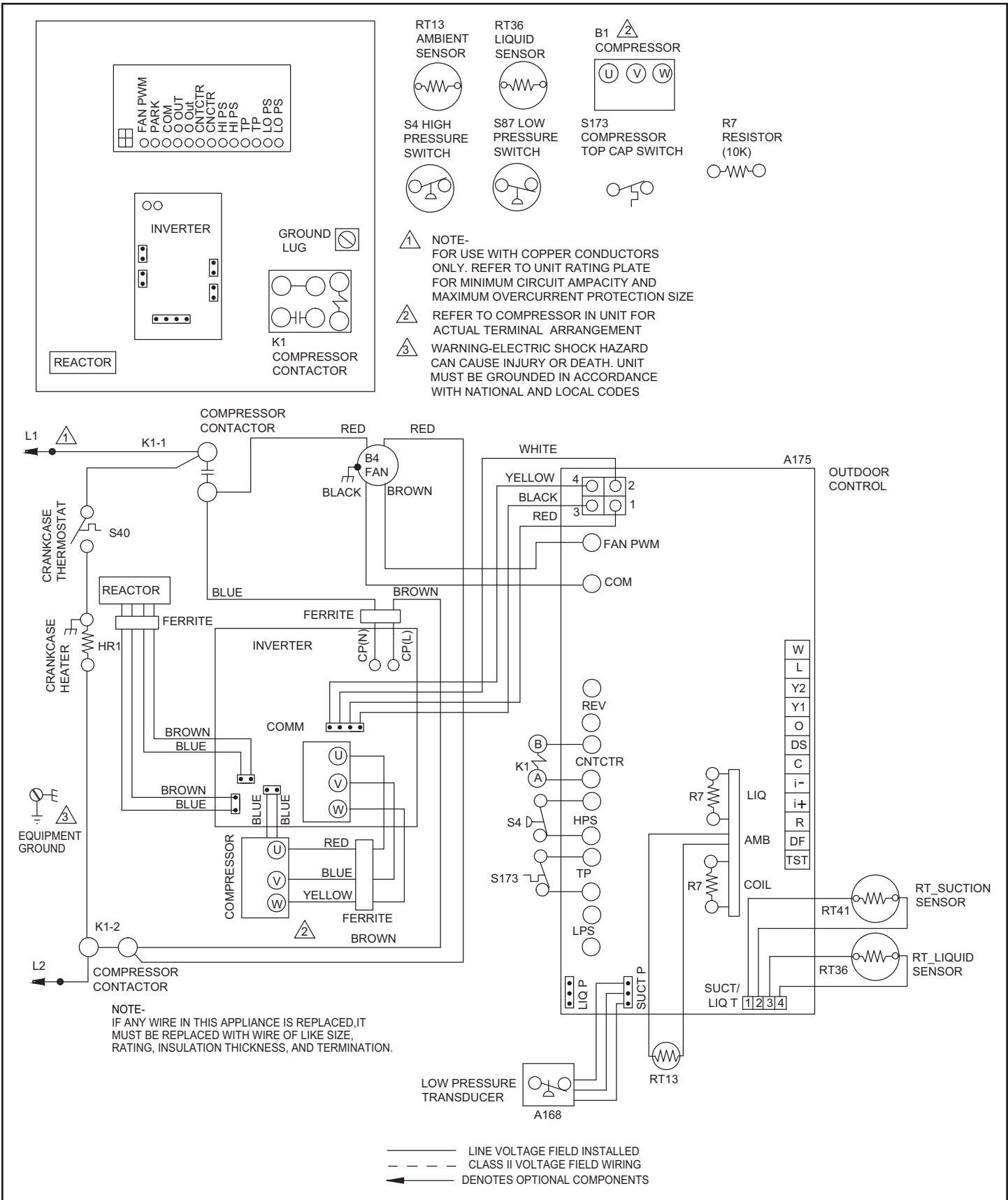

Figure 44. VAC Voltage Check

Outdoor Control Operation, Checkout and Status / Error Codes

Operation:

The outdoor control is a microprocessor-based device for use with variable-capacity compressors up to 5-tons in capacity operating on 24VAC residential power. The outdoor control integrates the functionality of maintaining compressor speed, and outdoor fan control of PSC and ECM motors. The outdoor control is self-configuring. During start-up the outdoor control selects one of two configurations variable-capacity air conditioner or variable-capacity heat pump.

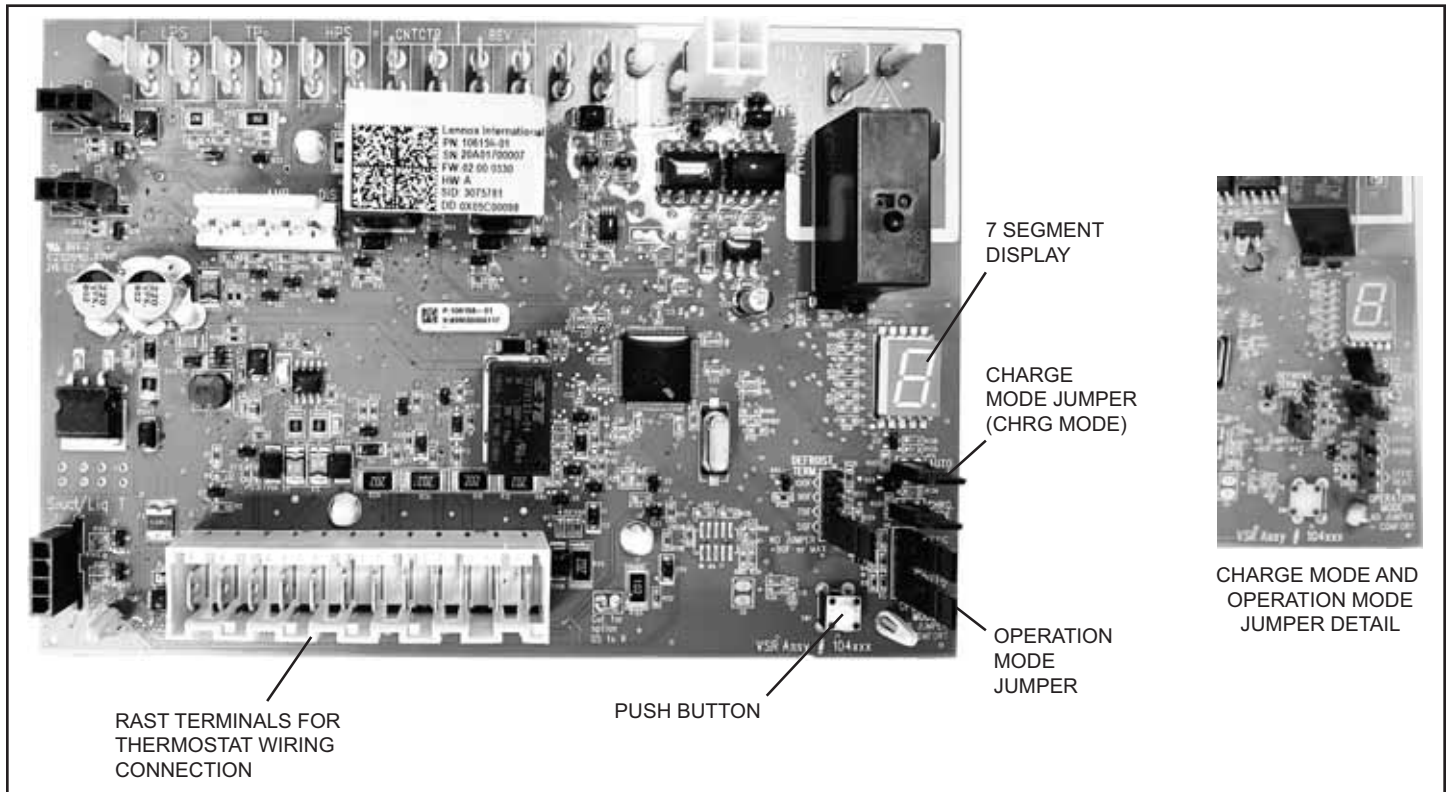

Figure 45. Outdoor Control Unit

Status Codes:

NOTE - System fault and lockout codes take precedence over system status codes (cooling, heating operating percentages or defrost/dehumidification). Only the latest active fault or lockout codes are displayed (if present). If no fault or lockout codes are active, then system status codes are displayed.

GF= Gas Furnace, AH=Air Handler, ID=Indoor unit (GF or AH), HP=Heat Pump, AC=Air Conditioner, OD=Outdoor Unit (AC or HP), ZA=Zone system and TS=Thermostat

Alert Code	Inverter Flash Code	Priority Condition	Actual Displayed Alert Text	Component or System Operational State and Troubleshooting Tip	How to Clear Alert Code
600		Information Only-Dealer	Load Shed Event	Compressor has been cycled OFF on utility load shedding. <ul style="list-style-type: none"> Load shedding function provides a method for a local utility company to limit the maximum power level usage of the outdoor unit. The feature is activated by applying 24VAC power across the L and C terminals on the outdoor control 	Automatically clears when L terminal is inactive.
601		Information Only-Dealer	OD Unit Low Ambient Operational Lockout	<ul style="list-style-type: none"> Outdoor unit has been cycled off on low temperature protection. Outdoor unit will not operate when the outdoor ambient is at or below 4°F (-15.6°C). If the unit is satisfying a demand (running) and the outdoor ambient drops below 4°F (-15.6°C), the unit will continue to operate until the demand has been satisfied or the outdoor ambient drops to 15°F (-9.4°C) which will result in the unit being locked out (shut down). 	Automatically clears when low temperature condition no longer exists.

Table 22. Outdoor Control 7-Segment Display Alert Codes - Outdoor Control Status

Error Codes:

NOTE - System fault and lockout codes take precedence over system status codes (cooling, heating operating percentages or defrost/dehumidification). Only the latest active fault or lockout codes are displayed (if present). If no fault or lockout codes are active, then system status codes are displayed.

GF= Gas Furnace, AH=Air Handler, ID=Indoor unit (GF or AH), HP=Heat Pump, AC=Air Conditioner, OD=Outdoor Unit (AC or HP), ZA=Zone system and TS=Thermostat							
Alert Code	Inverter Code	Inverter Flash Code		Priority Condition	Actual Displayed Alert Text	Component or System Operational State and Troubleshooting Tip	How to Clear Alert Code
		Red LED	Green LED				
105		N/A	N/A	Service Urgent	Communication Problem	<p>One of the system components has lost communication with the system. The system component (device) is unable to communicate.</p> <ul style="list-style-type: none"> A3 - Access dealer control center, select notifications icon, review alert code details to determine which device or unit has the communication problem. Review both active and cleared alerts. Zoning - Remove wire from Smart Hub to Comfort Sync® control and just have wiring from furnace. <p>Troubleshooting:</p> <ul style="list-style-type: none"> Check each control for additional codes In most cases issues are related to electrical noise. Verify that high voltage power is separated from the low voltage communication wires. Check for proper grounding on line voltage and low voltage wiring, transformer and equipment. Check for incorrectly wired or loose or spliced connections between system components (devices or units). Make sure all unused wires are tied together and taken back to the C terminal on the indoor control board as shown in the installation and setup guide. Disconnect all wiring to other system components (except thermostat to indoor unit) and reconnect one device at a time and recommission system each time a device is reconnected until the issue is located. Float Switch: When using a float switch, use isolation relay to break common wire to outdoor unit. For testing purposes, remove float switch from the circuit. Firmware and Accessories: Make sure that Smart Hub has correct firmware version for added accessory. If software is not updated in system it will cause system operation issues. Inductive voltage from surrounding sources. Check each wire in AC mode to C on circuit board. <ul style="list-style-type: none"> > Good voltage is .03-.3VAC inductive voltage is not an issue. > Acceptable can be up to .7VAC with moderate success. > Some units have worked with up to 1.2VAC with occasional success. > Voltage over 1.2VAC needs to be addressed. 	Automatically clears when the system detects the issue no longer exists.
120		N/A	N/A	Service Soon	Unresponsive Device	<p>There is a delay in the system component responding to the system. Typically this alert code does not cause any operational issues and will clear on its own.</p> <ul style="list-style-type: none"> This alert code is usually caused by a delay in the outdoor unit responding to the thermostat. Leaking voltage from strands within the bundle. <ul style="list-style-type: none"> > Land only the R wire on the R terminal to load the bundle with 24VAC. <ul style="list-style-type: none"> ▶ Typically only the R wire needs to be landed to identify if voltage is leaking. ▶ If voltage is present checking the other wires is informational only but not needed. ▶ If voltage is not present checking the other wires one at a time would be needed. > Check each loose wire in AC mode to C on circuit board. <ul style="list-style-type: none"> ▶ Good voltage is .03-.3VAC leaking voltage is not the issue. ▶ Acceptable can be up to .7VAC with moderate success. ▶ Some units have worked with up to 1.2VAC with occasional success. ▶ Voltage over 1.2VAC needs to be addressed. 	Automatically clears after an unresponsive system component (device) responds to any inquiry.

Table 23. Outdoor Control 7-Segment Display Alert Codes - Outdoor Control Errors

NOTE - System fault and lockout codes take precedence over system status codes (cooling, heating operating percentages or defrost/dehumidification). Only the latest active fault or lockout codes are displayed (if present). If no fault or lockout codes are active, then system status codes are displayed.

GF= Gas Furnace, AH=Air Handler, ID=Indoor unit (GF or AH), HP=Heat Pump, AC=Air Conditioner, OD=Outdoor Unit (AC or HP), ZA=Zone system and TS=Thermostat

Alert Code	Inverter Code	Inverter Flash Code		Priority Condition	Actual Displayed Alert Text	Component or System Operational State and Troubleshooting Tip	How to Clear Alert Code
		Red LED	Green LED				
124		N/A	N/A	Service Urgent	Tstat Lost Communication To Smarthub	<p>The thermostat has lost communication with a system component for more than three minutes. System component has lost communication with the thermostat.</p> <ul style="list-style-type: none"> • Check the wiring connections between components. • Ohm wires. • Cycle power. • Any component that is miss-wired may cause a false component code to be shown on system component. • Disconnect all wiring to other system components and check communication one at a time. <p>NOTE: When using a float switch, use isolation relay to break common wire to outdoor unit. For testing purposes, remove float switch from the circuit</p> <p>This alert code stops all associated system operations and waits for a heartbeat message from the system component that is not communicating.</p>	Automatically clears after communication is re-established with applicable system component (device).
125				Service Urgent	Control Hardware Problem	<p>There is a hardware problem on a system component control. There is a control hardware problem.</p> <p>Replace the control if the problem prevents operation and is persistent.</p>	Automatically clears five minutes after the issue no longer exists.
132				Service Urgent	Device Control Software Fault	<p>System component control software is corrupted.</p> <ul style="list-style-type: none"> • Recycle power. • If failure re-occurs, replace the system component control. 	Manual system power reset is required to recover from this alert code.

Table 23. Outdoor Control 7-Segment Display Alert Codes - Outdoor Control Errors

Unit Sensor Operation, Checkout and Status /Error Codes

Operation:

6-Pin Sensor Harness (DIS, AMB, COIL)

Discharge Sensor (R7 - No Sensor)

There is no sensor located on positions 5 and 6 of the connector. A 10K Ohm resistor installed between pins 5 and 6 on the cable harness provides continuity for this circuit.

Ambient Temperature Sensor (RT13)

Ambient temperatures, as read by the ambient temperature sensor connected to pin 3 and pin 4, which are below -35°F (-37°C) or above 120°F (48°C) trigger a fault condition. If the ambient sensor is open, shorted, or out of the temperature range of the sensor, the control displays the appropriate alert code. Heating and cooling operation is allowed in this fault condition

Coil Temperature Sensor (R7 - No Sensor)

There is no sensor located on position 1 to position 2 of the connector. A 10K ohm resistor is installed between pins 1 and 2 on the cable harness and provides continuity for this circuit.

4-Pin Suction Temperature Sensor / Liquid Temperature Sensor Harness

Suction Line Sensor (RT41)

Suction line temperature is read by the suction line temperature sensor between Pins 1 and Pin 2 of the 4-pin sensor harness. Nominal Resistance of the sensor is 10K ohms at 77F. The control will display are E182 error code if the sensor reads open or shorted for 24 hours. Cooling operation is allowed with this fault.

Liquid Line Temperature Sensor (RT36)

Liquid line temperature is read by the liquid line temperature sensor between Pins 3 and Pin 4 of the 4-pin sensor harness. Nominal Resistance of the sensor is 10K ohms at 77F. The control will display are E184 error code if the sensor reads open or shorted for 24 hours. Cooling operation is allowed with this fault.

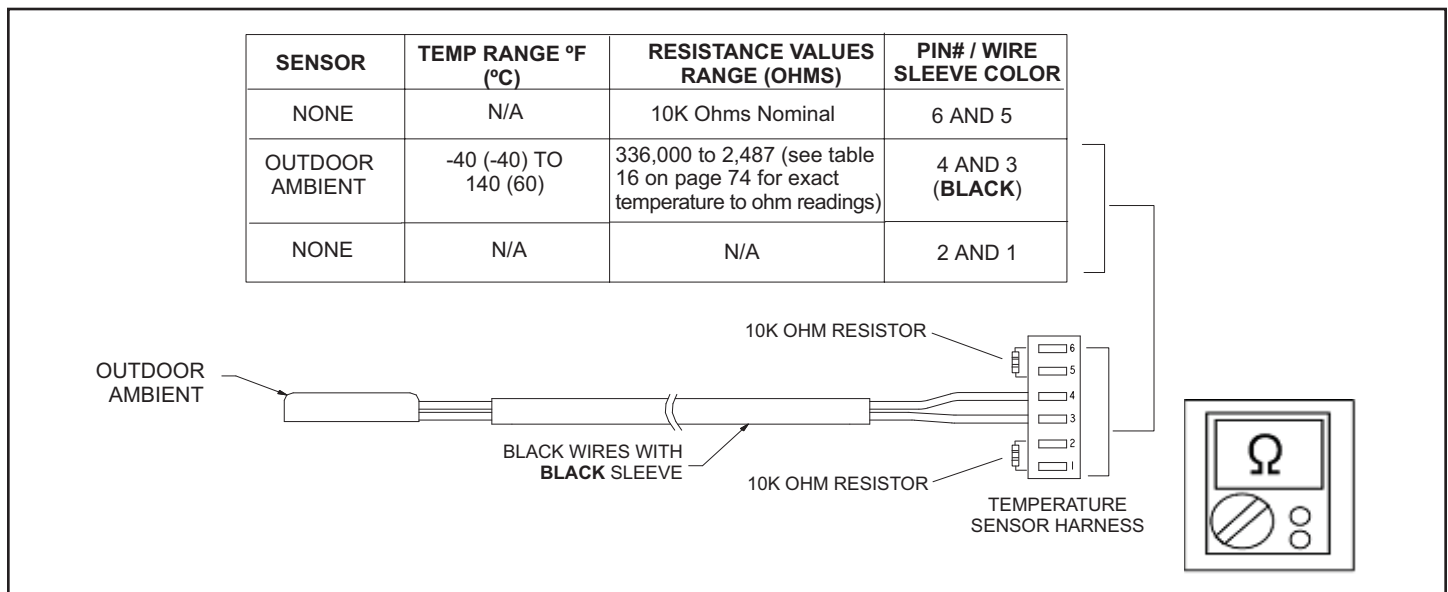

Figure 46. Temperature Sensor Specification

Checkout:

Sensors connect to the outdoor control through a field-replaceable harness assembly that plugs into the outdoor control. Through the sensors, the control detects outdoor ambient, coil and liquid temperature fault conditions. As the detected temperature changes, the resistance across the sensor changes. Check sensor operation by reading ohms across pins shown in Figure 47.

NOTE: When checking the ohms across a sensor, be aware that a sensor showing a resistance value that is not within the range shown in Figure 46, may be performing as designed. However, if a shorted or open circuit is detected, then the sensor may be faulty and the sensor harness will need to be replaced.

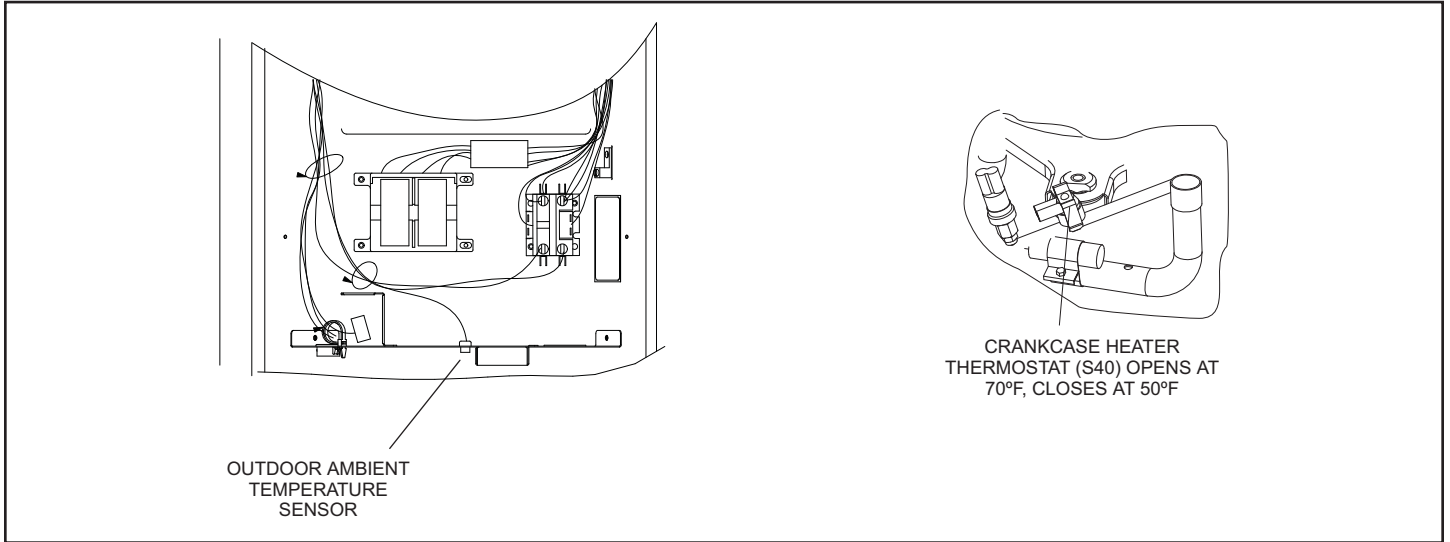

Figure 47. Temperature Sensor Locations

Degree Fahrenheit	Resistance	Degree Fahrenheit	Resistance	Degree Fahrenheit	Resistance	Degree Fahrenheit	Resistance
136.3	2680	56.8	16657	21.6	44154	-11.3	123152
133.1	2859	56.0	16973	21.0	44851	-11.9	125787
130.1	3040	55.3	17293	20.5	45560	-12.6	128508
127.3	3223	54.6	17616	20.0	46281	-13.2	131320
124.7	3407	53.9	17942	19.4	47014	-13.9	134227
122.1	3592	53.2	18273	18.9	47759	-14.5	137234
119.7	3779	52.5	18607	18.4	48517	-15.2	140347
117.5	3968	51.9	18945	17.8	49289	-15.9	143571
115.3	4159	51.2	19287	17.3	50074	-16.5	146913
113.2	4351	50.5	19633	16.8	50873	-17.2	150378
111.2	4544	49.9	19982	16.3	51686	-17.9	153974
109.3	4740	49.2	20336	15.7	52514	-18.6	157708
107.4	4937	48.5	20695	15.2	53356	-19.3	161588
105.6	5136	47.9	21057	14.7	54215	-20.1	165624
103.9	5336	47.3	21424	14.1	55089	-20.8	169824
102.3	5539	46.6	21795	13.6	55979	-21.5	174200
100.6	5743	46.0	22171	13.1	56887	-22.3	178762
99.1	5949	45.4	22551	12.5	57811	-23.0	183522
97.6	6157	44.7	22936	12.0	58754	-23.8	188493
96.1	6367	44.1	23326	11.5	59715	-24.6	193691
94.7	6578	43.5	23720	11.0	60694	-25.4	199130
93.3	6792	42.9	24120	10.4	61693	-26.2	204829
92.0	7007	42.3	24525	9.9	62712	-27.0	210805
90.6	7225	41.7	24934	9.3	63752	-27.8	217080
89.4	7444	41.1	25349	8.8	64812	-28.7	223677
88.1	7666	40.5	25769	8.3	65895	-29.5	230621
86.9	7890	39.9	26195	7.7	67000	-30.4	237941
85.7	8115	39.3	26626	7.2	68128	-31.3	245667
84.5	8343	38.7	27063	6.7	69281	-32.2	253834
83.4	8573	38.1	27505	6.1	70458	-33.2	262482
82.3	8806	37.5	27954	5.6	71661	-34.1	271655
81.2	9040	37.0	28408	5.0	72890	-35.1	281400
80.1	9277	36.4	28868	4.5	74147	-36.1	291774
79.0	9516	35.8	29335	3.9	75431	-37.1	302840
78.0	9757	35.2	29808	3.4	76745	-38.2	314669
77.0	10001	34.7	30288	2.8	78090	-39.2	327343
76.0	10247	34.1	30774	2.3	79465		
75.0	10496	33.5	31267	1.7	80873		
74.1	10747	33.0	31766	1.2	82314		
73.1	11000	32.4	32273	0.6	83790		
72.2	11256	31.9	32787	0.0	85302		
71.3	11515	31.3	33309	-0.5	86852		
70.4	11776	30.7	33837	-1.1	88440		
69.5	12040	30.2	34374	-1.7	90068		
68.6	12306	29.6	34918	-2.2	91738		
67.7	12575	29.1	35471	-2.8	93452		
66.9	12847	28.6	36031	-3.4	95211		
66.0	13122	28.0	36600	-4.0	97016		
65.2	13400	27.5	37177	-4.6	98870		
64.4	13681	26.9	37764	-5.2	100775		
63.6	13964	26.4	38359	-5.7	102733		
62.8	14251	25.8	38963	-6.3	104746		
62.0	14540	25.3	39577	-6.9	106817		
61.2	14833	24.8	40200	-7.5	108948		
60.5	15129	24.2	40833	-8.2	111141		
59.7	15428	23.7	41476	-8.8	113400		
59.0	15730	23.2	42130	-9.4	115727		
58.2	16036	22.6	42794	-10.0	118126		
57.5	16345	22.1	43468	-10.6	120600		

Table 24. Ambient and Liquid Line Sensors Temperature / Resistance Range

Error Codes:

NOTE - System fault and lockout codes take precedence over system status codes (cooling, heating operating percentages or defrost/dehumidification). Only the latest active fault or lockout codes are displayed (if present). If no fault or lockout codes are active, then system status codes are displayed.

GF= Gas Furnace, AH=Air Handler, ID=Indoor unit (GF or AH), HP=Heat Pump, AC=Air Conditioner, OD=Outdoor Unit (AC or HP), ZA=Zone system and TS=Thermostat

Alert Code	Inverter Code	Inverter Flash Code		Priority Condition	Actual Displayed Alert Text	Component or System Operational State and Troubleshooting Tip	How to Clear Alert Code
		Red LED	Green LED				
180				Service Soon	Outdoor Temperature Sensor Problem	<p>The thermostat has found a problem with the outdoor sensor in the outdoor unit or the optional outdoor sensor connected to the indoor unit. In normal operation after system component control recognizes sensors, the alert code will be sent if valid temperature reading is lost.</p> <ul style="list-style-type: none"> Compare outdoor sensor resistance to temperature / resistance charts in unit installation instructions. Replace sensor pack or stand alone outdoor sensor. At the beginning of (any) configuration, furnace, air-handler control or equipment interface module will detect the presence of the sensor(s). If detected (reading in range), appropriate feature will be set as 'installed' and shown in the 'About' screen. 	Automatically clears upon configuration, or sensing normal values.
182				Service Soon	OD Suction Temperature Sensor Fault	<ul style="list-style-type: none"> Reading below 0.25V or above 4.75V for 24hrs +/- 3hrs. System will continue to operate normally. 	Resets after 3 consecutive readings that are in range.
424				Service Soon	OD Liquid Line Sensor Faulty	<p>The liquid line temperature sensor has malfunctioned.</p> <ul style="list-style-type: none"> In normal operation after outdoor control recognizes sensors, the alert code will be sent if a valid temperature reading is lost. Compare liquid line sensor resistance to temperature / resistance charts in unit installation instructions. Replace sensor pack if necessary. At the beginning of (any) configuration, furnace or air handler control will detect the presence of the sensor(s). If detected (reading in range), appropriate feature will be set as 'installed' and shown in the thermostat 'About' screen. 	Automatically clears upon configuration, or sensing normal values.

Table 25. Outdoor Control 7-Segment Display Alert Codes – Outdoor Control Errors

DC Inverter Control Operation, Checkout, Status / Error Codes

Operation Of Components:

Electromagnetic compatibility circuit (EMC): EMC ensures the correct operation of different equipment items which use or respond to electromagnetic phenomena. It also helps to negate the effects of interference.

Converter:

Converts AC (alternating current) to DC (direct current).

Power Factor Correction (PFC) Circuit:

The PFC module is an integrated part of the outdoor inverter that monitors the DC bus for high, low and abnormal voltage conditions. If any of these conditions are detected, the PFC function and compressor will stop.

Intelligent (Inverter) Power Module (IPM):

The IPM converts DC power into AC power. The control method is known as pulse width modulation (PWM). This means the DC is switched on and off very quickly (chopped) by the transistor switches to make simulated AC at required frequency and voltage.

Communication Control Circuit:

Receives and sends message between the inverter and the outdoor control.

Status Codes:

NOTE - System fault and lockout codes take precedence over system status codes (cooling, heating operating percentages or defrost/dehumidification). Only the latest active fault or lockout codes are displayed (if present). If no fault or lockout codes are active, then system status codes are displayed.

GF= Gas Furnace, AH=Air Handler, ID=Indoor unit (GF or AH), HP=Heat Pump, AC=Air Conditioner, OD=Outdoor Unit (AC or HP), ZA=Zone system and TS=Thermostat

Alert Code	Inverter Code	Inverter Flash Code		Priority Condition	Actual Displayed Alert Text	Component or System Operational State and Troubleshooting Tip	How to Clear Alert Code
		Red LED	Green LED				
N/A	N/A	ON	OFF	N/A	NS23A36M only: Indicates inverter is operating normally.		
N/A	N/A	ON	ON	N/A	NS23A60M only: Indicates inverter is operating normally.		
N/A	N/A	OFF	OFF	N/A	Indicates inverter is NOT energized.		

Table 26. Outdoor Control 7-Segment Display Alert Codes and Inverter LED Flash Codes

Error Codes:

NOTE - System fault and lockout codes take precedence over system status codes (cooling, heating operating percentages or defrost/dehumidification). Only the latest active fault or lockout codes are displayed (if present). If no fault or lockout codes are active, then system status codes are displayed.

GF= Gas Furnace, AH=Air Handler, ID=Indoor unit (GF or AH), HP=Heat Pump, AC=Air Conditioner, OD=Outdoor Unit (AC or HP), ZA=Zone system and TS=Thermostat

Alert Code	Inverter Code	Inverter Flash Code		Priority Condition	Actual Displayed Alert Text	Component or System Operational State and Troubleshooting Tip	How to Clear Alert Code
		Red LED	Green LED				
423	40	4 flashes	OFF	Service Soon/ Service Urgent	OD Inverter CT Circuit Fault	<p>The inverter has detected a circuit issue.</p> <ul style="list-style-type: none"> When this condition is detected the outdoor control will stop outdoor unit operations and start the anti-short cycle timer – moderate condition. Outdoor control will lockout unit after 10 strikes within an hour – critical condition. Inverter LEDs will flash code 40 Refer to the unit service documentation for troubleshooting procedures. <p>Inverter flash code 40:</p> <p>The sequence is: Red LED: Four Flashes Green LED: Off</p> <p>NOTE: Inverter normal operations with no error code present is as follows. Red LED is ON and Green LED is OFF.</p>	<p>A moderate alert code will clear automatically when the inverter detects the condition no longer exist and will send a clear alert code message.</p> <p>To clear critical alert code disconnect power to outdoor unit and restart.</p>
426				Service Urgent	OD Excessive Inverter Alarms	<p>After 10 faults within 60 consecutive minutes, the control will lockout. Inverter will flash codes 12 to 14 and 53.</p> <p>NOTE: These inverter codes do not count towards this lockout condition.</p>	<p>To clear disconnect power to outdoor control and restart.</p>

Table 27. Outdoor Control 7-Segment Display Alert Codes and Inverter LED Flash Codes

NOTE - System fault and lockout codes take precedence over system status codes (cooling, heating operating percentages or defrost/dehumidification). Only the latest active fault or lockout codes are displayed (if present). If no fault or lockout codes are active, then system status codes are displayed.

GF= Gas Furnace, AH=Air Handler, ID=Indoor unit (GF or AH), HP=Heat Pump, AC=Air Conditioner, OD=Outdoor Unit (AC or HP), ZA=Zone system and TS=Thermostat

Alert Code	Inverter Code	Inverter Flash Code		Priority Condition	Actual Displayed Alert Text	Component or System Operational State and Troubleshooting Tip	How to Clear Alert Code
		Red LED	Green LED				
427	21	2 flashes	1 flash	Service Soon/ Service Urgent	OD Inverter DC Peak Fault	<p>The inverter has detected a DC peak fault condition.</p> <ul style="list-style-type: none"> If condition (55A or higher) is detected, outdoor unit will stop (compressor and fan) – moderate condition. Anti-short cycle is initiated. If peak current (55A or higher) occurs 10 times within an hour, system will lockout – critical condition. Inverter LEDs will flash code 21. If the unit is a variable capacity heat pump, this error may occur entering or exiting a defrost cycle as the compressor restarts after the 30 second compressor shift delay. If the unit was manufactured prior to serial number 5817F and has frequent alert code 427, then compare the inverter part number to the latest part number listed in the unit repair parts. Units produced after serial number 5817F which is listed on the unit name plate have an inverter with updated software that includes compressor current slope logic to reduce the potential of alert code 427 instances from occurring during defrost. Replace the inverter with the latest inverter if necessary. Refer to the unit service documentation for detailed troubleshooting procedures. <p>NOTE: Serial number format on unit name plate is PPYYMNNNNN (PP = Manufacturing Plant, YY and M represents the year and month made).</p> <p>Inverter flash code 21.</p> <p>The sequence is:</p> <ul style="list-style-type: none"> Red LED: Two Flashes Green LED: One Flash <p>NOTE: Inverter normal operations with no error code present is as follows. Red LED is ON and Green LED is OFF.</p>	To clear, disconnect and reconnect power to outdoor control.
428	22	2 flashes	2 flashes	Service Soon/ Service Urgent	OD Inverter High Main Input Current	<p>The inverter has detected a high main input current condition.</p> <ul style="list-style-type: none"> If condition is detected, outdoor unit will stop (compressor and fan) – moderate condition. Anti-short cycle is initiated. If condition occurs 10 times within an hour, system will lockout – critical condition. Inverter LEDs will flash code 22. Refer to the unit service documentation for detailed troubleshooting procedures. <p>Inverter flash code 22.</p> <p>The sequence is:</p> <ul style="list-style-type: none"> Red LED: Two Flashes Green LED: Two Flashes <p>NOTE: Inverter normal operations with no error code present is as follows. Red LED is ON and Green LED is OFF.</p>	To clear, disconnect power to outdoor unit and restart.

Table 27. Outdoor Control 7-Segment Display Alert Codes and Inverter LED Flash Codes

NOTE - System fault and lockout codes take precedence over system status codes (cooling, heating operating percentages or defrost/dehumidification). Only the latest active fault or lockout codes are displayed (if present). If no fault or lockout codes are active, then system status codes are displayed.

GF= Gas Furnace, AH=Air Handler, ID=Indoor unit (GF or AH), HP=Heat Pump, AC=Air Conditioner, OD=Outdoor Unit (AC or HP), ZA=Zone system and TS=Thermostat

Alert Code	Inverter Code	Inverter Flash Code		Priority Condition	Actual Displayed Alert Text	Component or System Operational State and Troubleshooting Tip	How to Clear Alert Code
		Red LED	Green LED				
429	23	2 flashes	3 flashes	Service Soon/ Service Urgent	OD Inverter DC Link Low Voltage	<p>The inverter has detected a DC link low voltage condition.</p> <ul style="list-style-type: none"> On a call for compressor operation, if DC link power in inverter does not rise above 180 VDC for 2- and 3-ton models, 250 VDC for 4- and 5-ton models within 30 seconds, the control will display a moderate code. If condition is detected, outdoor unit will stop (compressor and fan) – moderate condition. An anti-short cycle timer is initiated. If condition occurs 10 times within a 60 consecutive minutes, system will lock out and display alert code 429 – critical condition. The outdoor control anti-short cycle timer will time out and the unit will recycle the demand. Inverter LEDs will flash code 23. Refer to the unit service documentation for detailed troubleshooting procedures. Perform test function and verify inverter DC link and line input voltage and current. Also check input to filter board and reactor before replacing inverter board. <p>Inverter flash code 23.</p> <p>The sequence is:</p> <ul style="list-style-type: none"> Red LED: Two Flashes Green LED: Three Flashes <p>NOTE: Inverter normal operations with no error code present is as follows. Red LED is ON and Green LED is OFF.</p> <p>Troubleshooting Suggestions:</p> <ul style="list-style-type: none"> Check wire connections (U, V and W) at inverter plug in harness and compressor. Check the resistance of compressor windings. If not in range, replace compressor. Check compressor to ground. If ground issue, replace compressor. Check input power (Single Phase - 208/230VAC ± 10%. If out of range, correct main power issue. Check DC Link voltage and MICOM Sensing voltage. If out of range, replace inverter. if okay, possible mechanical issue with compressor. <p>Go to outdoor unit service manual for detail troubleshooting procedures and require values for testing DC link voltages and various insulation resistance characteristics.</p>	Automatically clears when the system detects that the issue no longer exists.
430	26	2 flashes	6 flashes	Service Soon/ Service Urgent	OD Inverter Compressor Startup Fail	<p>Compressor start-up failure.</p> <ul style="list-style-type: none"> If condition is detected, outdoor unit will stop (compressor and fan) – moderate condition. Anti-short cycle is initiated. If condition occurs 10 times within 60 consecutive minutes, the system will lockout – critical condition. Inverter LEDs will flash code 26. Refer to the unit service documentation for detailed troubleshooting procedures. <p>Inverter flash code 26.</p> <p>The sequence is:</p> <ul style="list-style-type: none"> Red LED: Two Flashes Green LED: Six Flashes <p>NOTE: Inverter normal operations with no error code present is as follows. Red LED is ON and Green LED is OFF.</p> <ul style="list-style-type: none"> Check refrigerant Replace outdoor control board Replace inverter. 	To clear, disconnect power to outdoor unit and restart.

Table 27. Outdoor Control 7-Segment Display Alert Codes and Inverter LED Flash Codes

NOTE - System fault and lockout codes take precedence over system status codes (cooling, heating operating percentages or defrost/dehumidification). Only the latest active fault or lockout codes are displayed (if present). If no fault or lockout codes are active, then system status codes are displayed.

GF= Gas Furnace, AH=Air Handler, ID=Indoor unit (GF or AH), HP=Heat Pump, AC=Air Conditioner, OD=Outdoor Unit (AC or HP), ZA=Zone system and TS=Thermostat

Alert Code	Inverter Code	Inverter Flash Code		Priority Condition	Actual Displayed Alert Text	Component or System Operational State and Troubleshooting Tip	How to Clear Alert Code
		Red LED	Green LED				
431	27	2 flashes	7 flashes	Service Soon/ Service Urgent	OD Inverter PFC Fault	<p>The inverter has detected a PFC circuit over-current condition.</p> <ul style="list-style-type: none"> • Error occurs when PFC detects an over current condition of 100A peak. • If condition is detected, outdoor unit will stop (compressor and fan) – moderate condition. • Anti-short cycle timer is initiated. • If condition occurs 10 times within 60 consecutive minutes, the system will lockout – critical condition. • Inverter LEDs will flash code 27. • Refer to the unit service documentation for detailed troubleshooting procedures. <p>Inverter flash code 27.</p> <p>The sequence is:</p> <ul style="list-style-type: none"> • Red LED: Two Flashes • Green LED: Seven Flashes <p>NOTE: Inverter normal operations with no error code present is as follows. Red LED is ON and Green LED is OFF.</p>	To clear, disconnect power to outdoor unit and restart.
432	28	2 flashes	8 flashes	Service Soon/ Service Urgent	OD Inverter DC Link High Voltage	<p>The inverter has detected a DC link high voltage condition.</p> <ul style="list-style-type: none"> • Error occurs when the DC link capacitor voltage is greater than 480 VDC. • If condition is detected, outdoor unit will stop (compressor and fan) – moderate condition. • Anti-short cycle timer is initiated. • If condition occurs 10 times within 60 consecutive minutes, the system will lockout – critical condition. • Inverter LEDs will flash code 28. • Refer to the unit service documentation for detailed troubleshooting procedures. <p>Inverter flash code 28.,</p> <p>The sequence is:</p> <ul style="list-style-type: none"> • Red LED: Two Flashes • Green LED: Eight Flashes <p>NOTE: Inverter normal operations with no error code present is as follows. Red LED is ON and Green LED is OFF.</p> <p>Troubleshooting Suggestions:</p> <ul style="list-style-type: none"> • Check wire connections (U, V and W) at inverter plug in harness and compressor. • Check the resistance of compressor windings. If not in range, replace compressor. • Check compressor to ground. If ground issue, replace compressor. • Check input power (Single Phase - 208/230VAC ± 10%. If out of range, correct main power issue. • Check DC Link voltage and MICOM Sensing voltage. If out of range, replace inverter. if okay, possible mechanical issue with compressor. <p>Go to outdoor unit service manual for detail troubleshooting procedures and require values for testing DC link voltages and various insulation resistance characteristics.</p>	To clear, disconnect power to outdoor unit and restart.

Table 27. Outdoor Control 7-Segment Display Alert Codes and Inverter LED Flash Codes

NOTE - System fault and lockout codes take precedence over system status codes (cooling, heating operating percentages or defrost/dehumidification). Only the latest active fault or lockout codes are displayed (if present). If no fault or lockout codes are active, then system status codes are displayed.

GF= Gas Furnace, AH=Air Handler, ID=Indoor unit (GF or AH), HP=Heat Pump, AC=Air Conditioner, OD=Outdoor Unit (AC or HP), ZA=Zone system and TS=Thermostat

Alert Code	Inverter Code	Inverter Flash Code		Priority Condition	Actual Displayed Alert Text	Component or System Operational State and Troubleshooting Tip	How to Clear Alert Code
		Red LED	Green LED				
433	29	2 flashes	9 flashes	Service Soon/ Service Urgent	OD Inverter Compressor Over-current	<p>Compressor phase current is too high.</p> <ul style="list-style-type: none"> • During initial startup, a six minute time delay is implement to prevent the alarm from occurring. • Error occurs when compressor peak phase current is greater than 28 amps. • Inverter will issue inverter code 14 first and slow down to try to reduce the current. • If the current remains high, outdoor unit will stop (compressor and fan) – moderate condition. • Cycle timer is initiated. • If condition occurs five times within 60 consecutive minutes, the system will lockout – critical condition. • This alert code may be triggered by the inverter or the GE Appliances variable capacity outdoor (inverter controlled) unit. • GE Appliances outdoor control may trigger an this alert code if the inverter reduces the compressor speed which is identified as a alert code 441 and the compressor speed (in hz) is below the minimum speed. This will typically occur at start-up. The inverter automatically increases the compressor minimum speed below 45°F in the heating mode and above 115°F ensure the compressor capacity is sufficient for oil return. If alert code 433 occurs and inverter does not indicate an inverter code 29, the GE Appliances outdoor control triggered the alert code 433. • Inverter LEDs will flash code 29. • Refer to the unit service documentation for detailed troubleshooting procedures. <p>Inverter flash code 29.</p> <p>The sequence is:</p> <ul style="list-style-type: none"> • Red LED: Two Flashes • Green LED: Nine Flashes <p>NOTE: <i>Inverter normal operations with no error code present is as follows. Red LED is ON and Green LED is OFF.</i></p>	To clear alert code disconnect power to both the indoor and outdoor units and then reconnect power. Restart system.

Table 27. Outdoor Control 7-Segment Display Alert Codes and Inverter LED Flash Codes

NOTE - System fault and lockout codes take precedence over system status codes (cooling, heating operating percentages or defrost/dehumidification). Only the latest active fault or lockout codes are displayed (if present). If no fault or lockout codes are active, then system status codes are displayed.

GF= Gas Furnace, AH=Air Handler, ID=Indoor unit (GF or AH), HP=Heat Pump, AC=Air Conditioner, OD=Outdoor Unit (AC or HP), ZA=Zone system and TS=Thermostat

Alert Code	Inverter Code	Inverter Flash Code		Priority Condition	Actual Displayed Alert Text	Component or System Operational State and Troubleshooting Tip	How to Clear Alert Code
		Red LED	Green LED				
434	53	5 flashes	3 flashes	Service Soon/ Service Urgent	OD Inverter Comm Error to Main Control	<ul style="list-style-type: none"> Outdoor control has lost communications with the inverter continuously during a single thermostat call and one hour period. Outdoor control will stop all compressor demands – moderate condition. Indoor blower will stop functioning. <p>NOTE: Indoor blower will not run in test mode either when alert code 434 is active. Only after system reset will it operate.</p> <ul style="list-style-type: none"> This alert code will occur if the outdoor unit power is turned off and the indoor unit power (24VAC to GE Appliances outdoor control) remains on, or if the indoor unit power is turned off (24VAC to GE Appliances outdoor control) and the outdoor unit power is on. This could occur while performing service or maintenance procedures on the indoor or outdoor unit. The GE Appliances outdoor control will attempt to re-establish communication to the inverter when the alert code 434 occurs by cycling the outdoor unit contactor off for two minutes. Upon energizing the contactor the GE Appliances outdoor control will attempt to communicate to the inverter for three minutes. This process will be repeated three times in attempt to establish communication before locking out. If the unit is locked out with a critical alert code 434, reset the system by cycling the outdoor unit power off and back on. Then cycle the indoor power off (24VAC to the GE Appliances outdoor control) and then back on. If this condition continuously occurs during a one hour period and during a single thermostat call, the outdoor unit will lock out and display alert code 434 – critical condition. <p>Troubleshooting Options:</p> <ul style="list-style-type: none"> Check for loose or disconnected electrical connections. Interruption of main power to inverter. Inverter LEDs will flash code 53. Refer to the unit service documentation for detailed troubleshooting procedures. <p>Inverter flash code 53.</p> <p>The sequence is:</p> <ul style="list-style-type: none"> Red LED: Five Flashes Green LED: Three Flashes <p>NOTE: Inverter normal operations with no error code present is as follows. Red LED is ON and Green LED is OFF</p>	<p>Automatically clears when the system detects that the issue no longer exists.</p> <p>If the unit is locked out with a critical alert code 434, reset the system by first cycling the outdoor unit power off and back. Then cycle the indoor power off (24VAC to the GE Appliances outdoor control) and then back on.</p>
435	60	6 flashes	OFF	Service Urgent	OD Inverter EEPROM Checksum fault	<p>Inverter internal error.</p> <ul style="list-style-type: none"> When this error occurs, the outdoor control will cycle power to the inverter by opening the contactor for two minutes – moderate condition. Outdoor control will cycle power to the inverter three times and then outdoor unit is locked out – critical condition. Inverter LEDs will flash code 60. Refer to the unit service documentation for detailed troubleshooting procedures. <p>Inverter flash code 60.</p> <p>The sequence is:</p> <ul style="list-style-type: none"> Red LED: Six Flashes Green LED: Off <p>NOTE: Inverter normal operations with no error code present is as follows. Red LED is ON and Green LED is OFF.</p>	<p>To clear alert code disconnect power to outdoor unit and restart.</p>

Table 27. Outdoor Control 7-Segment Display Alert Codes and Inverter LED Flash Codes

NOTE - System fault and lockout codes take precedence over system status codes (cooling, heating operating percentages or defrost/dehumidification). Only the latest active fault or lockout codes are displayed (if present). If no fault or lockout codes are active, then system status codes are displayed.

GF= Gas Furnace, AH=Air Handler, ID=Indoor unit (GF or AH), HP=Heat Pump, AC=Air Conditioner, OD=Outdoor Unit (AC or HP), ZA=Zone system and TS=Thermostat

Alert Code	Inverter Code	Inverter Flash Code		Priority Condition	Actual Displayed Alert Text	Component or System Operational State and Troubleshooting Tip	How to Clear Alert Code
		Red LED	Green LED				
436	62	6 flashes	2 flashes	Service Soon/ Service Urgent	OD Inverter High Heat-Sink Temperature	<p>Inverter heat sink temperature exceeded limit.</p> <ul style="list-style-type: none"> This occurs when the heat sink temperature exceeds the inverter limit. Inverter will issue inverter alert code 13 first and slow down to try to cool the heat sink. If temperature remains high, outdoor unit will stop both compressor and fan – moderate condition. Anti-short cycle is initiated. If condition occurs five times within an hour, system will lockout – critical condition. The screws that hold the inverter to the inverter board were loose causing poor contact between these two components. Tighten screws that hold the heat sink to the inverter control board. <p>NOTE: Wait five minutes for all capacitors to discharge before checking screws.</p> <ul style="list-style-type: none"> Inverter LEDs will flash code 62. Refer to the unit service documentation for detailed troubleshooting procedures. <p>Inverter flash code 62.</p> <p>The sequence is:</p> <ul style="list-style-type: none"> Red LED: Six Flashes Green LED: Two Flashes <p>NOTE: Inverter normal operations with no error code present is as follows. Red LED is ON and Green LED is OFF.</p>	<p>Moderate condition will automatically clear when the inverter sends an alert code clear message.</p> <p>Critical condition is cleared by disconnecting power to the outdoor unit and restart.</p>
437	65	6 flashes	5 flashes	Service Soon/ Service Urgent	OD Inverter Heat-Sink temp Sensor Fault	<p>Heat sink temperature sensor fault has occurred (temperature less than 4°F or greater than 264°F after 10 minutes of operation).</p> <ul style="list-style-type: none"> When the temperature sensor detects a temperature less than 4°F or greater than 264°F after 10 minutes of operation. Outdoor unit will stop both compressor and fan – moderate condition. Anti-short cycle is initiated. If condition occurs five times within an hour, system will lockout – critical condition. Inverter LEDs will flash code 65. Refer to the unit service documentation for detailed troubleshooting procedures. <p>Inverter flash code 65.</p> <p>The sequence is:</p> <ul style="list-style-type: none"> Red LED: Six Flashes Green LED: Five Flashes <p>NOTE: Inverter normal operations with no error code present is as follows. Red LED is ON and Green LED is OFF.</p>	<p>Moderate priority condition will automatically clear when the inverter sends an alert code clear message.</p> <p>Critical priority condition can be cleared by disconnecting and reconnecting power to outdoor unit to restart.</p>

Table 27. Outdoor Control 7-Segment Display Alert Codes and Inverter LED Flash Codes

NOTE - System fault and lockout codes take precedence over system status codes (cooling, heating operating percentages or defrost/dehumidification). Only the latest active fault or lockout codes are displayed (if present). If no fault or lockout codes are active, then system status codes are displayed.

GF= Gas Furnace, AH=Air Handler, ID=Indoor unit (GF or AH), HP=Heat Pump, AC=Air Conditioner, OD=Outdoor Unit (AC or HP), ZA=Zone system and TS=Thermostat

Alert Code	Inverter Code	Inverter Flash Code		Priority Condition	Actual Displayed Alert Text	Component or System Operational State and Troubleshooting Tip	How to Clear Alert Code
		Red LED	Green LED				
438	73	7 flashes	3 flashes	Service Urgent	OD Inverter PFC Input Over-current	<p>The inverter has detected a power factor correction (PFC) circuit over-current condition.</p> <ul style="list-style-type: none"> The inverter has detected an PFC over current condition. This may be caused by a high load condition, high pressure, or outdoor fan failure. Outdoor control will display the code when the inverter has detected the error – moderate condition. After three minutes, the inverter will reset and the compressor will resume operation. If the error condition occurs 10 times within a 60 minute rolling time period, the outdoor unit control will lock out operation of the outdoor unit – critical condition. Possible issue is system running at high pressures. Check for high pressure trips or other alert codes in thermostat and outdoor control. Inverter LEDs will flash code 73. Refer to the unit service documentation for detailed troubleshooting procedures. <p>Inverter flash code 73.</p> <p>The sequence is:</p> <ul style="list-style-type: none"> Red LED: Seven Flashes Green LED: Three Flashes <p>NOTE: Inverter normal operations with no error code present is as follows. Red LED is ON and Green LED is OFF.</p>	<p>Moderate priority condition is automatically cleared when the inverter sends a clear message.</p> <p>Critical priority condition will automatically clear when inverter is power cycled.</p>

Table 27. Outdoor Control 7-Segment Display Alert Codes and Inverter LED Flash Codes

NOTE - System fault and lockout codes take precedence over system status codes (cooling, heating operating percentages or defrost/dehumidification). Only the latest active fault or lockout codes are displayed (if present). If no fault or lockout codes are active, then system status codes are displayed.

GF= Gas Furnace, AH=Air Handler, ID=Indoor unit (GF or AH), HP=Heat Pump, AC=Air Conditioner, OD=Outdoor Unit (AC or HP), ZA=Zone system and TS=Thermostat

Alert Code	Inverter Code	Inverter Flash Code		Priority Condition	Actual Displayed Alert Text	Component or System Operational State and Troubleshooting Tip	How to Clear Alert Code
		Red LED	Green LED				
440	13	1 flash	3 flashes	Information Only-Dealer	<p>OD Inverter Compressor Slowdown - High Heat-Sink temperature</p>	<p>Compressor slowdown due to high heat sink temperature.</p> <ul style="list-style-type: none"> Heat sink temperature is approaching limit. The compressor speed automatically slows to reduce heat sink temperature. The control sets indoor CFM and outdoor RPM to values according to demand percentage rather than the actual Hz. The screws that hold the inverter to the inverter board may be loose causing poor contact between these two components. Tighten screws that hold the heat sink to the inverter control board. <p>NOTE: Wait five minutes for all capacitors to discharge before checking screws.</p> <ul style="list-style-type: none"> This error code is primarily for informational purposes as the inverter controls the compressor speed to operate within design parameters. Typically the inverter will make a minor speed reduction of 4 Hz (approximately a 5-6% speed reduction) for a brief period of time and to reduce the heat sink temperature and will then resume normal operation. This may occur at high outdoor temperatures (above 110°F) for brief periods of time (3 – 4 minutes) and is normal and expected operation of the inverter controlling the compressor safely within design parameters. The inverter finned aluminum heat sink is located on the back side of the inverter in the condenser air stream. If the alert code 440 occur frequently, especially at lower outdoor temperatures, check the heat sink for debris that may reduce heat transfer or possible obstructions that may impact air flow across the heat sink. The inverter will begin to briefly reduce the compressor speed when the heat sink temperature rises above 185°F and will allow the inverter to resume the requested compressor demand speed once the inverter heat sink reaches 176°F. The heat sink temperature, compressor speed in Hertz & the Inverter Compressor Speed Reduction status ("On" or "Off ") notification can be viewed under the outdoor unit Diagnostics section of the thermostat dealer control center. Inverter LEDs will flash code 13. Refer to the unit service documentation for detailed troubleshooting procedures. <p>Inverter flash code 13.</p> <p>The sequence is:</p> <ul style="list-style-type: none"> Red LED: One Flash Green LED: Three Flashes <p>NOTE: Inverter normal operations with no error code present is as follows. Red LED is ON and green LED is OFF.</p>	Automatically clears when the condition no longer exists.

Table 27. Outdoor Control 7-Segment Display Alert Codes and Inverter LED Flash Codes

NOTE - System fault and lockout codes take precedence over system status codes (cooling, heating operating percentages or defrost/dehumidification). Only the latest active fault or lockout codes are displayed (if present). If no fault or lockout codes are active, then system status codes are displayed.

GF= Gas Furnace, AH=Air Handler, ID=Indoor unit (GF or AH), HP=Heat Pump, AC=Air Conditioner, OD=Outdoor Unit (AC or HP), ZA=Zone system and TS=Thermostat

Alert Code	Inverter Code	Inverter Flash Code		Priority Condition	Actual Displayed Alert Text	Component or System Operational State and Troubleshooting Tip	How to Clear Alert Code
		Red LED	Green LED				
441	14	1 flash	4 flashes	Information Only-Dealer	<p>OD Inverter Compressor Slowdown - High Compressor Current</p>	<p>This alert code is for more information than an issue with the system.</p> <ul style="list-style-type: none"> When the inverter gets close to the current or heat sink temperature limit, it will limit the ramp rate. Instead of changing compressor speed at 1 hz/second, it changes to 5 hz/20 seconds. Compressor slowdown due to high compressor current. Compressor current is approaching limit. The compressor speed automatically slows. This error code is primarily for informational purposes as the inverter controls the compressor to operate within design parameters. Alert code 441 typically occurs at startup as the compressor current increases rapidly during startup. The inverter will reduce the compressor speed by 4 Hz and slow the compressor ramp up speed to the requested compressor demand speed (capacity). This is normal and expected operation of the inverter to control the inverter within design parameters. In most cases the alert code 441 notification does not require any additional service or diagnostic procedures. The control sets indoor CFM and outdoor RPM to values according to demand percentage rather than the actual Hz. Possible issue is system running at high pressures. Check for high pressure trips or other alert codes in thermostat and outdoor control. Inverter LEDs will flash code 14. Refer to the unit service documentation for detailed troubleshooting procedures. <p>Inverter flash code 14.</p> <p>The sequence is:</p> <ul style="list-style-type: none"> Red LED: One Flash Green LED: Four Flashes <p>NOTE: Inverter normal operations with no error code present is as follows. Red LED is ON and green LED is OFF.</p>	Automatically clears when the condition no longer exists.

Table 27. Outdoor Control 7-Segment Display Alert Codes and Inverter LED Flash Codes

System Refrigerant

IMPORTANT

The system must be operating at full capacity during charging. Using the Charge Mode Jumper on the outdoor control ensures the unit is running at 100% capacity. Confirm outdoor unit running capacity.

This section outlines the procedures to:

- Connect a gauge set for testing and charging as illustrated in Figure 48.
- Check and adjust indoor airflow as described in Figure 49.
- Add or remove refrigerant using the weigh-in method shown in Figure 50.
- Verify the charge using the subcooling method described in Figure 51.

IMPORTANT

Unit must be operating at 100% capacity to be charged properly.

Adding or Removing Refrigerant

This system uses HFC-410A refrigerant which operates at much higher pressures than HCFC-22.

Indoor Airflow Check

Check airflow using the Delta-T (DT) process using the illustration in Figure 49.

Charge Mode Jumper

To initiate the NS23AM Charge Mode function, install the jumper across the two Charge Mode Pins (CHRG MODE) on the outdoor control. The Charge Mode can be used when charging the system with refrigerant, checking the refrigerant charge, pumping down the system and performing other service procedures that requires outdoor unit operation at 100% capacity.

NS23AM Charge Mode Operation with a Conventional 24VAC Thermostat

On applications with a conventional 24VAC thermostat, the charge mode jumper must be installed on the Charge Mode Pins after providing a Y1 cooling demand to the NS23AM to initiate the Charge Mode. A cooling blower demand must also be provided to initiate blower operation on the cooling speed on the indoor unit. The compressor and outdoor fan motor will operate at 100% capacity. To exit the charging mode, remove the Charge Mode Jumper and remove the Y1 Cooling demand and indoor blower demand. The Charge Mode has a maximum time of 60 minutes and will automatically exit the charge mode after 60 minutes is the charge mode jumper is left in place.

GAUGE SET

CONNECTIONS FOR TESTING AND CHARGING

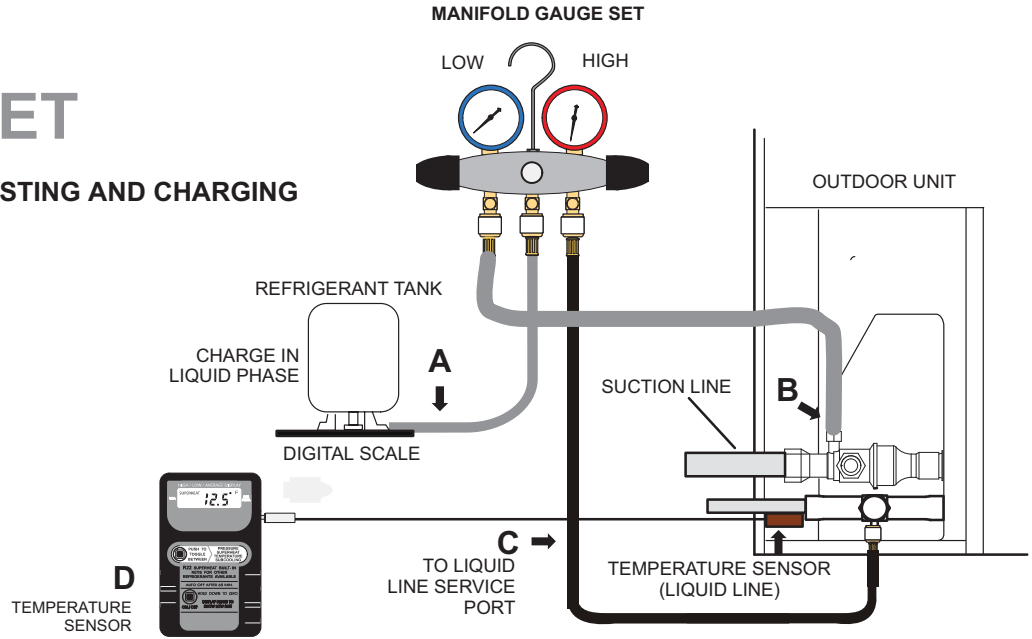

- A. CLOSE MANIFOLD GAUGE SET VALVES AND CONNECT THE CENTER HOSE TO A CYLINDER OF HFC-410A SET FOR LIQUID PHASE CHARGING.
- B. CONNECT THE MANIFOLD GAUGE SET'S LOW PRESSURE SIDE TO THE SUCTION LINE SERVICE PORT.
- C. CONNECT THE MANIFOLD GAUGE SET'S HIGH PRESSURE SIDE TO THE LIQUID LINE SERVICE PORT.
- D. POSITION TEMPERATURE SENSOR ON LIQUID LINE NEAR LIQUID LINE SERVICE PORT.

Figure 48. Gauge Set Connections

AIRFLOW

INDOOR COIL

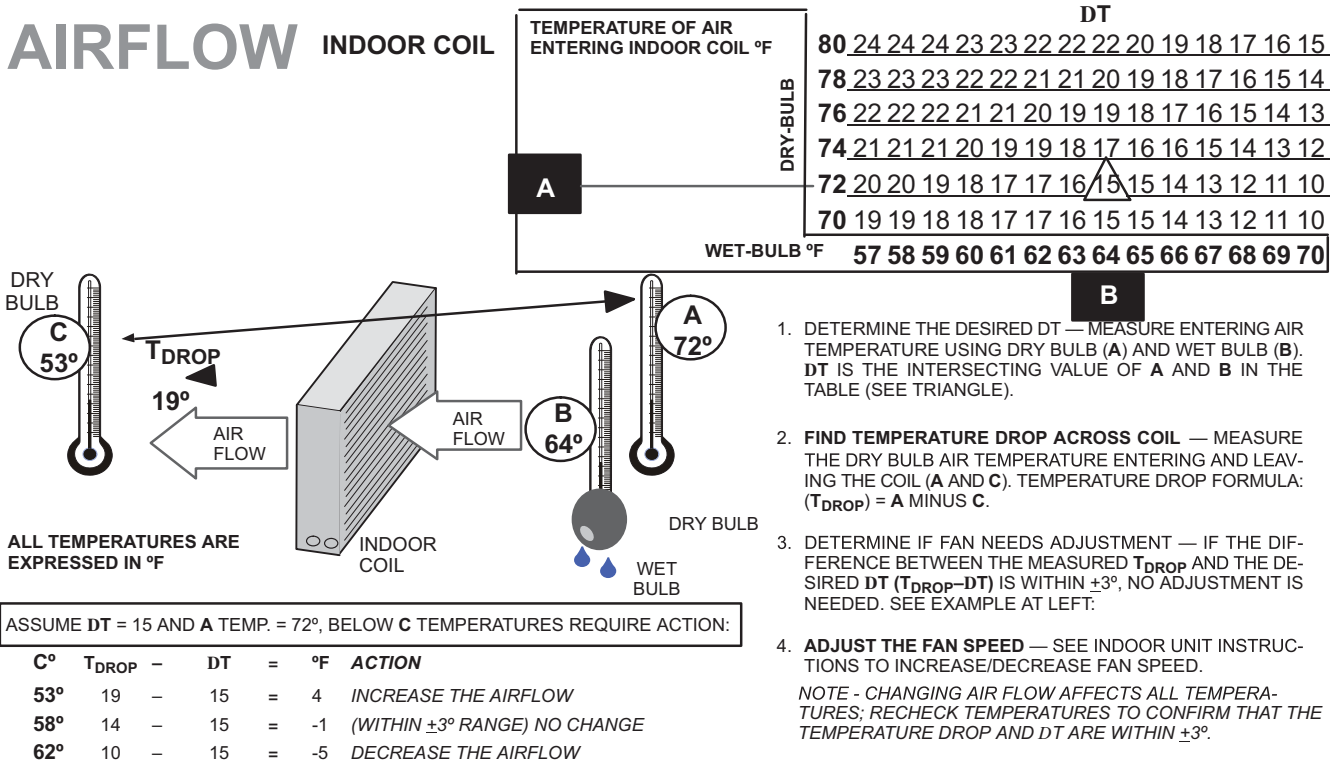



Figure 49. Checking Indoor Airflow over Evaporator Coil using Delta-T Chart

Use the WEIGH-IN method for adding initial refrigerant charge, and then use SUBCOOLING method for for verifying refrigerant charge.

WEIGH-IN CHARGING METHOD

64°F (17.7°C) and Below

Amount specified on nameplate \pm Adjust amount for variation in line set length and liquid line diameter using table below. = Total charge



Liquid Line Set Diameter	HFC-410A (ounces per foot)
5/16"	0.40
3/8"	0.60
1/2"	1.00

NOTE - Insulate liquid line when it is routed through areas where the surrounding ambient temperature could become higher than the temperature of the liquid line or when pressure drop is equal to or greater than 20 psig.

NOTE - The nameplate is shown for illustration purposes only. Go to actual nameplate on outdoor unit for charge information.

Charging Formula for Liquid Line Charge Adjustments

[(Line set oz./ft. x total length) - (factory charge for line set)] = charge adjustment

Example: Units are factory-charged for 15 feet (4.6 meters) of 3/8" line set. Factory charge for 3/8" is 0.60 oz/ft x 15 = 9.0 ounces.

Figure 50. Using HFC-410A Weigh-In Method

SUBCOOLING CHARGING METHOD

*(All charging **MUST** be performed while system is operating either at maximum speed or 100% demand.)*

- THE DIAGNOSTIC SCREEN ON THE THERMOSTAT OR OUTDOOR CONTROL 7-SEGMENT DISPLAY WILL SHOW INDOOR AND OUTDOOR MOTOR CFMS OR RPMS.
- MEASURE OUTDOOR AMBIENT TEMPERATURE.
- CONNECT GAUGE SET.
- CHECK LIQUID AND VAPOR LINE PRESSURES. COMPARE PRESSURES WITH COOLING MODE NORMAL OPERATING PRESSURES IN THE APPLICABLE CHARGING STICKER, NORMAL OPERATING PRESSURES AT MAXIMUM CAPACITY.

NOTE - THE REFERENCE TABLE IS A GENERAL GUIDE. EXPECT MINOR PRESSURE VARIATIONS. SIGNIFICANT DIFFERENCES MAY MEAN IMPROPER CHARGE OR OTHER SYSTEM PROBLEM.

5. SET THERMOSTAT FOR HEAT/COOL DEMAND, DEPENDING ON MODE BEING USED:

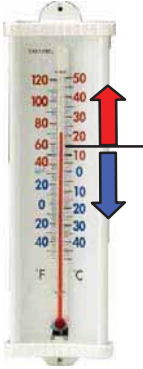

USE COOLING MODE \uparrow 60°F (15°C)

USE HEATING MODE \downarrow

USING COOLING MODE — WHEN THE OUTDOOR AMBIENT TEMPERATURE IS 60°F (15°C) AND ABOVE. TARGET SUBCOOLING VALUES (MAXIMUM / 100% CAPACITY) IN APPLICABLE CHARGING STICKER ARE BASED ON 70 TO 80°F (21-27°C) INDOOR RETURN AIR TEMPERATURE; IF NECESSARY, OPERATE HEATING TO REACH THAT TEMPERATURE RANGE; THEN SET THE INITIAL COOLING DEMAND AT MAXIMUM CAPACITY. THE PREFERRED METHOD IS TO USE THE "CHARGE MODE" JUMPER ON THE OUTDOOR CONTROL. SEE CHARGE MODE JUMPER SECTION ON PAGE 80. WHEN PRESSURES HAVE STABILIZED, CONTINUE WITH STEP 6.

- READ THE LIQUID LINE TEMPERATURE; RECORD IN THE LIQ° SPACE.
- READ THE LIQUID LINE PRESSURE; THEN FIND ITS CORRESPONDING TEMPERATURE IN THE TEMPERATURE/ PRESSURE CHART LISTED IN THE APPLICABLE CHARGING STICKER AND RECORD IT IN THE SAT° SPACE.
- SUBTRACT LIQ° TEMPERATURE FROM SAT° TEMPERATURE TO DETERMINE SUBCOOLING; RECORD IT IN SC° SPACE.
- COMPARE SC° RESULTS WITH APPLICABLE CHARGING STICKER, BEING SURE TO NOTE ANY ADDITIONAL CHARGE FOR LINE SET AND/OR MATCH-UP.
- IF SUBCOOLING VALUE IS GREATER THAN SHOWN IN APPLICABLE CHARGING STICKER FOR THE APPLICABLE UNIT, REMOVE REFRIGERANT; IF LESS THAN SHOWN, ADD REFRIGERANT.
- IF REFRIGERANT IS ADDED OR REMOVED, REPEAT STEPS 6 THROUGH 10 TO VERIFY CHARGE.
- DISCONNECT GAUGE SET AND RE-INSTALL BOTH THE LIQUID AND SUCTION SERVICE VALVE CAPS.

SAT° = _____

LIQ° = _____

SC° = _____

Figure 51. Using HFC-410A Subcooling Method - High Speed (High Capacity)

°F	Psig	°F	Psig	°F	Psig	°F	Psig	°F	Psig	°F	Psig	°F	Psig	°F	Psig
32	100.8	48	137.1	63	178.5	79	231.6	94	290.8	110	365.0	125	445.9	141	545.6
33	102.9	49	139.6	64	181.6	80	235.3	95	295.1	111	370.0	126	451.8	142	552.3
34	105.0	50	142.2	65	184.3	81	239.0	96	299.4	112	375.1	127	457.6	143	559.1
35	107.1	51	144.8	66	187.7	82	242.7	97	303.8	113	380.2	128	463.5	144	565.9
36	109.2	52	147.4	67	190.9	83	246.5	98	308.2	114	385.4	129	469.5	145	572.8
37	111.4	53	150.1	68	194.1	84	250.3	99	312.7	115	390.7	130	475.6	146	579.8
38	113.6	54	152.8	69	197.3	85	254.1	100	317.2	116	396.0	131	481.6	147	586.8
39	115.8	55	155.5	70	200.6	86	258.0	101	321.8	117	401.3	132	487.8	148	593.8
40	118.0	56	158.2	71	203.9	87	262.0	102	326.4	118	406.7	133	494.0	149	601.0
41	120.3	57	161.0	72	207.2	88	266.0	103	331.0	119	412.2	134	500.2	150	608.1
42	122.6	58	163.9	73	210.6	89	270.0	104	335.7	120	417.7	135	506.5	151	615.4
43	125.0	59	166.7	74	214.0	90	274.1	105	340.5	121	423.2	136	512.9	152	622.7
44	127.3	60	169.6	75	217.4	91	278.2	106	345.3	122	428.8	137	519.3	153	630.1
45	129.7	61	172.6	76	220.9	92	282.3	107	350.1	123	434.5	138	525.8	154	637.5
46	132.2	62	175.4	77	224.4	93	286.5	108	355.0	124	440.2	139	532.4	155	645.0
47	134.6			78	228.0			109	360.0			140	539.0		

Table 28. HFC-410A Temperature (°F) - Pressure (Psig)

Charging Temperatures and Pressures – High Speed Only				
Unit Capacity	-024	-036	-048	-060
Table 1 – Subcooling Values (High Capacity)				
<i>Saturation Temperature minus Liquid Temperature °F (°C) ± 1°F (0.5°C)</i>				
Temp. °F (°C)	12 (6.7)	6 (3.3)	10 (5.6)	10 (5.6)
Table 2 – Approach Values (High Capacity)				
<i>Liquid Line Temperature minus Outdoor Ambient Temperature °F (°C) ± 1°F (0.5°C)</i>				
Temp. °F (°C)	3 (1.7)	7 (3.9)	3 (1.7)	3 (1.7)
Table 3 – Normal Operating Pressures (Liquid ± 10 / Suction ± 5 psig)				
Air Temp Entering Outdoor Coil °F (°C)	<i>The values below are typical pressures; indoor evaporator match-up, indoor air quantity, and evaporator load will cause the pressure to vary.</i>			
	Liquid Line Pressure / Vapor Line Pressure			
65 (18.3)	234 / 141	228 / 133	228 / 137	229 / 132
70 (21.1)	251 / 142	243 / 134	244 / 138	246 / 134
75 (23.9)	271 / 143	262 / 136	264 / 139	266 / 135
80 (26.6)	292 / 144	283 / 137	284 / 140	288 / 136
85 (29.4)	314 / 145	305 / 138	306 / 141	310 / 137
90 (32.2)	337 / 146	328 / 139	329 / 142	333 / 138
95 (35.0)	361 / 147	352 / 141	353 / 144	358 / 139
100 (37.7)	387 / 148	377 / 142	378 / 145	383 / 140
105 (40.6)	414 / 149	403 / 143	403 / 146	410 / 141
110 (43.3)	444 / 150	431 / 144	430 / 147	439 / 142
115 (46.1)	474 / 151	459 / 145	459 / 148	468 / 144



Figure 52. Charging Label