

PGS968SEP

GE Profile™ Series 30" Slide-In Gas Range

Dimensions and Installation Information (in inches)

Rear filler strip or backguard are available for these ranges

Note: Door handle protrudes 3" from door face. Cabinets and drawers on adjacent 45° and 90° walls should be placed to avoid interference with the handle.

Note: Cabinets installed adjacent to slide-in ranges must have an adhesion spec of at least 194° temperature rating.

Optional Kits for Slide-In Gas Ranges:
(Available at additional cost)

Lower/Side Trim Kits

JXS56BB - Lower Trim Kit (Black)

Accessory Backguards

JXS32SS - Brushed-Chrome Accessory Backguard

Rear Filler Strip

WB07T10680 - Black Filler Strip Assembly

Installation Information: Before installing, consult installation instructions packed with product for current dimensional data.

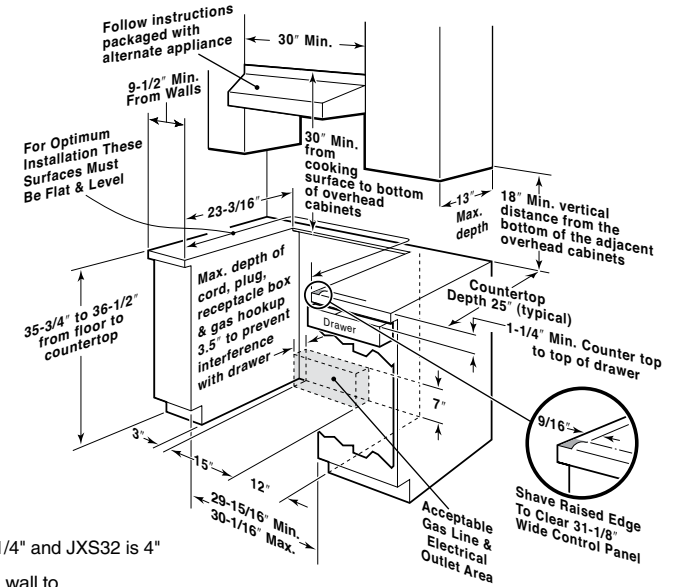
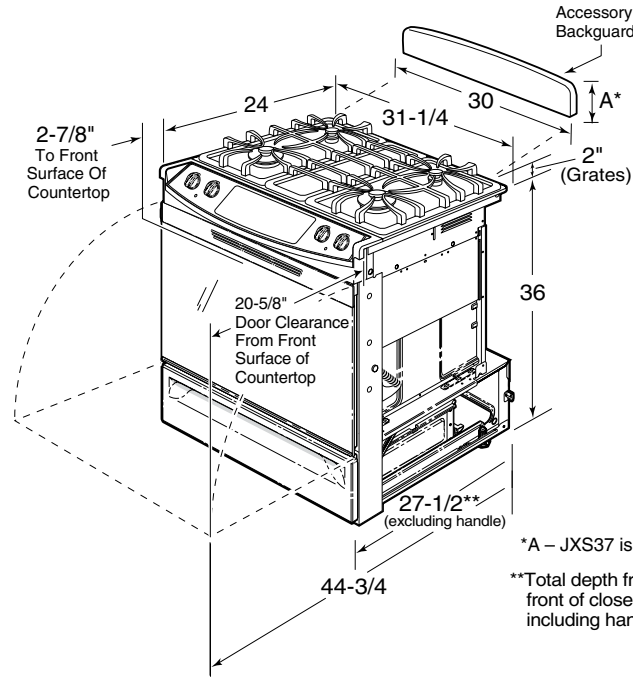

Counter Cutout Dimensions (in inches)

If you are NOT using the Filler strip or Backguard:

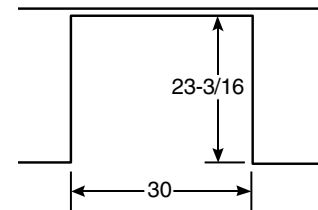

If you are using the Filler strip or Backguard:

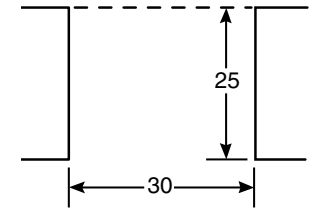

For answers to your Monogram® or GE® appliance questions, visit our website at geappliances.com or call GE Answer Center® service, 800.626.2000.



All GE ranges are equipped with an Anti-Tip device. The installation of this device is an important, required step in the installation of the range.



PGS968SEP

GE Profile™ Series 30" Slide-In Gas Range

Features and Benefits

- Gas On Glass Cooktop - Ceramic glass surface looks sleek and is incredibly easy to wipe clean
- Two-speed Convection Oven - Circulated convection heat can be delivered at a high speed for heavy foods or a low speed for more delicate foods to enhance the baking or roasting results
- Convection Bake - This setting is optimal for baking casseroles or lasagnas, yeast breads, pies and pizzas with no need to turn the pan
- Convection Roast - Optimal for larger cuts of meat, this setting rotates the heat around all sides, sealing in the juices, producing rotisserie results at up to 25% faster than a conventional oven
- 4.1 cu. ft. Oven Capacity - Enough room to cook an entire meal at once
- Self-clean Oven - Self-clean allows you to spare yourself from the trouble and effort it takes to scrub the oven interior. The oven does all the work!
- Self-clean Heavy-duty Oven Racks - Tough, double-coated racks can stay in the oven during the self-clean cycle to eliminate hand cleaning
- Glass Touch Controls - Smooth controls are easy to use and add a sophisticated style to the kitchen
- Power Boil Burner - Delivers 15,000 BTUs of forceful heat for rapid boiling
- Precise Simmer Burner - Simmer burners allows for low, even heat distribution that is ideal delicate foods and sauces
- Model PGS968SEPSS - Stainless steel



imagination at work