

PGS975SEP

GE Profile™ Series 30" Slide-In Gas Range

Dimensions and Installation Information (in inches)

Rear filler strip or backguard are available for these ranges

Note: Door handle protrudes 3" from door face. Cabinets and drawers on adjacent 45° and 90° walls should be placed to avoid interference with the handle.

Note: Cabinets installed adjacent to slide-in ranges must have an adhesion spec of at least 194° temperature rating.

Optional Kits for Slide-In Gas Ranges:

(Available at additional cost)

Lower/Side Trim Kits

JXS56BB - Lower Trim Kit (Black)

Accessory Backguards

JXS32SS - Brushed-Chrome Accessory Backguard

Rear Filler Strip

WB07T10680 - Black Filler Strip Assembly

Installation Information: Before installing, consult installation instructions packed with product for current dimensional data.

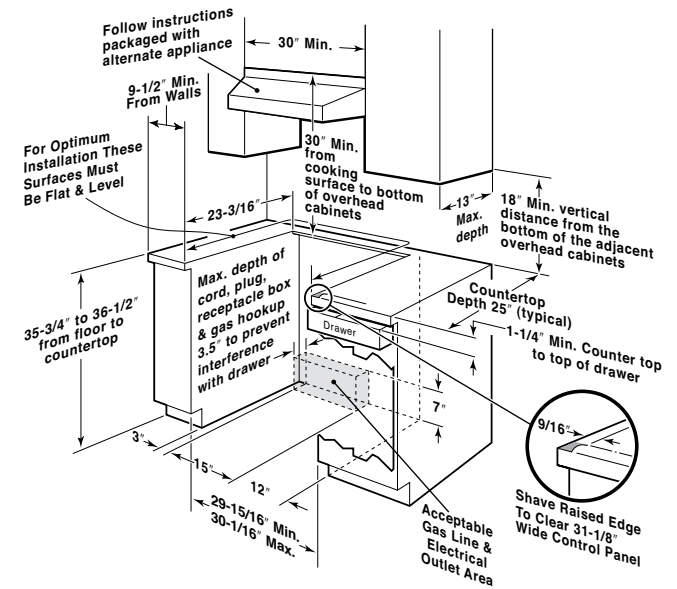
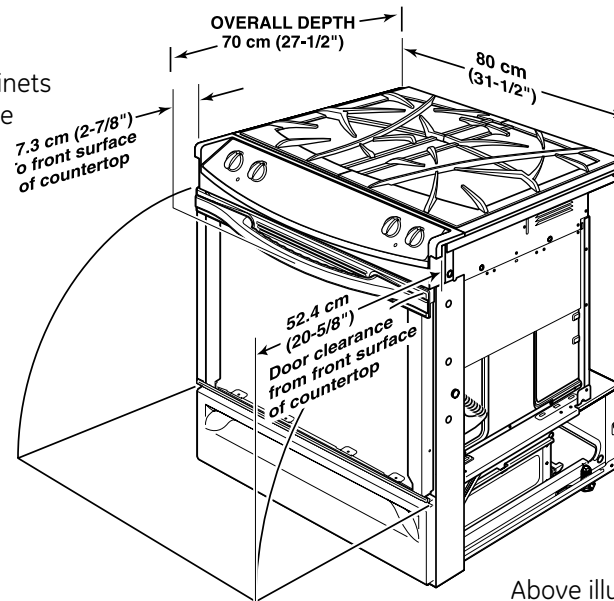

Above illustration intended for dimensional reference only. Refer to photograph for actual product appearance.

Counter Cutout Dimensions (in inches)

If you are NOT using the Filler strip or Backguard:

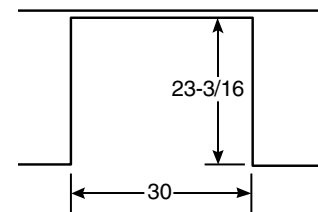

If you are using the Filler strip or Backguard:

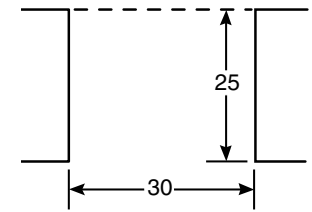

For answers to your Monogram® or GE® appliance questions, visit our website at geappliances.com or call GE Answer Center® service, 800.626.2000.



All GE ranges are equipped with an Anti-Tip device. The installation of this device is an important, required step in the installation of the range.



PGS975SEP

GE Profile™ Series 30" Slide-In Gas Range

Features and Benefits

- Deep recessed cooktop - Deep recessed cooktop keeps spills, and everything else, contained in one area that's easy to wipe clean
- Two speed convection oven - Circulated convection heat can be delivered at a high speed for heavy foods or a low speed for more delicate foods to enhance the baking or roasting results
- Convection Bake - This setting is optimal for baking casseroles or lasagnas, yeast breads, pies and pizzas with no need to turn the pan
- Convection roast - Optimal for larger cuts of meat, this setting rotates the heat around all sides, sealing in the juices, producing rotisserie results at up to 25% faster than a conventional oven
- 4.1 cu. ft. oven capacity - Enough room to cook an entire meal at once
- 18,000 BTU Stacked Burner - Features a unique two-in-one burner design for 18,000 BTU boiling or gentle 140 degrees simmer
- Glass touch controls - Smooth controls are easy to use and add a sophisticated style to the kitchen
- Self-clean oven - Self-clean allows you to spare yourself from the trouble and effort it takes to scrub the oven interior. The oven does all the work!
- Precise simmer burner - Simmer burners allows for low, even heat distribution that is ideal delicate foods and sauces
- Self-clean heavy-duty oven racks - Tough, double-coated racks can stay in the oven during the self-clean cycle to eliminate hand cleaning
- Model PGS975SEPSS - Stainless steel



imagination at work