

Conversion Instructions

Converting to LP (Propane) Gas or Converting Back to Natural Gas from LP

20" and 24" Standard Twin Burner Gas Range with Electric Ignition



BEFORE YOU BEGIN

Read these instructions completely and carefully.

IMPORTANT - Save these instructions for local inspector's use.

IMPORTANT - OBSERVE ALL GOVERNING CODES AND ORDINANCES.

Note to Installer - Be sure to leave these instructions, orifices and screws with the Consumer.

Note to consumer - Keep these instructions with your Owner's Manual for future reference.

THIS RANGE IS FACTORY SET FOR USE WITH NATURAL GAS. USE THESE INSTRUCTIONS WHEN CONVERTING TO LP (PROPANE) GAS AND WHEN CONVERTING BACK TO NATURAL GAS.



WARNING

This conversion kit must be installed by a qualified service agency in accordance with the manufacturer's instructions and all applicable codes and requirements of the authority having jurisdiction. If the information in these instructions is not followed exactly, a fire, explosion or production of carbon monoxide may result, causing property damage, personal injury or loss of life. The qualified service agency is responsible for the proper installation of this kit. The installation is not proper and complete until the operation of the converted appliance is checked as specified in the manufacturer's instructions supplied with the kit.

BURNER SPECIFICATIONS

BURNER OUTPUT RATINGS: BTU/HR		
Burner	BTU Rate	Orifice Size
Surface	9,100	#54 (0.057")
Oven	13,000	#51 (0.068")

LP (PROPANE) GAS, 10" WCP		
Burner	BTU Rate	Orifice Size
Surface	8,000	#66 (0.033")
Oven	13,000	#58 (0.042")

HIGH ALTITUDE OUTPUT RATINGS: BTU/HR			
NATURAL GAS-4" W.C.P.			
	High Altitude Rate	Orifice Size	Prod. Service Number
@ 3,000 FT	8050	0.054"	WB28K10304
@ 6,000 FT	7100	0.050"	WB28K10305

HIGH ALTITUDE OUTPUT RATINGS: BTU/HR			
LP-10" W.C.P.			
	High Altitude Rate	Orifice Size	Prod. Service Number
@ 3,000 FT	7050	0.031"	WB28K0046
@ 6,000 FT	6250	0.029"	WB28K10306

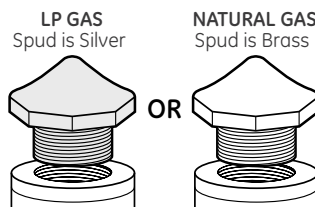

TOOLS REQUIRED

Adjustable wrench
1/2" open-end wrench
Pliers
Phillips head screwdriver

Flat-blade screwdriver (blade width approximately 3/32" across)
Nut driver (5/16" or small adjustable wrench)



imagination at work

STEP 1 PREPARE RANGE FOR CONVERSION

- Disconnect main gas supply to the range.
- Disconnect the electrical power to the range.
 - If range has not been connected to the gas supply, or if a flexible connection was made, the range may be pulled out from the wall to make conversion easier.



CAUTION

If the gas supply to the range is disconnected for any reason, see the installation instructions for proper connection and safety precautions.

STEP 2 CONVERT THE PRESSURE REGULATOR



WARNING

Do not remove the pressure regulator from the range.

- Locate the pressure regulator on the back of the range on the left side.
- Use an adjustable wrench to remove the hex-nut from the pressure regulator.

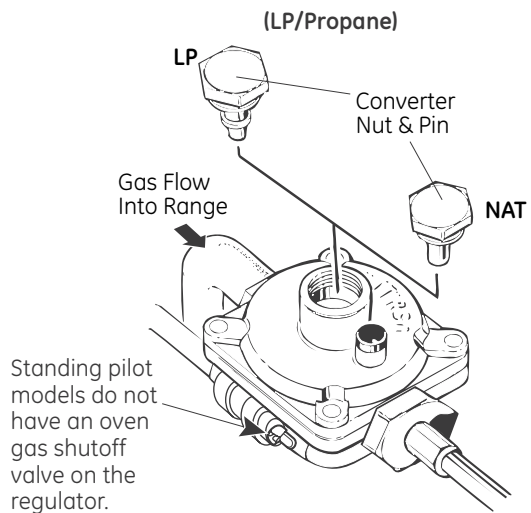

- Apply sideward finger pressure to remove the plastic pin from the nut.

Note: To remove the pin, place the nut on a flat surface and press the pin sideways with your fingers.

- Rotate the pin 180 degrees and snap the pin back into the nut.

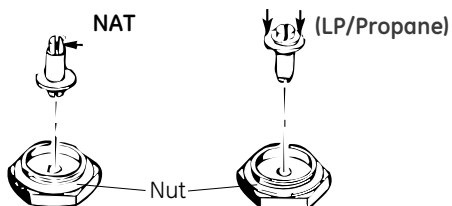

- Reinsert the assembly into the regulator and tighten the hex-nut. Do not overtighten.

STEP 3 CONVERTING THE SURFACE BURNERS

- Lift the burner assemblies straight up (set aside) to gain access to the surface burner orifice spuds.
- Using a 5/16" nutdriver, or adjustable wrench, remove each of the four (4) spuds on the surface burner gas inlet tubes. Replace them with the correct gas spuds mounted in a holder at the right rear of the range, above the regulator. Natural gas spuds are "BRASS" and LP gas spuds are "SILVER". Return the spuds you removed from the inlet tubes to the holder above the regulator. To prevent leakage, make sure the spuds are securely screwed into the gas inlet tubes.
- Replace the burner assemblies.

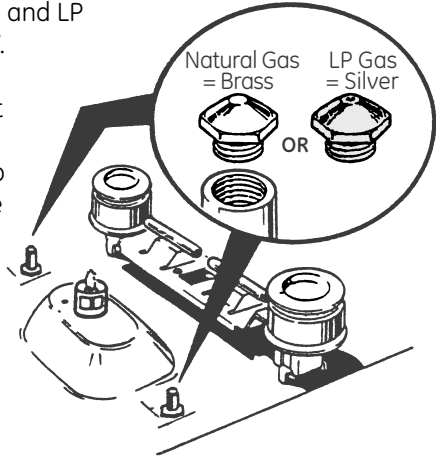

STEP 4 CONVERT THE OVEN BURNER ORIFICE

Oven Burner

- Remove oven door, broiler pan and rack, oven racks, and oven bottom. The lower burner orifice hood is located behind the broiler drawer (on some models, a metal shield must be removed to access the orifice hood).
- To convert to LP gas, use a 1/2" wrench to turn the lower burner orifice hood clockwise. Tighten the hood until it is snug. To prevent damage, do not overtighten the hood.

This assembly is located at the rear of the broiler compartment.

A metal shield may need to be removed on some models to access the orifice hood.

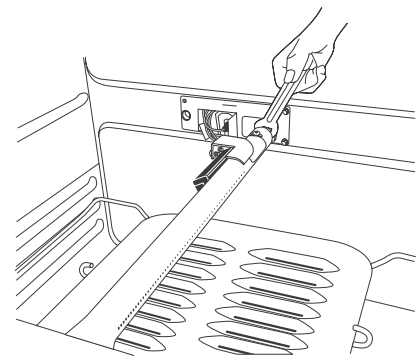

STEP 5 ADJUSTING THE AIR SHUTTER

To adjust the air shutter for LP gas, loosen the Phillips head screw and rotate the shutter to the full open position. **For natural gas**, the shutter should be open 1/2" or about three-quarters of the way open.

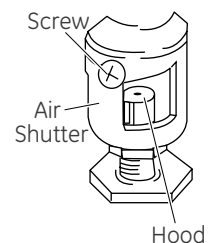

STEP 6 CHECK FOR LEAKS

- Connect range to gas.
When all connections have been made, make sure all range controls are in the off position and turn on the main gas supply valve. Use a liquid leak detector at all joints and connections to check for leaks in the system.



CAUTION: DO NOT USE A FLAME TO CHECK FOR GAS LEAKS.

When using test pressures greater than 1/2 psig to pressure test the gas supply system of the residence, disconnect the range and individual shutoff valve from the gas supply piping. When using test pressures of 1/2 psig or less to test the gas supply system, simply isolate the range from the gas supply system by closing the individual shutoff valve.

STEP 7 CHECKING THE FLAME SIZE

Turn on oven burner.
Check the flame size for LP gas. The flame should have approximately 1-inch blue cones. After 30 seconds of burner operation, check for flames lifting off the burner ports. If lifting is observed, gradually reduce the air shutter opening until flames are stabilized.

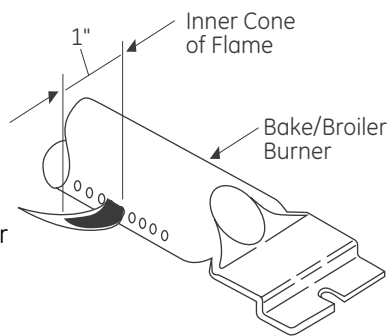

Some yellow tipping may be normal on LP gas. See **Step 8**.

STEP 8 CHECK QUALITY OF FLAMES

The combustion quality of the burner flames needs to be determined visually.



(A) Yellow flames–
Further adjustment required



(B) Yellow tips–
Normal for LP Gas



(C) Soft Blue flames–
Normal for Natural Gas

If burner flames look like (A), further air shutter adjustment is required. Normal burner flames should look like (B) or (C), depending on the type of gas you use. With LP gas, some yellow tipping on the outer cones is normal.

STEP 9 REPLACE OVEN PARTS

Replace oven bottom, oven racks, oven door and broiler pan and rack.

STEP 10 COMPLETE AND ADHERE CONVERSION STICKER

Upon completion of this conversion, fill out the LP sticker included with the instructions. Once complete, apply the sticker to the back of the range near the regulator. The conversion sticker **must** reflect the change in fuel.

If converting back to natural gas from LP, remove the LP sticker from the back of the range.

Save these instructions for reference in case the range must be converted back to natural gas.

The conversion to LP gas for the standard twin burner gas range with electric ignition is now completed.