

USER GUIDE

SAFETY • INSTALLATION & INTEGRATION • OPERATING INSTRUCTIONS • MAINTENANCE • **SERVICE**

Parts

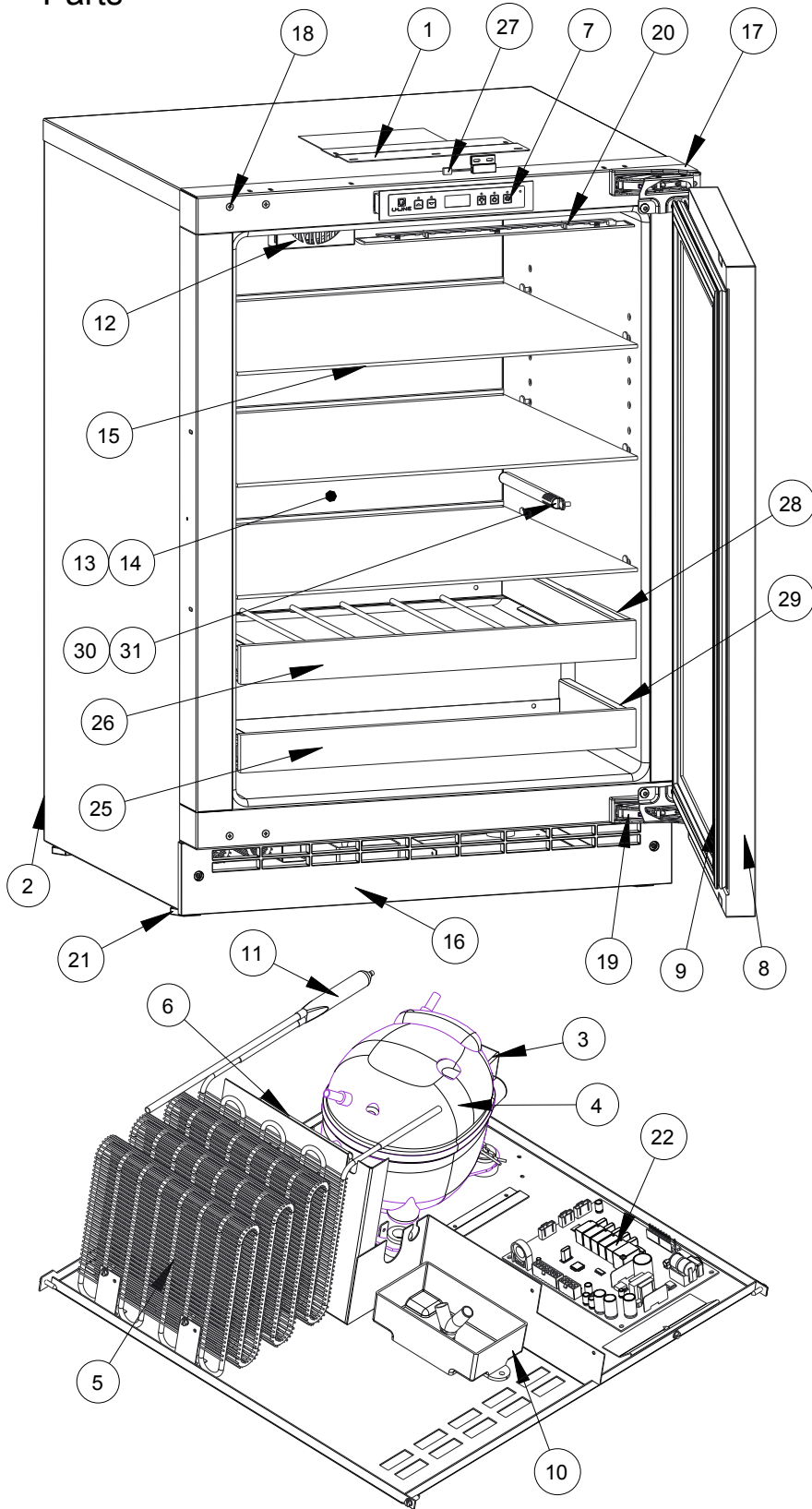

U-2224BEVINT-60B		
Item	Description	U-Line P/N
1	Anti tip brackets w/screws	80-54012-00
2	Back panel	80-54086-00
3	Compressor electricals only	80-54149-00
4	Compressor w/electricals	80-54150-00
5	Condenser	80-54043-00
6	Condenser fan w/screws	80-54014-00
7	Display module	80-54007-00
8	Door assembly w/o hinges	80-54163-00
9	Door gasket	80-54039-00
10	Drain pan w/double sided tape	80-54002-00
11	Drier	80-54055-00
12	Evap fan w/cover and screws	80-54151-00
13	Evaporator	80-54057-00
14	Evaporator cover	80-54042-00
15	Glass shelf (1) w/clips	80-54041-00
16	Grille w/ screws	80-54040-00
17	Hinge covers (2 pcs)	80-54001-00
18	Hinge mounting hole covers	80-54024-00
19	Hinges (2) w/screws and covers	80-54013-00
20	LED light strip and cover assy	80-54000-00
21	Leg Levelers (4)	80-54019-00
22	Main board (no wires or case)	80-54008-00
23	Packaging	80-54159-00
24	Power cord	80-54171-00
25	Rack assembly, bottom	80-54091-00
26	Rack assembly	80-54010-00
27	Reed switch	80-54134-00
28	Slide assembly, long	80-54047-00
29	Slide assembly, Short	80-54048-00
30	Thermistor (1 piece)	80-54006-00
31	Thermistor cover and pin	80-54023-00