

The road is long and dusty,  
but you've made a great first step.



Like you, the people at Monogram believe great kitchens start with great ideas.



When you begin your renovation or start construction of a new home, your brain is brimming with ideas. Ideas for how you want your kitchen to look, feel and function. But how do you bring them all together? The transition from bare walls to dream kitchen is not an easy feat. Often, the GE Monogram Collection™ can be the inspiration for a great kitchen design. Just as often, it's the means to the end. As you explore your options and compare appliances, we believe you'll discover Monogram alone meets your high standards for aesthetics and performance. The GE Monogram™ 48" Professional Range shown on the cover is a perfect example of this combination. The classic stainless steel design becomes a luminous focal point, but sophisticated styling is only half the story. It also gives you the precision and versatility that would be the envy of a four-star chef. Further, when it comes to performance, we leave nothing to chance. A specially trained technician will come to your home and perform the exclusive Monogram 40-Point Inspection. This includes precise temperature calibration of each oven and cooktop element. We'll tell you more about this incomparable range on page 9, but first, we want to share some exciting news with you. This year there are two major additions to the Monogram Collection: the new GE Monogram Digital Cooktop and the new GE Monogram Bottom-Mount Refrigerator.





The new Monogram Digital Cooktop is the first electric cooktop that truly rivals gas. And isn't it about time? After all, there are situations when it can be difficult to get a gas line into the kitchen. You may also prefer electricity because of its cleanliness and convenience. In any case, our Digital Cooktop is a real breakthrough. If you're

curious to find out more, turn to page 7. The new Monogram Bottom-Mount Refrigerator represents another major innovation. Space is at a premium in many of today's fashionable apartments and condominiums. A refrigerator that extends even an inch beyond the countertop may flaw the appearance of an otherwise brilliantly designed kitchen. So, if you lean toward the flush look, be aware there's a new standard. True flush. You might suspect we had to sacrifice interior storage space to accomplish this. Not so, as you'll see on page 5, where we discuss the interior in detail. The new bottom-mount is the perfect choice for some, but admittedly, not for everyone. Wouldn't it be a dull world if everyone liked exactly the same thing? As you browse through this catalog, you'll see that Monogram celebrates individualism with an expanded selection of refrigerators, professional ranges, hoods, cooktops, ovens, dishwashers, compactors and icemakers. Remember, too, there are two features that come with every Monogram appliance: GE's reputation for quality, and Monogram's unique package of customized services.





ZICS36NALH 36" Bottom-Mount Refrigerator; ZBD5900DSS Dishwasher; ZDP30N4YSS 30" Professional Range; ZX12B30YSS Backguard; ZV370YSS Professional Hood

Finally, there's a bottom-mount refrigerator that fits precisely into your renovation plans.

The Monogram™ Bottom-Mount Refrigerator is an exciting new addition to the Monogram Collection. It's 36" wide and 24-3/4" deep. Significantly, the latter dimension is precisely the depth of standard cabinets. Which means, of course, it's flush. Reaching this important standard without seriously limiting refrigeration and freezer space was a breakthrough in bottom-mount design. Other bottom-mounts often protrude 3/4" or more beyond the cabinets. This poses a dilemma for people who long for a flush look in their kitchen, but prefer the bottom-mount design for food storage. There's no longer any need to compromise. You can have both. When you open this new bottom-mount, you'll literally see the light. The special rear lighting system casts an even glow over everything inside. Gallon door bins, spill-proof split shelves and sealed snack pans give you new storage flexibility and capacity. Full extension slides in both compartments plus tough Lexan® windows on bins offer access others simply cannot equal. The two-tiered freezer also has full extension, pull-out slides. The full extension makes the freezer easier to load and makes your ice and frozen food easier to access.



*Designing a small kitchen is a daunting task, but with Monogram you can count on a happy ending. Just look at the result on the opposite page.*

Overall, we think you'll agree this new bottom-mount has more than ample capacity, which is enhanced by thoughtful design details. For more information turn to pages 38 and 39. If you have the luxury of space, you'll discover that two of these new bottom-mounts can be placed next to each other, one opening to the right and the other to the left. Ironically, in setting the standard for bottom-mounts, GE Monogram also created the ultimate side-by-side.



*ZEU36WMRABG 36" Digital Cooktop, ZV750SY Professional Hood, ZDW24ABB Wine Chiller and ZIC36NARH/ZIC36NALH Refrigerators*

GE Monogram proudly unveils the first electric cooktop that truly rivals gas.

If you're planning a new kitchen, it might be time for you to renovate your attitude toward the electric cooktop. The new Monogram™ Digital Cooktop surpasses yesterday's standards in accuracy, flexibility, cleanability. It can legitimately challenge the finest gas cooktops for overall performance. For example, this new cooktop offers a variety of burner configurations with precise, consistent temperatures. There's a dual 6-and-9" burner, plus a warming burner and a bridge burner for large dishes. Each burner delivers true, even heat over its entire surface, and has the lowest simmer capability available anywhere, gas or electric. Another important benefit is the effortless clean-up. The smooth ceramic surface has no knobs or moving parts. That means there are no crevices where food can drip or spill. It's an advantage you'll appreciate when guests are gone, the hour is late and you're the last one in the kitchen cleaning up. For more details, turn to page 17.



*Finally, you get to build your dream house. And you surprise everyone by choosing an electric cooktop. But this is no ordinary electric cooktop.*



*The new GE Monogram Digital Cooktop sets new standards for accuracy, flexibility and cleanability.*



ZDP48N4GWSS 48" Professional Range, ZX22B48ASS Backguard, ZV881WSS Professional Hood, ZMC1090BV Built-In Microwave Oven, ZBD5900DSS Dishwasher

Someday, the sizzle of salmon steaks will replace the whine of drills and pounding of hammers.

When that day comes, you'll be glad you built your new kitchen around a GE Monogram™ Professional Range. We offer 48", 36" and 30" models with corresponding professional hoods. But for now, let's just talk about the 48" model shown on these two pages. If you've always wanted an over-sized stainless steel professional range as the centerpiece of your kitchen, look no further. Monogram not only looks the part, it also plays the role brilliantly. It will perform flawlessly, responding precisely to every turn of a dial and touch of a button, handling the most demanding culinary challenges with ease and flair. And, because it's Monogram, you have an impressive array of options, starting with a choice of liquid propane or natural gas. In effect, you can customize your GE Monogram Professional 48" Range to accommodate your personal needs and preferences. How about six gas burners with either a grill or griddle? Or four gas burners with both grill and griddle? You can simmer at a delicate 500 BTUs, or boil and sear at 15,000 BTUs. All burners have electronic pilotless ignition. The 48" model also contains two self-cleaning electric ovens. One is a large convection oven. The other is a smaller, thermal oven. The smaller oven is especially popular with Monogram owners who enjoy baking, as it makes it very easy to proof yeast-leavened breads and pastries.



*Every great kitchen starts with a great idea. In this case, the inspiration was the GE Monogram Professional Range.*

And to top everything off, the Monogram 48" Professional Hood is the perfect complement to the range. The canopy of stainless steel creates a complete cooking center while efficiently drawing away the steam and vapors caused by cooking. Bright halogen lights illuminate the cooking area. The professional hood is available with infrared warming lights that help hold foods at perfect serving temperatures.



ZDP48N4GWSS 48" Professional Range, ZX22B48ASS Backguard, ZV881WSS Professional Hood

Master chefs stake their reputations  
on GE Monogram Professional Cooking Products.

Take Martin Yan, for example, the host of the acclaimed *Yan Can Cook* gourmet cooking show on PBS. (Martin is also the author of numerous cookbooks on Chinese and other Asian cuisines.) On his TV show Martin uses the Monogram™ 48" Gas Cooktop. For his home, he selected the GE Monogram™ 48" Professional Range. Here's what he said about them: "Be it in the TV studio or my own home kitchen, GE Monogram products are my most trusted partners. Elegant European design and efficient American engineering make the Monogram Collection reliable, durable, and a true joy to cook on. I especially love the even flame—no hot spots, and no surprises. Trust me, I already have more than enough surprises on *Yan Can Cook*." Martin added, "I can't say enough about the GE Monogram service people. They have calibrated each burner to perfection. When they came to my home for the 40-Point Inspection, I couldn't help but ask, 'Are you doing this just for me, because I'm a professional chef?' No, they said, we do this for all of our Monogram customers." The quality of GE Monogram gas cooktops and ranges does not change from model to model. But we do offer a wide choice of products because kitchen designs are so different. And because different customers prefer different features and configurations.



*Master Chef Martin Yan has won the James Beard Award for both "Best Television Cooking Show" and "Best Television Food Journalism".*

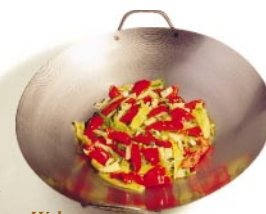

*The GE Monogram Wok. See page 57.*



ZDP30N4YSS 30" Professional Range, ZX12B30YSS Backguard, ZV370YSS Professional Hood

Kitchens come in all sizes.

So does the Monogram Professional Range.

It's a simple fact of life. Every kitchen doesn't have room for a 48" professional range, so you have to work with the space you have. And you shouldn't have to sacrifice your dream of "a professional look" just because you don't have a huge space. For this reason, Monogram™ also offers professional ranges in 36" and 30" models. One of them will slide smoothly into your kitchen plans regardless of space limitations. As you can see, the 30" professional range (shown on the opposite page) doesn't give an inch in terms of quality appearance. Both the 30" and 36" ranges have self-cleaning, convection mode electric ovens. They also have large windows and interior lights so you can always see what's going on inside. As you might assume, there's a slight difference in capacity (4.0 cu. ft. versus 4.3 cu. ft.), but you can expect superior performance from either one. Because of the convection mode, you'll be able to cook at lower temperatures, or cook in less time. Another advantage of convection mode is that you won't always need to preheat the oven. This will save time and conserve electricity.



*Our 36" range is available with six gas burners. All burners are equipped with electronic pilotless ignition.*



*Another option: four gas burners and a griddle. To assure uniform heat, the griddle is heated with a thermostatically-controlled gas burner.*



*And yet another option: four gas burners and a grill. Grill grates are smooth on one side and ridged on the other.*



*Fresh green onions – a delight to both the eye and the palate.*



ZGU48N6DWSS 48" Professional Cooktop, ZXC12B48WSS Backguard, ZV880WSS Professional Hood

GE Monogram Professional Cooktops  
have an answer to every culinary challenge.

Whether you're glazing, grilling, sautéing, or searing, Monogram™ professional cooktops are at your service. The 48" cooktop lets you choose from an arrangement of six gas burners with either a grill or griddle, or four gas burners with both a grill and griddle. The 36" model offers a choice of six burners or four burners with either a grill or a griddle. Whatever your selection, the cooktop leaves plenty of space for storage, open shelving, or anything else you want to keep within reach during meal preparation. Monogram's low 500 BTU setting softly simmers delicate sauces, while the high output of 15,000 BTUs delivers the intense heat necessary to boil a lobster quickly. Electronic pilotless ignition operates on either natural gas or liquid propane. Automatic reignition relights burners if the flame is inadvertently extinguished. Porcelainized cast-iron grates top all burners. Two-piece grill grates are similarly coated and reversible: smooth on one side for delicate foods such as a fillet of flounder; ridged on the other side for chops, steak and chicken. High-performance stainless steel provides an impeccably smooth griddle surface. Whether you're feeding a family of four, a few hundred friends, or a casual gathering with a number somewhere in between, Monogram cooktops virtually guarantee success.



*Talk about versatility—our 48" cooktop is available with four gas burners, a grill and a griddle.*



*Or a grill and six gas burners.*



*Or a griddle and six gas burners.*



*Delicious  
d or sautéed.*



8 7 6 5 4 3 2 1  
0 0 0 0 0 0 0 0

VEGA

VEGA

ZEU36WMRABC 36" Digital Cooktop, ZV750SY Professional Hood

“Cook with gas” was once the pledge of allegiance for every gourmet chef. Not any more.

Monogram™ digital cooktops are changing the way people think about electric cooking. Sure, electric cooking had a sizable following. Cleanability and convenience proved to be compelling reasons to choose electric cooking. But true gourmet cooks were unconvinced. We suspect they will remain skeptical, until the day we actually get them to try the Monogram Digital Cooktop. When they do, we believe they'll discover that electric cooking can be the equal of gas. The new Monogram Digital Cooktop actually has a lower simmer than gas. Our digital cooktops take full advantage of the latest technology, and combine it with a beautifully simple design. The glass cooktop is smooth. The easy-to-use controls (*sensing pads*) are printed right on the glass. For safety, there's a lock-out feature. When you touch a sensing pad, the designated burner responds to your command in seconds. Digital technology keeps temperature precise, as ribbon burners spread the heat out evenly. Just imagine, you can have a delicate sauce simmering on one burner, and at the same time, you can be steaming the asparagus, poaching the salmon fillets, and warming a loaf of bread.



*This 36" wide model has five burners plus a warmer burner.*

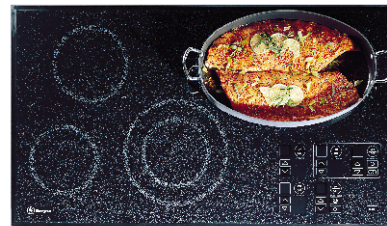

*This 36" wide model has five burners.*



*To accommodate smaller spaces, Monogram has developed a 30" model with four burners.*



*The fresher the dill leaves, the better the flavor.*



ZGU665BEXBG Gas Downdraft Cooktop

For all of you traditionalists, Monogram offers classic gas cooktops. Black or white. Updraft or downdraft.

The simple sophistication of GE Monogram™ gas cooktops blends beautifully with any architectural style or decorative theme. Select from the 36" updraft model or the downdraft version with its powerful vent. The vent slides out of sight when the cook's off duty. Thinking of an island or a peninsula? Perhaps you're designing a spot closer to the perimeter. Wherever you place them, Monogram Gas Cooktops perform brilliantly when you turn on the heat. Technology takes a decidedly supportive turn with these outstanding gas cooktops. Five responsive burners grace the sleek black or white surface. Two burners provide high-efficiency 11,000 BTU output, the other three deliver 6,500 BTU capacity. The controls are logically placed in the same configuration as the burners. The electronic pilotless ignition operates on natural or liquid propane gas. With the smooth surface of tempered glass and sealed burner bowls, spills have no place to go. So you just wipe them up. Durable, porcelain-enameled grates further simplify daily maintenance. When you begin a recipe, with Monogram, cleaning up will be the least of your concerns.



*Monogram believes that cooktops should be user friendly. Note how the control knobs are configured to match the placement of the burners.*



*The clipped leaves from basil thyme make a sweet-flavored aromatic tea.*



Now you see it. Now you don't.

Island and peninsula cooking centers are prime examples of this. If you install the cooktop in an island counter, for example, you obviously need a ventilation system to clear away the grease, steam and cooking odors. But where do you put it? The answer is, right behind the cooktop where it's almost invisible. That's because it retracts to a position that's nearly flush with the cooktop. What does protrude (*a mere 1/4 of an inch*) can be ordered in black, white or stainless to match the finish on your cooktop. Press the separate, remote switch and the sleek stainless steel venting grill rises to a height of 8-1/2" above the cooktop. The unit has a variable speed fan, of course, with a slide control. What's really important is that it has 500 CFMs (*Cubic Feet Per Minute*) of drawing power with a 3-1/4" by 10" rectangular duct, a combination that results in first class ventilation. To reduce noise in the kitchen, Monogram offers the option of remote blower placement (*with your choice of an exterior or interior kit*). Finally, the body of the vent is made of fashionable, durable stainless steel, which is easy to clean. The two filters are also easy to remove, clean and snap back into place. Stylish new Monogram Telescopic Downdrafts are available for both 30" and 36" gas or electric cooktops.



*When the new GE Monogram Telescopic Downdraft is not in use (as shown on the opposite page), no one will even notice it.*



*...ing with mushrooms can add flavor to nearly any recipe.*



*ZEW176Y Downdraft Vent Components (2), ZEW145V Halogen and Ribbon Component, ZGW124EN and ZGW125EN Gas Components*

If you haven't seen the perfect cooktop for your kitchen,  
design your own.



*Start designing. From left to right: Updraft Grill Component, Downdraft Vent Component, Gas Component, Downdraft Grill Component, Halogen and Ribbon Component.*

Individual cooking styles, whether traditional, eccentric or adventurous, call for a variety of cooking surface configurations. The versatile Monogram™ component cooktop system offers gas, grill, and halogen and ribbon components. Of course they can be mixed and matched to meet your personal needs. The gas component's burners are responsive and reliable. Both burners are topped with a one-piece cast-iron grate finished in porcelain enamel. The electric grill element, with its herringbone grid of porcelain-covered cast iron, brings the flavorful scents of an all-American cookout into your great American kitchen. A choice of downdraft or updraft ventilation systems gives you the flexibility to install these cooktops anywhere. The halogen and ribbon component pairs a 8" halogen element with a 6" ribbon element under a sleek glass surface.

These GE Monogram cooktop components give you maximum flexibility when designing a cooking center. Place them horizontally, vertically, in an island or on a countertop. The concept is to let you customize a cooktop exactly to your personal specifications.



*Basil is the major ingredient in classic Italian pesto sauce.*



ZET857SBSS 30" Double Oven

Decisions, decisions. Choosing just the right GE Monogram oven for your kitchen design and culinary style.

These European designed GE Monogram™ ovens have handsome tubular handles and large control knobs. With the European design, you have a choice of a single or double convection oven. The 30" double convection ovens deliver 3,000 watts for broiling and 2,500 watts for baking. Convection cooking modes also perform baking, roasting and broiling. Each oven has four racks that raise and lower among positions—including a Convection Floor Rack that has been designed to work with conventional shelves to provide flexibility and cooking performance. The baking element is concealed beneath the oven floor. This makes the oven easier to clean, and it also makes it safer to reach inside. There's also a 12-pass broiler, and a reflector. The reflector enhances broiling performance because it directs the heat down into the oven. GE Monogram ovens perform superbly at all points in the heat spectrum— including the lower temperatures. For example, there's a specific setting that will keep the oven just warm enough for proofing breads and other baked goods. There is also a preheat light to let you know when it's time to cook. Large windows give you a full view of your "work in progress." These windows are constructed of three layers of special glass. The glass reflects the heat inward while a fan recirculates air between the inner panes of glass. Cooking is more efficient and the oven door remains cool to the touch.

Monogram ovens are self-cleaning, of course. This function can be pre-set to take place at a time of your choosing. If you prefer just one oven, the GE Monogram single convection oven is the obvious choice. It has the same features as the double ovens.



Choose from stainless steel, stainless on black, black, or white. Whatever you choose, you'll be assured of exceptional performance.



*Flat leaf parsley has a stronger, richer flavor than curly leaf.*



ZET757BA 30" Double Oven

More ovens. Classic American styling outside.

Advanced technology on the inside.

If you prefer modern American styling to the European design, there are many reasons to select GE Monogram™. For example, most American-style ovens have only two heating elements: bake on the bottom, broil on the top. Ours has a third, which is set into the back wall of the oven surrounding the convection fan. The 30" ovens are equipped with an exceptionally powerful 4,000-watt, six-pass broiling system. This is ideal for rapid searing. (The 27" model has 3,400 watts.) All Monogram ovens have a meat probe to monitor meat temperatures during the convection roasting process. Those of you who bake will appreciate the precise control at lower temperatures.

The sophisticated electronic touch controls give you easy access to an array of functions. A conversion feature automatically reduces the time or temperature setting for conventional recipes to equivalent levels for convection cooking. Other controls enable you to choose between Celsius and Fahrenheit, and between a 12-hour or 24-hour time display. The ovens are self-cleaning and delivered complete with a broiler pan and a special roasting rack. The twin ovens fit nearly flush with standard depth cabinets, with only the door and control panels breaking the plane. Another option in a modern kitchen is a single convection oven, paired with a built-in microwave oven.



*These single and double convection ovens combine exceptional accuracy with touchpad controls. We have both 30" and 27" models.*



*Curly leaf parsley is known to be a natural breath freshener.*



ZTD910SB 30" Warming Drawer

Great food should never taste warmed over, even if it is.

If you've never had one of your exquisitely prepared meals fall victim to a guest's late arrival, you are among a rare and fortunate group. We can't do anything about late arrivals, but we can help keep your gourmet fare at or near perfection while you're waiting. In fact, the new Monogram™ Warming Drawer goes beyond just holding food at select temperatures, it will also assist you in preparing it. For example, you can maintain the moisture and taste of your side dish while you apply the finishing touch to your entree. The half rack is also a great convenience, and the infinite temperature settings include Proofing, which is ideal for dough to rise properly. The humidity control allows you to keep foods crisp or maintain food moisture. As an option, you can order a set of five pans. They allow you to customize the drawer to fit the different needs of different meals. **The Monogram Warming Drawer can be installed almost anywhere: under a cooktop, under a wall oven or in your kitchen island.** The Warming Drawer is available in two sizes, offering either 1.6 or 1.9 cubic feet of highly versatile space. The exterior finishes match the rest of the Monogram Collection, including stainless steel. There's also a trim kit, so you can install a trimless custom panel to match your cabinets or any special wall treatment.



*The half rack's design not only distributes heat evenly, it gives you fifty percent more surface area for stacking plates and food.*



*The GE Monogram Pan Set. See page 81.*



ZMC1095BB Built-In Microwave Oven, ZET737BA 30" Single Oven

Admit it. You can't get along without a microwave oven.  
Vital. Convenient. Versatile.

The Monogram™ built-in microwave offers not just one, but three ways to cook: microwave, convection, or both at the same time. The latter, a combination of microwave and convection heat, is ideal for roasting meats and poultry (*it's done faster, and comes out golden brown*). Other features include an entire cubic foot of capacity and ten power levels. A full 800 watts enable maximum cooking performance. The rugged stainless steel interior stands up to countless last-minute defrostings and late-night popcorn. One-touch sensor controls are easy to understand. There's even a control to turn down the volume of the signal that tells you the food is ready. The oven slides beautifully into a wall, installed alone or paired with a 27" single oven. Side trim pieces are provided with the product, allowing for installation over a 30" single oven. *Of course, Monogram offers a full-size, 1000-watt countertop model too. It opens with a horizontal door swing and can be built in. Although it doesn't have convection it has some unique features of its own. For example, it has a scrolling display that tells you what to do and when. Is space at a premium in your kitchen? Another option is our 800-watt compact microwave. It comes with smart features such as sensor controls, which take the guesswork out of reheating and defrosting. It's very user-friendly.*



*This 1.6 cubic foot countertop model can be built in.*



*This countertop model is available in stainless steel, black or white and can be mounted under a cabinet or built in.*



*The most flavorful rosemary leaves are found on the youngest stems.*



ZISB48DY 48" Built-In Refrigerator

Your Monogram built-in side-by-side can be a focal point.  
Or it can disappear into the woodwork.

Regardless of exterior treatment, the moment of truth always comes when you open the refrigerator door. Monogram™ excels in this department, too. *(You can read all about the interior on the next page.)* For now, let's just concentrate on the exterior. We have 36", 42" and 48" width built-in models. The depth of all models is 24-3/4", the same as standard cabinets. Because of the popularity of stainless steel, we recently introduced new 42" and 48" stainless steel models. With the gleaming stainless steel and tubular handles, the design is very European. Not unlike what you would see if you were visiting a fashionable villa in Tuscany. These models have a finely crafted appearance, with the wrapped steel coming all the way around the doors. You can order it with or without a dispenser (*crushed or cubed ice and chilled water*). The dispenser is black, very understated, the perfect accent for stainless steel. The Monogram built-in side-by-side refrigerators accept 1/4" and 3/4" door and grille panels. This allows you to customize "the look" to your personal taste. However, you can also order accessory panel kits in one of three classic colors: white, black or stainless steel. Refrigerators are available with or without a dispenser, and the dispensers are available in either black or white. The standard dispenser spans the width of the door, or it can be framed with a custom panel and secured with a collar. *To see these options, turn to pages 84 and 85.*



*The beauty of Monogram refrigeration is that it can be customized to achieve your design objective. You can make a bold statement with a professional style stainless steel model. Or you can blend your refrigeration unit into the decor with panels that match your cabinets or wall treatment.*



*Thinly sliced tangerine peel is a popular ingredient in Asian recipes.*



ZISS48DASS 48" Built-In Refrigerator

Designing the interior of a Monogram refrigerator deserves to be recognized as an art form.

Unless you already own a GE Monogram™ refrigerator, you probably think that no matter how big a refrigerator you buy, there's never enough room. The secret is to use all the interior space, intelligently. We started by perfecting the space in the door. By making the bins wide enough to accommodate big gallon jugs, you suddenly have a lot more shelf space in the main compartment. Take a few seconds to look at the interior of our new 48" stainless steel model (*note how the stainless steel wraps around the door*). When you open the door, it will remain motionless at 90 degrees, freeing both of your hands to store or remove items. See how nicely things fit? Shelves slide back to make room for taller items. The spill-proof shelves can be arranged and rearranged depending on your daily needs. The vegetable pans have individual humidity controls. They also glide open smoothly on full extension slides. The sealed snack pan has the same easy-glide, full extension convenience. Another nice touch is the wine caddy. Like the fresh food compartment, the freezer has been designed for maximum storage. It, too, has door bins and adjustable shelving. There are also two utility baskets for your bulkier items (*like the Thanksgiving turkey*). Both the freezer and fresh food compartments are equipped with individual temperature controls, which allow for precise calibration.



*The freezer contains the automatic icemaker, which provides cubed or crushed ice and chilled water through the freezer door.*



*Kiwi makes a delightfully edible garnish.*



ZFSB27DASS Free-Standing Refrigerator

When we hear people say “Free-standing refrigerators have no place in a well-designed kitchen,” we can only assume they haven’t seen ours.

The Monogram™ Free-Standing Refrigerator occupies its space with style and dignity. It was the first refrigerator from GE to be completely encased in stainless steel. It blends timeless design with professional beauty, and easily becomes the focal point in a well-designed kitchen. Take hold of those twin tubular handles and you’ll feel the strength of true reliability. The full-length handles and the black dispenser (*with Water By Culligan™*) accent the pristine exterior. Now open the doors and see how many ways the spacious 27 cubic foot interior adapts to different shapes and sizes. The spill-proof glass shelves can be easily adjusted to suit your needs. The door bins hold gallon-size containers and are also adjustable. Monogram’s unique system of individual compartments helps keep delicate foods fresh and crisp. The freezer is also remarkably spacious. The wire shelves and door bins can be adjusted to your ever-changing storage needs. If a built-in refrigerator doesn’t fit your design plans, the sleek appearance and obvious quality of the Monogram stainless steel refrigerator should make it your number one choice.



*A unique system of individual compartments helps keep delicate foods fresh and crisp.*



*Fresh mint is terrific in everything from mint juleps to tabouli salad.*



ZIC36NARH Bottom-Mount Refrigerator

You can have it all. The convenience of a bottom-mount.  
The sleek look of a true built-in.

If you long for the flush look in refrigeration, know that there's a new standard. *It's the new GE Monogram™ 36" Bottom-Mount Refrigerator.* True flush exterior with unmatched interior design. True flush means Monogram lines up evenly with your cabinet faces, regardless of your choice of exterior style (see pages 88 and 89). This also remains true even if you elect to have custom panels made to match or accent your overall kitchen doors. Monogram's true beauty, however, lies behind those flush doors. Open the top compartment and the first thing you'll see is *everything*. All your fresh foods and beverages are stored in their special places. The dual rear lighting system provides an evenly diffused light throughout the compartment. Shelves are spill-proof and adjustable. Your fresh fruits and snacks are stored safely in sealed bins to assure freshness. But you can still see them, because the lids (and the shelves) are all *see-through*. By the way, all lids *lock in place* in an open position until you decide to close them. The door bins are split, the ones on top are adjustable, the bottom level is oversized. The lower is designed to hold larger containers including gallon jugs. As for the freezer compartment, it has two tiers. It also has full-extension slides for easier access. This slide-out feature is a nice convenience when you're accessing frozen food or restocking.



*Here you can see how two of our new bottom-mounts were installed to create the ultimate "side-by-side".*



*It's fun to experiment with garnish. This delicious duo is made up of carrot and leek.*



Two entertaining ideas from GE Monogram.

Wine Chiller. Beverage Center.

GE Monogram™ can help make entertaining a little easier. Both the Wine Chiller and Beverage Center can be tucked beneath almost any counter. The one in the beach house or guest cottage, or the one in the den or family room. The Monogram wine chiller holds 50 bottles of your choosing until just the right moment. There's a soft interior light visible through the glass door. So, your wine is not only within easy reach, you can also see what you're reaching for. You can have this light on all the time, or keep the interior dark until you open the door. Full-width racks slide out to facilitate selection and storage. Thermostat settings range from the low 40s to mid 60s. There are subtle, but important, differences between the beverage center and the wine cooler. The beverage center is designed to accommodate virtually all types of beverage containers, including cans, quart bottles and those huge two-liter plastic containers. The wine chiller is specifically designed for wine and champagne bottles. Both have handsome tubular handles and stainless steel trim around the clear glass door. Both offer you a choice between a white or black finished case. And both share a number of performance features such as adjustable temperature control and automatic defrosting.

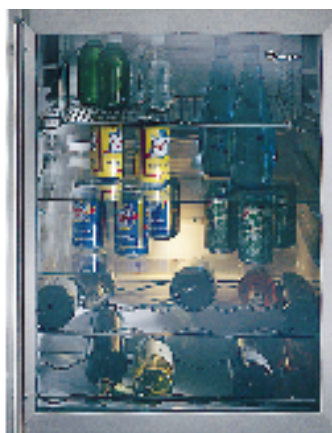

*GE Monogram Wine Chillers (bottom) and Beverage Centers have 6.1 cubic feet of capacity and can be installed free-standing or built-in. Door swing is reversible.*

*If your butter sauce recipe calls for white wine, try substituting champagne.*





The GE Monogram Icemaker. Quality ice.  
And lots of it.

The ability to make large quantities of ice should be a given. We believe it's the quality of the ice that really sets an icemaker apart. At Monogram™, we utilize a process known as *fractional freezing*. That is, we move water over a cold plate until it freezes. The remaining water is then discarded, resulting in clear, commercial quality ice. You can count on this hardworking perfectionist to provide up to 50 pounds of ice, every day. Day after day. That means you'll always have plenty of ice on hand, whether you're having a party or just need to fill up a cooler. Not only does this GE Monogram Icemaker know when to make ice, it knows when to stop, shutting off automatically when the 25-pound capacity bin is full. The aesthetically pleasing design works as either a free-standing or built-in unit. A reversible door swing adds even more installation flexibility, providing easy access to the ice bin. It's perfect for the kitchen, den or wet bar.



*The Monogram Icemaker is available in stainless steel, black or white. Decorative option: if you prefer, 3/4" panels can be installed to coordinate or contrast with your existing cabinetry.*



*A wedge of lime added to ice water creates a natural cocktail.*



Designing a kitchen is never easy.

With GE Monogram Dishwashers, you get solutions instead of problems.

We believe this GE Monogram™ dishwasher design has set a new standard. The full-length sweep of simple lines, without the usual access panel at the bottom to interrupt the view, is only part of what makes this design so appealing. The full-wrap stainless steel look extends the architectural impression around the molded edges for trimless simplicity. On electronic models, the touch pad controls are discreetly positioned into a slightly contoured panel. Electro-mechanical models feature sturdy rotary knobs. On some models, the concealed door handle is incorporated into the control panel so smoothly, it practically disappears. Other models feature a traditional, full-width control panel, door handle and access panel. Cycle-option features can include as many as 19 different programmable combinations. According to the dish load, you can select exactly the right mix of cleaning capabilities from options such as heat and water levels, convection drying, delayed start, and wash time. There's also an auto-memory feature so you don't have to re-program every time. Other control features include a series of status lights that indicate the various stages in the wash cycle. There's a child-lock setting for obvious reasons, and some of the models have a sanitization cycle where the water reaches 170° Fahrenheit.



*GE Monogram Dishwashers are available in stainless steel, black, or white. They're also designed to accept customized panels to match adjacent cabinetry.*



*The French like their avocado seasoned with Vinaigrette sauce.*



Behind the elegant appearance, there's a hard worker ready to carry a big load. Tough when it must be. Gentle when it should be.

We believe good kitchen help should never be hard to find. And it should be intelligent, experienced and very quiet. GE Monogram™ dishwashers are as strong on performance as they are on looks. That's why we give you a myriad of features. It's important that you can safely clean everything from fine porcelain to greasy pots. It's also important that you can see everything, which is why we've included an interior light in the back right corner. You also need loading versatility. You'll be particularly pleased with our rack design. For example, all the dish tines on the lower level fold down to accommodate different heights and shapes. And the tines are *dog-legged* to secure heavier pieces like stoneware. On the upper rack there are four cup shelves and special prongs designed to keep your fragile stemware safe. Some models have a stainless steel interior (left), while others have a white Permatuf® interior (right). A series of multiple filters, including one of fine mesh, removes food during the wash cycle. Multiple wash jets reach every crevice of dishes and cups. Mid- and lower-level wash arms ensure full cleaning coverage on all sides of cookware. And with this industrial strength cleaning, you still get state-of-the-art quiet. GE Monogram's carefully engineered systems effectively reduce sound levels with three kinds of insulation. After the wash cycle, the hot water rinse and condensate drying system minimize the spotting of dishes.

Some models have a delay-start option. This defers dishwashing for up to eight hours. Long after you're out the door (*or asleep*), your GE Monogram Dishwasher will quietly go to work.



*The five-level wash system sprays water in five different directions, covering virtually every part of each dish, eliminating the need for pre-rinsing.*



*Poach nectarines in vanilla-flavored syrup. Chill on ice. Serve with a puree of fresh raspberries.*



ZCG3500DSS 12" Stainless Steel Compactor

GE Monogram Compactors. A mere 12 inches wide.  
Exerts up to 5,000 pounds of compressive force.

Let's talk about pressure. Because that's what you need in a trash compactor. Especially in cosmopolitan kitchens where space is at a premium and the garbage is only picked up once a week. The Monogram™ compactor compresses trash to one-twelfth of its original volume. That's the equivalent of 14 filled receptacles packed into a single bag. Operation is safe and simple. When you're ready to start, a removable key locks the compactor, turns on the motor, and assures that the drawer remains locked throughout operation. When you open the drawer, the compactor becomes non-operational. The ram cannot function with the drawer open. Although it can exert up to 5,000 pounds of force, the Monogram compactor is, itself, remarkably compact. A mere 12" wide. During installation, the base of the compactor can be aligned with the base of surrounding cabinets, just like other built-in appliances. Monogram's simple, understated design blends the control panel discreetly with adjacent cabinetry. Out of sight, out of mind. Just where trash should be.

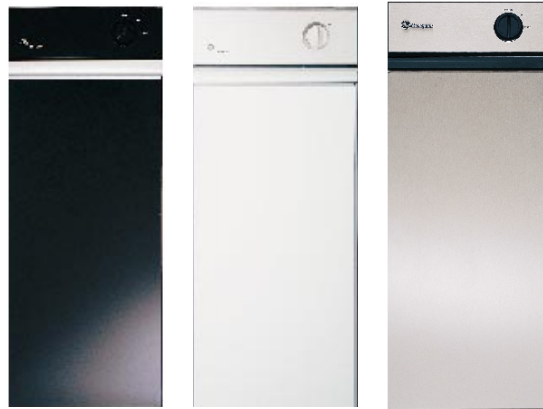

*The GE Monogram Compactor is available in black, white, or stainless steel. It can also accept a 3/4" trimless panel for a more integrated design.*

*Italians like to stuff their onions with risotto.*



How do you choose which Monogram appliances are best for you?



It's easy to fall in love with the professional range, then turn the page and see all the advantages offered by the professional cooktops and built-in ovens. Not so long ago it was easy for gourmet cooks to choose between gas and electric cooktops. Now we've seriously clouded that issue by introducing the Monogram™ Digital Electric Cooktop. Refrigeration is another area ripe for debate. We thought we'd never see the equal to our side-by-side designs. Then we turned around and developed the new Monogram bottom-mount. Is it superior to our own side-by-side models? For some people, yes. For some people, no. And isn't that really what's important? That you have a choice. That you have the opportunity to consider all the options before making your decision.



Having so many choices may be frustrating at times, but the satisfaction you'll feel when you stand in your new kitchen knowing you made the right decisions will make it all worthwhile. That feeling of accomplishment is absolutely priceless. On the preceding pages we have shown how different GE Monogram appliances look in different kitchens. We did this to help you visualize how they might look in your kitchen. But every kitchen is unique. Every inch has to be planned and measured. A new kitchen is a complex undertaking. On the following pages we've isolated each category of appliance, demonstrated most of the options and given you precise specifications and measurements.



## 48" Professional Ranges

All Monogram™ 48" professional ranges contain two electric ovens with a combined capacity of 6.3 cubic feet and offer a choice of gas cooktop arrangements: four burners with a grill and griddle, or six burners with either a grill or griddle.

### Main Oven:

**Convection mode.** The 4.3 cu. ft., 27"-wide oven offers a convection mode which allows cooking at a lower temperature or in less time and often eliminates the need to preheat the oven.

**Baking and broiling performance.** An eight-pass, 4000-watt broil element and a ten-pass, 5000-watt bake element span the cooking area, providing consistent, even heat.

**Oven racks.** Three removable racks slide smoothly on ball-bearing rollers. All three racks can be used to convection bake multiple dishes simultaneously.

**Self-clean.** Simply press a button and turn a dial to set the self-clean cycle. The door locks automatically and remains locked throughout the five-hour pyrolytic process. The gas burners may be used during the cleaning cycle.

**A lighted view.** Observe cooking progress through the large window with two interior lights.

### Companion Oven:

**Proficiency on a smaller scale.** The 2.0 cubic foot, 12"-wide companion oven offers thermal baking and broiling, plus a function for proofing yeast-leavened breads and pastries.

**Baking and broiling performance.** A 3600-watt broil element and a 2800-watt bake element handle smaller-volume cooking.

**Oven racks.** Three rack positions allow the adjustment of two racks. A broiler pan is included.

**A lighted view.** A large window and an interior light allow a view of cooking progress.

**Additional features and installation information.** See pages 96 and 97.

**Professional venting and backguards.** These ranges can be installed against a wall with one of two required backguards: the 12" model or the 22" model with a high warming shelf. These backguards, and a 1200 CFM hood, must be installed with the cooktop. The ranges require 1-1/2" trim when positioned in an island or against a non-combustible wall surface such as tile or brick.



**ZDP48N4GWSS** 48" Dual Fuel Professional Range  
(natural gas)

**ZDP48LAGWSS** 48" Dual Fuel Professional Range  
(liquid propane)

**Four gas burners.** Dual-ring burners ensure even heat delivery. Infinite controls maintain precise temperature settings between the low 500 BTU simmer and the maximum output 15,000 BTU setting.

**Cast-iron burner grates.** Porcelainized burner grates form a large cooking area. Lift-out burner bases are also coated with porcelain enamel. Electronic ignition with automatic reignition. Pilotless burners are automatically reignited, should the flame be inadvertently extinguished (except in simmer mode).

**Slide-out drip trays.** The stainless steel drip trays beneath the burners, grill and griddle collect spills, grease and crumbs. The drip tray beneath the grill and griddle features two removable liners that lift out for easy cleaning.

**18,000 BTU grill.** The two-piece cast-iron grill grate is fully coated with porcelain enamel. The grate is reversible, with a smooth surface for delicate foods and a ridged side for hardy meats. The grill slopes forward, allowing drippings to flow into the drip tray liner. Ceramic briquettes provide even heating and a stainless steel cover keeps the grill clean when not in use.

**18,000 BTU griddle.** 3/8" thick stainless steel forms the surface of this high-performance griddle. The griddle also slopes forward, allowing liquids to flow into the drip tray liner. The thermostatically-controlled griddle ensures even heating and consistent results. A stainless steel cover keeps the griddle clean when not in use.



**ZX1B48WSS**  
1-1/2" Trim Piece

**ZX12B48WSS**  
12" Backguard

**ZX22B48ASS**  
22" Backguard with  
Warming Shelf



**ZDP48N6RWSS** 48" Dual Fuel Professional Range  
(*natural gas*)

**ZDP48L6RWSS** 48" Dual Fuel Professional Range  
(*liquid propane*)

**Six gas burners.** Dual-ring burners ensure even heat delivery. Infinite controls maintain precise temperature settings between the low 500 BTU simmer and the maximum output 15,000 BTU setting.

**Cast-iron burner grates.** Porcelainized burner grates form a large cooking area. Lift-out burner bases are also coated with porcelain enamel.

**Electronic ignition with automatic reignition.** Pilotless burners are automatically reignited, should the flame be inadvertently extinguished (except in simmer mode).

**Slide-out drip trays.** The stainless steel drip trays beneath the burners and grill collect spills, grease and crumbs. The drip tray beneath the grill features one removable liner that lifts out for easy cleaning.

**18,000 BTU grill.** The two-piece cast-iron grill grate is fully coated with porcelain enamel. The grate is reversible, with a smooth surface for delicate foods and a ridged side for hardy meats. The grill slopes forward, allowing drippings to flow into the drip tray liner. Ceramic briquettes provide even heating and a stainless steel cover keeps the grill clean when not in use.



**ZDP48N6DWSS** 48" Dual Fuel Professional Range  
(*natural gas*)

**ZDP48L6DWSS** 48" Dual Fuel Professional Range  
(*liquid propane*)

**Six gas burners.** Dual-ring burners ensure even heat delivery. Infinite controls maintain precise temperature settings between the low 500 BTU simmer and the maximum output 15,000 BTU setting.

**Cast-iron burner grates.** Porcelainized burner grates form a large cooking area. Lift-out burner bases are also coated with porcelain enamel.

**Electronic ignition with automatic reignition.** Pilotless gas burners are automatically reignited, should the flame be inadvertently extinguished (except in simmer mode).

**Slide-out drip trays.** The stainless steel drip trays beneath the burners and griddle collect spills, grease and crumbs. The drip tray beneath the griddle features one removable liner that lifts out for easy cleaning.

**18,000 BTU griddle.** 3/8" thick stainless steel forms the surface of this high-performance griddle. The griddle slopes forward, allowing liquids to flow into the drip tray liner. The thermostatically-controlled griddle ensures even heating and consistent results. A stainless steel cover keeps the griddle clean when not in use.



## 36" Professional Ranges

All Monogram™ 36" professional ranges offer a choice of gas cooktop arrangements: four burners with a grill or griddle, or with six burners.

**Convection mode.** The 4.3 cu. ft., 27"-wide electric oven offers a convection mode which allows cooking at a lower temperature or in less time and often eliminates the need to preheat the oven.

**Baking and broiling performance.** An eight-pass, 4000-watt broil element and a ten-pass, 5000-watt bake element span the cooking area, providing consistent, even heat.

**Oven racks.** Three removable racks slide smoothly on ball-bearing rollers. All three racks can be used to convection bake multiple dishes simultaneously. A porcelain-coated broiler pan and rack are included.

**Self-clean.** Simply press a button and turn a dial to set the self-clean cycle. The door locks automatically and remains locked throughout the five-hour pyrolytic process. The gas burners may be used during the cleaning cycle.

**A lighted view.** A large window and two interior lights allow a view of cooking progress.

**Additional features and installation information.** See pages 98 and 99.

**Professional venting and backguards.** These ranges can be installed against a wall with one of two required backguards: the 12" model or the 22" model with a high warming shelf. These backguards, and a 600 CFM minimum hood, must be installed with the cooktop. The ranges require 1-1/2" trim when positioned in an island or against a non-combustible wall surface such as tile or brick.



**ZX1B36WSS**  
1-1/2" Trim Piece

**ZX12B36WSS**  
12" Backguard

**ZX22B36ASS**  
22" Backguard with  
Warming Shelf



**ZDP36N6WSS** 36" Dual Fuel Professional Range  
(natural gas)

**ZDP36L6WSS** 36" Dual Fuel Professional Range  
(liquid propane)

**Six gas burners.** Dual-ring burners ensure even heat delivery. Infinite controls maintain precise temperature settings between the low 500 BTU simmer and the maximum output 15,000 BTU setting.

**Cast-iron burner grates.** Porcelainized cast-iron burner grates form a large cooking area. Lift-out burner bases are also coated with porcelain enamel.

**Electronic ignition with automatic reignition.** Pilotless burners are automatically reignited, should the flame be inadvertently extinguished (except in simmer mode).

**Slide-out drip tray.** The stainless steel drip tray collects spills, grease and crumbs.



**ZDP36N4RWSS** 36" Dual Fuel Professional Range  
*(natural gas)*

**ZDP36LARWSS** 36" Dual Fuel Professional Range  
*(liquid propane)*

**Four gas burners.** Dual-ring burners ensure even heat delivery. Infinite controls maintain precise temperature settings between the low 500 BTU simmer and the maximum output 15,000 BTU setting.

**Cast-iron burner grates.** Porcelainized burner grates form a large cooking area. Lift-out burner bases are also coated with porcelain enamel.

**Electronic ignition with automatic reignition.** Pilotless burners are automatically reignited, should the flame be inadvertently extinguished (except in simmer mode).

**Slide-out drip tray.** The stainless steel drip tray beneath the burners and grill collects spills, grease and crumbs. A stainless steel drip liner beneath the grill lifts out for easy cleaning.

**18,000 BTU grill.** The two-piece cast-iron grill grate is fully coated with porcelain enamel. The grate is reversible, with a smooth surface for delicate foods and a ridged side for hardy meats. The grill slopes forward, allowing drippings to flow into the drip tray liner. Ceramic briquettes provide even heating and a stainless steel cover keeps the grill clean when not in use.



**ZDP36N4DWSS** 36" Dual Fuel Professional Range  
*(natural gas)*

**ZDP36LADWSS** 36" Dual Fuel Professional Range  
*(liquid propane)*

**Four gas burners.** Dual-ring burners ensure even heat delivery. Infinite controls maintain precise temperature settings between the low 500 BTU simmer and the maximum output 15,000 BTU setting.

**Cast-iron burner grates.** Porcelainized burner grates form a large cooking area. Lift-out burner bases are also coated with porcelain enamel.

**Electronic ignition with automatic reignition.** Pilotless burners are automatically reignited, should the flame be inadvertently extinguished (except in simmer mode).

**Slide-out drip tray.** The stainless steel drip tray beneath the burners and griddle collects spills, grease and crumbs. A stainless steel drip liner beneath the griddle lifts out for easy cleaning.

**18,000 BTU griddle.** This high-performance griddle is has a 3/8" thick stainless steel surface. The griddle slopes forward, allowing liquids to flow into the drip tray liner. The thermostatically-controlled griddle ensures even heating and consistent results. A stainless steel cover keeps the griddle clean when not in use.



## 30" Professional Ranges

The Monogram™ 30" professional gas ranges feature a stainless steel facade and tubular stainless steel handle. There are four burners and an oven capacity of 4 cubic feet. This dual-fuel model combines gas heat on the cooktop with an electric convection oven below.

**Convection mode.** The 4 cu. ft. electric oven offers a convection mode which allows cooking at a lower temperature or in less time and often eliminates the need to preheat the oven.

**Four gas burners.** Dual-ring burners ensure even heat delivery. Infinite controls maintain precise temperature settings between the low simmer and maximum output setting.

**Large commercial knobs.** Easy grip knobs let you set the flame quickly, surely.

**Oven racks.** Three removable oven racks slide smoothly on ball-bearing rollers. All three racks can be used to convection bake multiple dishes simultaneously. A porcelain-coated broiler pan and rack are included.

**A lighted view.** A large window and two interior lights allow a view of cooking in progress.

**Additional features and installation information.** See pages 98 and 99.



**ZDP30N4YSS** 30" Dual Fuel Professional Range  
*(natural gas)*

**ZDP30LAYSS** 30" Dual Fuel Professional Range  
*(liquid propane)*

**Baking and broiling performance.** An eight-pass, 4000-watt broil element and a six-pass, 3700-watt bake element span the cooking area, providing consistent, even heat.

**Cast-iron burner grates.** Porcelainized cast-iron burner grates form a large cooking area. Lift-out burner bases are also coated with porcelain enamel.

**Self-clean.** Simply press a button and turn a dial to set the self-clean cycle. The door locks automatically and remains locked throughout the five-hour pyrolytic process. The gas burners may be used during the cleaning cycle.

**Electronic ignition with automatic reignition.** Pilotless burners are automatically relighted should the flame be extinguished inadvertently (except in simmer mode).

**Slide-out drip tray.** The stainless steel drip tray collects spills, grease and crumbs.

**Professional venting and backguards.** These ranges can be installed against a wall with one of two required backguards: the 12" model or the 22" model with a high warming shelf. These backguards, and a 600 CFM hood, must be installed with the cooktop. The ranges require 1-1/2" trim when positioned in an island or against a non-combustible wall surface such as tile or brick.



**ZX1B30YSS**  
Dual Fuel  
1-1/2" Trim Piece

**ZX12B30YSS**  
Dual Fuel  
9" Backguard

**ZX22B30ASS**  
Dual Fuel  
22" Backguard with  
Warming Shelf



**ZXWK22Y Wok Accessory**

The Monogram wok, 22" in diameter, is fashioned from high-carbon steel, the choice of professional chefs. An aluminum lid with wooden handle completes the wok, which is supported by a stainless steel ring that locks into place on the burner grate. Approved for use on Professional Ranges and Cooktops only.



## 48" Professional Cooktops

All Monogram™ 48" professional cooktops offer a choice of gas cooking surface arrangements: four burners with a grill and griddle, or six burners with either a grill or griddle. To ensure proper installation, all professional cooktops must be ordered with an appropriate backguard. See backguard options below.

**Wide range of performance.** Heat output from the gas burners extends from an exceptionally low 500 BTUs, at the simmer setting, to a maximum of 15,000 BTUs at the highest setting.

**Precise control.** Infinite gas burner controls glide between low and high settings, allowing precise temperature selection. Power levels for the grill vary from simmer through low, medium, and high. The griddle heats at selected temperatures from low through 450° F., with infinite settings in between.

**Slide-out drip trays.** The stainless steel drip trays beneath the burners, grill and/or griddle collect spills, grease and crumbs. The drip tray beneath the grill and/or griddle features two removable liners that lift out for easy cleaning.

**Additional features and installation information.** See pages 100 and 101.

**Professional venting and backguards.** These cooktops can be installed against a wall with one of two required backguards: the 12" model or the 22" model with a high warming shelf. These backguards, and a 1200 CFM hood, must be installed with the cooktop. The cooktops require 1-1/2" trim when positioned in an island or against a non-combustible wall surface such as tile or brick.



**ZXC1B48BSS**  
1-1/2" Trim Piece



**ZXC12B48WSS**  
12" Backguard



**ZXC22B48ASS**  
22" Backguard with  
Warming Shelf



**ZGU48N4GWSS** 48" Professional Cooktop (*natural gas*)

**ZGU48LAGWSS** 48" Professional Cooktop (*liquid propane*)

**Four gas burners.** Dual-ring burners ensure even heat delivery. Infinite controls maintain precise temperature settings between the low 500 BTU simmer and the maximum output 15,000 BTU setting.

**Cast-iron burner grates.** Porcelainized burner grates form a large cooking area. Lift-out burner bases are also coated with porcelain enamel.

**Electronic ignition with automatic reignition.** Pilotless burners are automatically reignited, should the flame be inadvertently extinguished (except in simmer mode).

**Slide-out drip trays.** The stainless steel drip trays beneath the burners, grill and griddle collect spills, grease and crumbs. The drip tray beneath the grill and griddle features two removable liners that lift out for easy cleaning.

**18,000 BTU grill.** The two-piece cast-iron grill grate is fully coated with porcelain enamel. The grate is reversible, with a smooth surface for delicate foods and a ridged side for hardy meats. The grill slopes forward, allowing drippings to flow into the drip tray liner. Ceramic briquettes provide even heating and a stainless steel cover keeps the grill clean when not in use.

**18,000 BTU griddle.** 3/8" thick stainless steel forms the surface of this high-performance griddle. The griddle also slopes forward, allowing liquids to flow into the drip tray liner. The thermostatically-controlled griddle ensures even heating and consistent results. A stainless steel cover keeps the griddle clean when not in use.



**ZGU48N6RWSS** 48" Professional Cooktop (*natural gas*)

**ZGU48L6RWSS** 48" Professional Cooktop (*liquid propane*)

**Six gas burners.** Dual-ring burners ensure even heat delivery. Infinite controls maintain precise temperature settings between the low 500 BTU simmer and the maximum output 15,000 BTU setting.

**Cast-iron burner grates.** Porcelainized burner grates form a large cooking area. Lift-out burner bases are also coated with porcelain enamel.

**Electronic ignition with automatic reignition.** Pilotless burners are automatically reignited, should the flame be inadvertently extinguished (except in simmer mode).

**Slide-out drip trays.** The stainless steel drip trays beneath the burners and grill collect spills, grease and crumbs. The drip tray beneath the grill features a removable liner that lifts out for easy cleaning.

**18,000 BTU grill.** The two-piece cast-iron grill grate is fully coated with porcelain enamel. The grate is reversible, with a smooth surface for delicate foods and a ridged side for hardy meats. The grill slopes forward, allowing drippings to flow into the drip tray liner. Ceramic briquettes provide even heating and a stainless steel cover keeps the grill clean when not in use.



**ZGU48N6DWSS** 48" Professional Cooktop (*natural gas*)

**ZGU48L6DWSS** 48" Professional Cooktop (*liquid propane*)

**Six gas burners.** Dual-ring burners ensure even heat delivery. Infinite controls maintain precise temperature settings between the low 500 BTU simmer and the maximum output 15,000 BTU setting.

**Cast-iron burner grates.** Porcelainized burner grates form a large cooking area. Lift-out burner bases are also coated with porcelain enamel.

**Electronic ignition with automatic reignition.** Pilotless burners are automatically reignited, should the flame be inadvertently extinguished (except in simmer mode).

**Slide-out drip trays.** The stainless steel drip trays beneath the burners and griddle collect spills, grease and crumbs. The drip tray beneath the griddle features a removable liner that lifts out for easy cleaning.

**18,000 BTU griddle.** 3/8" thick stainless steel forms the surface of this high-performance griddle. The griddle slopes forward, allowing liquids to flow into the drip tray liner. The thermostatically-controlled griddle ensures even heating and consistent results. A stainless steel cover keeps the griddle clean when not in use.



## 36" Professional Cooktops

All Monogram™ 36" professional cooktops offer a choice of gas cooking surface arrangements: four burners with a grill or griddle, or with six burners. To ensure proper installation, all professional cooktops must be ordered with an appropriate backguard. See backguard options below.

**Wide range of performance.** Heat output from the gas burners extends from an exceptionally low 500 BTUs, at the simmer setting, to a maximum of 15,000 BTUs at the highest setting.

**Precise control.** Infinite gas burner controls glide between low and high settings, allowing precise temperature selection. Power levels for the grill vary from simmer through low, medium, and high. The griddle heats at selected temperatures from low through 450° F., with infinite settings in between.

**Slide-out drip tray.** The stainless steel drip tray beneath the burners, grill and/or griddle collect spills, grease and crumbs. The drip tray beneath the grill and/or griddle features a removable liner that lifts out for easy cleaning.

**Additional features and installation information.** See pages 100 and 101.

**Professional venting and backguards.** These cooktops can be installed against a wall with one of two required backguards: the 12" model or the 22" model with a high warming shelf. These backguards, and a 600 CFM minimum hood, must be installed with the cooktop. The cooktops require 1-1/2" trim when positioned in an island or against a non-combustible wall surface such as tile or brick.



**ZGU36N6YSS** 36" Professional Cooktop (*natural gas*)

**ZGU36L6YSS** 36" Professional Cooktop (*liquid propane*)

**Six gas burners.** Dual-ring burners ensure even heat delivery. Infinite controls maintain precise temperature settings between the low 500 BTU simmer and the maximum output 15,000 BTU setting.

**Cast-iron burner grates.** Porcelainized burner grates form a large cooking area. Lift-out burner bases are also coated with porcelain enamel.

**Electronic ignition with automatic reignition.** Pilotless burners are automatically reignited, should the flame be inadvertently extinguished (except in simmer mode).

**Slide-out drip tray.** The stainless steel drip tray beneath the burners collects spills, grease and crumbs.



**ZXC1B36BSS**

1-1/2" Trim Piece

**ZXC12B36YSS**

12" Backguard

**ZXC22B36ASS**

22" Backguard with  
Warming Shelf



**ZGU36N4RYSS 36" Professional Cooktop (natural gas)**

**ZGU36LARYSS 36" Professional Cooktop (liquid propane)**

**Four gas burners.** Dual-ring burners ensure even heat delivery. Infinite controls maintain precise temperature settings between the low 500 BTU simmer and the maximum output 15,000 BTU setting.

**Cast-iron burner grates.** Porcelainized burner grates form a large cooking area. Lift-out burner bases are also coated with porcelain enamel.

**Electronic ignition with automatic reignition.** Pilotless burners are automatically reignited, should the flame be inadvertently extinguished (except in simmer mode).

**Slide-out drip tray.** The stainless steel drip tray beneath the burners and grill collects spills, grease and crumbs. The drip tray beneath the grill features a removable liner that lifts out for easy cleaning.

**18,000 BTU grill.** The two-piece cast-iron grill grate is fully coated with porcelain enamel. The grate is reversible, with a smooth surface for delicate foods and a ridged side for hardy meats. The grill slopes forward, allowing drippings to flow into the drip tray liner. Ceramic briquettes provide even heating and a stainless steel cover keeps the grill clean when not in use.



**ZGU36N4DYSS 36" Professional Cooktop (natural gas)**

**ZGU36LADYSS 36" Professional Cooktop (liquid propane)**

**Four gas burners.** Dual-ring burners ensure even heat delivery. Infinite controls maintain precise temperature settings between the low 500 BTU simmer and the maximum output 15,000 BTU setting.

**Cast-iron burner grates.** Porcelainized burner grates form a large cooking area. Lift-out burner bases are also coated with porcelain enamel.

**Electronic ignition with automatic reignition.** Pilotless burners are automatically reignited, should the flame be inadvertently extinguished (except in simmer mode).

**Slide-out drip tray.** The stainless steel drip tray beneath the burners and griddle collects spills, grease and crumbs. The drip tray beneath the griddle features a removable liner that lifts out for easy cleaning.

**18,000 BTU griddle.** 3/8" thick stainless steel forms the surface of this high-performance griddle. The griddle slopes forward, allowing liquids to flow into the drip tray liner. The thermostatically-controlled griddle ensures even heating and consistent results. A stainless steel cover keeps the griddle clean when not in use.



## 48" Professional Hoods

A Monogram™ 48" wall-mounted hood perfectly complements your GE Monogram 48" professional range or cooktop and creates a complete cooking center.

**Powerful, efficient ventilation.** The 304-grade stainless steel canopy houses a powerful ventilation system that efficiently removes steam and the by-products of cooking.

**Variable-speed fan.** A single knob controls the variable-speed fan, which draws steam, heat and grease particles away from the cooking surface, into the filters and through the vent system.

**High visibility.** Two halogen lamps, mounted under the hood, illuminate the cooking surface below.

**1200 CFM fan.** The variable-speed fan blower operates at a maximum venting power of 1200 cubic feet per minute.

**Heat lamps.** Models ZV881WSS and ZV891YSS include two 250-watt infrared heat lamps that help maintain prepared foods and baked goods at serving temperatures. This hood is the ideal complement to the 22" backguard which features a high warming shelf.

**Removable filters.** During ventilation, two stainless steel, baffle-type filters trap airborne grease particles. A pair of handles simplifies removal of each of the washable, dishwasher-safe filters.

**Transition piece.** Two styles of stainless steel transition pieces are available for use with the 48" hood. Both convert to a 10" round duct, one for vertical application and one for horizontal application.

ZX48AY, for vertical application

ZX48BY, for horizontal application

**Additional features and installation information.** See pages 102 and 103.

*Note: We recommend ordering the installation instructions (pub. no. 49-8816) in advance to accurately plan final framing needs, electrical and ductwork locations. Simply log on to our website at [www.monogram.com](http://www.monogram.com) for further information.*



**ZV880WSS** 48" Professional Tapered-Sided Hood

**ZV881WSS** 48" Professional Tapered-Sided Hood with Heat Lamps

**Duct covers.**

ZX6DC48WSS, 6" Duct Cover

ZX12DC48WSS, 12" Duct Cover



**ZV890YSS** 48" Professional Straight-Sided Hood

**ZV891YSS** 48" Professional Straight-Sided Hood with Heat Lamps

**Duct covers.**

ZX6DC49YSS, 6" Duct Cover

ZX12DC49YSS, 12" Duct Cover

## 36" and 30" Professional Hoods

A Monogram™ 36" wall-mounted hood perfectly complements your GE Monogram 36" professional range or cooktop or your 30" professional range and creates a complete cooking center.

**Powerful, efficient ventilation.** The 304-grade stainless steel canopy houses a powerful ventilation system that efficiently removes steam and the by-products of cooking.

**Variable-speed fan.** A single knob controls the variable-speed fan, which draws steam, heat and grease particles away from the cooking surface, into the filters and through the vent system.

**High visibility.** Halogen lamps, mounted under the hood, illuminate the cooking surface below. 36" models offer two lamps and 30" models offer one lamp.

**600 CFM fan.** The variable-speed fan blower operates at a maximum venting power of 600 cubic feet per minute.

**Heat lamps.** Models ZV671WSS, ZV681YSS and ZV371YSS include a 250-watt infrared heat lamp that helps maintain prepared foods and baked goods at serving temperatures. These hoods are the ideal complement to the 22" backguard which features a high warming shelf.

**Removable filters.** During ventilation, a stainless steel, baffle-type filter traps airborne grease particles. A pair of handles simplifies removal of the washable, dishwasher-safe filter.

**Additional features and installation information.** See pages 102 and 103.

*Note: We recommend ordering the installation instructions (pub. no. 49-8816) in advance to accurately plan final framing needs, electrical and ductwork locations. Simply log on to our website at [www.monogram.com](http://www.monogram.com) for further information.*



**ZV670WSS** 36" Professional Tapered-Sided Hood

**ZV671WSS** 36" Professional Tapered-Sided Hood with Heat Lamp

**Duct covers.**  
ZX6DC36WSS, 6" Duct Cover  
ZX12DC36WSS, 12" Duct Cover



**ZV680YSS** 36" Professional Straight-Sided Hood

**ZV681YSS** 36" Professional Straight-Sided Hood with Heat Lamp

**Duct covers.**  
ZX6DC38YSS, 6" Duct Cover  
ZX12DC38YSS, 12" Duct Cover



**ZV370YSS** 30" Professional Straight-Sided Hood

**ZV371YSS** 30" Professional Straight-Sided Hood with Heat Lamp

**Duct covers.**  
ZX6DC30YSS, 6" Duct Cover  
ZX12DC30YSS, 12" Duct Cover



## Digital Cooktops

GE Monogram™ digital cooktops take full advantage of advanced technology and put it together with stunning design. These cooktops are available in 36" and 30" widths with digital sensing pads attractively integrated into the cooktop glass.

**Easy care.** Ceramic glass surface with beveled edges, trimless design, and no knobs can be quickly sponged clean.

**Digital controls.** All controls are logically clustered in one corner and mounted on the underside of the glass surface. Sensors read the resistance of your finger to activate the controls through the glass.

**Instantaneous response.** The touch of a pad provides instant visual response. Ribbon elements can be adjusted from low to high, with nine heat levels in-between.

**Simmer capability.** Each burner delivers true, even heat over its entire surface and has the lowest simmer capability available.

**Bridge burners.** An additional burner "bridges" two 7" elements to create a larger and exceptionally practical cooking area.

**Installation options.** GE Monogram 36" and 30" digital cooktops can be installed in an island, or in a countertop extending from a wall. They may also be installed with a telescopic downdraft vent in either a 36" or 30" width. This is ideal for island installations.

**Additional features and installation information.** See pages 104 and 105.



**ZEU36WMRABG 36" Black Digital Cooktop**

**Five burners, seven configurations.** Ribbon elements include a 6" 1200-watt burner, a 6"/9" 1000-watt/2500-watt burner and a 250-watt warming burner that keeps covered food moist at just the right temperature. An additional elongated cooking area is created by two 7" elements in the right center and rear area when combined with the "bridge" element.

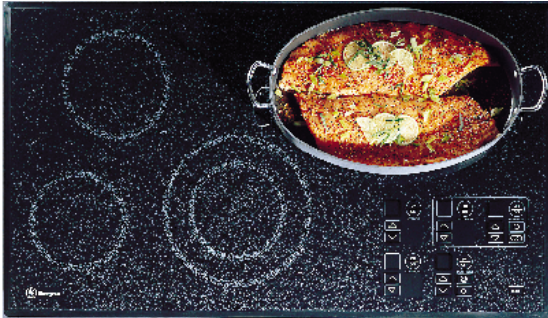

**ZEU365ABG 36" Black Digital Cooktop**

**Five burners, seven configurations.** Ribbon elements include one 6" 1200-watt element, one 6-1/2" 1400-watt element, and one 1000-watt/2500-watt element, varying from 6" to 9" in diameter. An additional elongated cooking area is provided by two 7" elements in the right center and rear area, when combined with the "bridge" element.

**Indicator lights.** Five surface lights, adjacent to the controls, glow when the burners are active and remain lit until the surface cools.



**ZEU304ABG 30" Black Digital Cooktop**

**Four burners, six configurations.** Ribbon elements include one 6-1/2" 1400-watt element, and one 1000-watt/2500-watt element varying from 6" to 9" in diameter. An additional elongated cooking area is created by two 7" elements in the right center and rear area, when combined with the "bridge" element.

**Indicator lights.** Four surface lights, adjacent to the controls, glow when the burners are active and remain lit until the surface cools.



## Electric Cooktops

Advanced technology, under glass: From fast-responding halogen and ribbon burners to highly efficient operating systems, Monogram™ electric cooktops are designed for superb performance.

**Easy care.** Tempered glass surfaces can be quickly sponged clean.

**Recessed cooktop.** The cooktop is recessed and sealed by a steel surround, for a nearly flush installation.

**Bridge burner.** An additional burner “bridges” two other burners to create a larger and exceptionally practical cooking area.

**Installation options.** GE Monogram 36" electric cooktops can be installed in a countertop extending from a wall, in an island, or with a telescopic downdraft vent.

**Additional features and installation information.** See pages 104 and 105.



**ZEU676YSB 36" Black Ribbon Cooktop**

**Seven cooking areas.** Six ribbon elements vary from 6" to 8" in diameter. A seventh cooking area is created by two 7" elements and the “bridge” element that connects them, forming an elliptical burner that’s ideal for larger pans.

**Indicator lights.** Six surface lights, adjacent to the controls, glow when the burners are active and remain lit until the surface cools. When any burner is activated, a separate light indicates that the cooktop is “on.”

**Rapid response.** The turn of a front-mounted dial provides visual response within seconds. The elements can be adjusted from low to high with infinite heat levels in between.



**ZEU669AWW 36" White Halogen and Ribbon Cooktop**

**ZEU668ABB 36" Black Halogen and Ribbon Cooktop**

**Six cooking areas.** Two halogen elements and three ribbon elements range from 6" to 9" in diameter. A sixth cooking area is created by the two 7" ribbon elements and a "bridge" element which connects them, forming an elliptical burner that's ideal for larger pans.

**Indicator lights.** Five surface lights, adjacent to the controls, glow when the burners are active and remain lit until the surface cools. When any burner is activated, a separate light indicates that the cooktop is "on."

**Instantaneous response.** The turn of a dial provides instant visual response and rapid heat-up. The two halogen elements offer ten precise heat settings and the three ribbon elements can be adjusted from low to high, with infinite heat levels in-between.



## Gas Cooktops

Monogram™ gas cooktops combine a sleek appearance with sophisticated technology for outstanding performance.

**Perimeters, peninsulas, and islands.** GE Monogram 36" gas cooktops can be installed in an island, or in a 24" countertop extending from a wall.

**Easy care.** The tempered glass surface sponges clean quickly.

**Black and white.** All models are offered in black and white to coordinate with kitchen decor.

**Front-mounted controls.** Knobs are positioned to correspond logically with burner locations, allowing fast and precise control of cooking power.

**Additional features and installation information.** See pages 106 and 107.

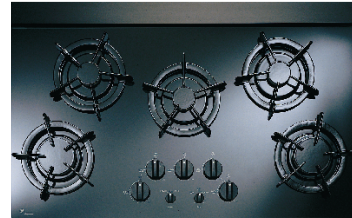

**ZGU665WEX 36" White Gas Downdraft Cooktop**

**ZGU665BEX 36" Black Gas Downdraft Cooktop**

**Integrated venting system.** The powerful, retractable downdraft vent is integrated with the cooktop. The vent features variable speed controls and a removable filter for easy cleaning.

**Sealed burner bowls.** Since all burner bowls are sealed to the cooktop, spills remain on the surface and are easily wiped away.

**Electronic ignition.** Pilotless electronic ignition responds quickly and performs reliably.

**High-efficiency burners.** Burners can be converted from natural gas to liquid propane operation, using conversion orifices packed with cooktop. Two burners have a maximum output of 11,000 BTUs and three perform up to 6,500 BTUs, providing fast heat-up and consistent heat delivery.

**Cast-iron grates.** Durable cast-iron burner grates are coated with porcelain enamel and are easily cleaned.

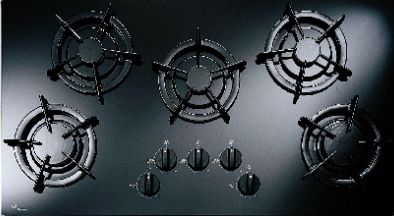

**ZGU651ES 36" White Gas Updraft Cooktop**

**ZGU650ES 36" Black Gas Updraft Cooktop**

**Unobtrusive depth.** The updraft cooktop is only 3" high, allowing installation over cabinets, drawers and shelves without infringing upon storage space.

**Sealed burner bowls.** Since all burner bowls are sealed to the cooktop, spills remain on the surface and are easily wiped away.

**Electronic ignition.** Pilotless electronic ignition responds quickly and performs reliably.

**High-efficiency burners.** Burners can be converted from natural gas to liquid propane operation, using conversion orifices packed with cooktop. Two burners have a maximum output of 11,000 BTUs and three perform up to 6,500 BTUs, providing fast heat-up and consistent heat delivery.

**Cast-iron grates.** Durable cast-iron burner grates are coated with porcelain enamel and are easily cleaned.

**Installation option.** This cooktop can also be installed with a 36" telescopic downdraft vent.



## Hood



**ZV750SY 36" Stainless Steel Hood**

**360 CFM fan.** The four-speed fan blower operates at a maximum venting power of 360 cu. ft. per minute.

**Halogen lighting.** Four halogen lights illuminate the cooking surface and include a low light/night light setting.

**Six lighting levels.** Discreet, push-button controls allow halogen lighting to be set at six levels of intensity.

**Removable filters.** During ventilation, three filters trap airborne grease particles. The filters are removable, washable, and dishwasher-safe. An indicator light signals when the filter needs cleaning.

**Timer.** The fan can be set for automatic shut-off after 5, 10, or 20 minutes of operation.

**Additional features and installation information.** See pages 108 and 109.

## Telescopic Downdraft Systems

The stylish Monogram 30" or 36" telescopic downdraft systems perfectly complement the Monogram 30" and 36" gas and electric cooktops, respectively. Simply press the separate, remote switch and the sleek venting grill rises to a height of 8-1/2" above the cooktop. They are perfect for island and peninsula cooking centers because they retract to a position that's nearly flush with the cooktop. The body of the vent is made of fashionable stainless steel, with the vent cover (when retracted) available in black, white, or stainless steel.



### **Powerful, efficient ventilation.**

Efficiently remove steam and the by-products of cooking with a 3-1/4" by 10" rectangular duct and a durable, stainless steel vent. And to reduce noise in the kitchen, Monogram offers

the option of a remote blower placement, with your choice of an exterior or interior kit.

**Variable-speed fan.** A slide knob controls the variable-speed fan, which draws steam, heat and grease particles away from the cooking surface into the filters and through the vent system.

**500 CFM fan.** The variable-speed fan blower operates at a maximum venting power of 500 cubic feet per minute.

**Removable filters.** During ventilation, two baffle-type filters trap airborne grease particles. Both filters are easily removable and dishwasher safe.

**Additional features and installation information.** See pages 108 and 109.

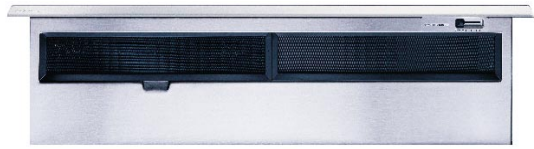
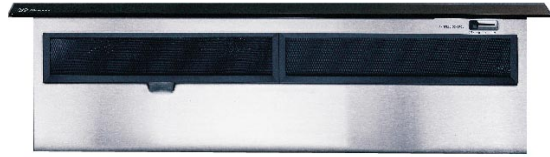
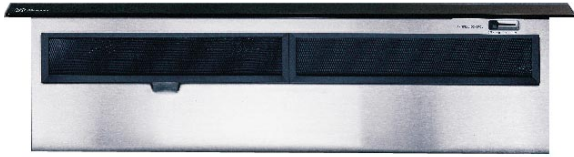

**ZVB36BBBB** 36" Black Telescopic Downdraft Vent

**ZVB36WBWW** 36" White Telescopic Downdraft Vent

**ZVB36SBSS** 36" Stainless Steel Telescopic Downdraft Vent

**ZVB30BBBB** 30" Black Telescopic Downdraft Vent

**ZVB30WBWW** 30" White Telescopic Downdraft Vent

**ZVB30SBSS** 30" Stainless Steel Telescopic Downdraft Vent



## Component Cooktops

The Monogram™ Component Cooktop System offers gas, grill, and halogen and ribbon components that can be mixed or matched for a variety of gas and electric cooking surfaces. The modular system lends itself to virtually endless configurations. Components can be installed alone, in pairs, or as a series. Build them into an island or a perimeter countertop. Arrange them side by side, horizontally or vertically, or even end to end.

**Additional features and installation information.** See pages 110 thru 113.



**ZGW124EN**  
Gas Component *(controls on right)*

**ZGW125EN**  
Gas Component *(controls on left)*

**Twin burners.** Two gas burners are topped by a one-piece cast-iron grate finished in easily cleaned porcelain enamel. One burner provides 6,000 BTUs, the other 10,500 BTUs.

**Electronic ignition with automatic reignition.** Pilotless burners are automatically reignited should the flame be inadvertently extinguished.

**Natural gas only.** Gas components are not convertible to liquid propane gas operation.

**Flexible design.** This component offers your choice of left-hand or right-hand controls to suit various component system configurations.

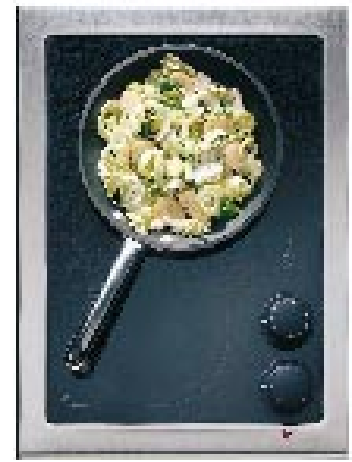

**ZEW145V**  
Halogen and Ribbon Component

**Seamless design.** One 8" halogen element and one 6" ribbon element are paired under a smooth glass surface that's simple to clean. The patterned glass resists scratches and fingerprints. The entire cooktop is recessed and neatly sealed by a stainless steel surround that helps contain spills and facilitates cleaning.

**Instantaneous response.** A turn of the dial for either element provides instant visual response and rapid heat-up. Lights next to the controls indicate a hot surface and, when not lit, signal that the surface is cool.

**Precise control.** The halogen element offers ten heat levels. When using a 240-volt power source, the element provides 1,800 watts of electricity and at 208 volts, 1,350 watts. The ribbon element provides 1,200 watts at 240 volts, 900 watts at 208 volts.



**ZEW155N**  
Updraft Grill Component

**1,750-watt grill.** Topped with a herringbone grate of porcelainized cast-iron, the grill element is divided into two halves, each with individual controls.

**Cleanability.** The durable, cast-iron grill grate is coated with porcelain enamel and is removable for easy cleaning.

**Indicator light.** A light next to the controls indicates that the component is in operation.



**ZEW166Y**  
Downdraft Grill Component

**2,800-watt grill.** Topped with a herringbone grate of porcelainized cast-iron, the grill element is divided into two halves, each with individual controls.

**Downdraft vent.** The vent automatically starts when the grill is turned on, drawing smoke and cooking by-products outside through the filter. A variable-speed control allows for fan-speed adjustment.

**Cleanability.** The durable, cast-iron grill grate is coated with porcelain enamel and is removable for easy cleaning. A porcelain-coated cast-iron grate covers the vent and is also removable for cleaning.

**Indicator light.** A light next to the controls indicates that the component is in operation.



**ZEW176Y**  
Downdraft Vent Component

**Downdraft vent.** The vent effectively draws smoke and cooking by-products outside through the filter. A variable-speed control allows for fan-speed adjustment.

**Versatile design.** This vent can be used with either the gas or the halogen and ribbon components.

**Cleanability.** A porcelain-coated cast-iron grate covers the vent and cleans easily. The removable filter is washable, which extends filter life and allows the component's venting and filtration system to work most efficiently.



## Microwave Ovens



**ZMC1095SB** Stainless Steel Built-In Microwave/Convection Oven

**ZMC1095WB** White Built-In Microwave/Convection Oven

**ZMC1095BB** Black Built-In Microwave/Convection Oven

**Cooking performance.** Ten power levels and a full 800-watts enable maximum cooking performance.

**Three modes.** The microwave/convection oven offers three ways to cook: microwave, convection, or a combination of both.

**Sensor cooking.** An electronic sensor actually senses the steam that escapes as food cooks. Sensor controls take the guesswork out of microwave cooking by automatically adjusting the cooking time to accommodate the type and amount of food being prepared.

**Electronic touch controls.** Electronic controls are operated by a simple touch. You can hold foods at a specified temperature after cooking is complete and the oven can be programmed to delay cooking for up to 24 hours.

**Capacity.** An entire cubic foot cavity provides ample cooking space and a removable wire rack provides cooking flexibility.

**Durability.** The stainless steel interior shines through years of use.

**Installation flexibility.** The built-in microwave/convection oven can be installed alone in a cabinet or wall, or built in above a GE Monogram™ 27" single oven. Side trim pieces are provided for installation with a 30" single oven.

**Additional features and installation information.** See pages 120 and 121.



**ZE1660SA** Stainless Steel Microwave Oven

**Cooking performance.** Ten power levels and a full 1000 watts enable maximum cooking performance.

**Sensor cooking.** An electronic sensor actually senses the steam that escapes as food cooks. Sensor controls take the guesswork out of microwave cooking by automatically adjusting the cooking time to accommodate the type and amount of food being prepared.

**Electronic touch controls.** Electronic controls are operated by a simple touch. You can hold foods at a specified temperature after cooking is complete and the oven can be programmed to delay cooking for up to 24 hours.

**Capacity.** An entire 1.6 cu. ft. cavity provides ample cooking space and a removable wire rack provides cooking flexibility.

**Installation options.** To conserve countertop space, this microwave oven can be built into a wall or built in above a GE Monogram 27" or 30" single oven.



**ZEM200WY** White Compact Microwave Oven

**ZEM200GY** Black Compact Microwave Oven with Greystone Case

**ZEM200SY** Stainless Compact Microwave Oven with Greystone Case

**Cooking performance.** Ten power levels and a full 800 watts enable maximum cooking performance.

**Sensor cooking.** An electronic sensor actually senses the steam that escapes as food cooks. Sensor controls take the guesswork out of microwave cooking by automatically adjusting the cooking time to accommodate the type and amount of food being prepared.

**Electronic touch controls.** Electronic controls require only a touch of a pad to pop corn and reheat beverages. Express Cook, Auto Defrost and Instant-On Controls bring a remarkable level of speed and convenience to microwave cooking.

**Capacity.** This .9 cubic foot microwave is an ideal addition to any kitchen or entertainment room.

**Installation options.** To conserve countertop space, this compact microwave oven can be built into a wall, built in above a GE Monogram 27" single oven, or mounted under a cabinet.



## Convection Ovens with European-Design

A blend of refined styling and remarkable performance, Monogram™ 30" convection ovens can be installed nearly flush with the wall or cabinetry.

**True convection.** A dedicated third heating element in the back wall combines with the convection fan to provide even heat and a consistent temperature throughout the oven. The advantages provided are more even browning and the ability to bake or roast on multiple racks simultaneously saving time and energy.

**Self-clean.** Both ovens are programmable to self-clean at preset times. The oven door locks automatically when the self-cleaning cycle begins. If desired, cook in one oven while the other cleans.

**2,500-watt baking.** Following European tradition, the 2,500-watt bake element is concealed beneath the oven floor, saving space and simplifying ash removal after the self-clean cycle.

**Proofing mode.** A dedicated low-temperature setting provides the gentle heating needed for proofing baked goods.

**A lighted view.** Each oven has dual interior lights. Viewing windows allow continuous monitoring of cooking progress.

**Convection floor rack.** The Monogram Convection Floor Rack, working in combination with the conventional oven rack, is perfect for convection cooking a wide variety of foods. Chocolate chip cookies, pizzas, pies—even foods requiring additional cooking space such as large roasts or turkeys can be easily handled.

**Convection roasting rack.** This rack, when used with the broiler pan and grid, provides proper air circulation for excellent convection roasting performance.

**Additional features and installation information.** See pages 114 and 115.



**ZET857SBSS** 30" Stainless Steel Double Convection Oven

**ZET857DBSB** 30" Stainless Steel on Black Double Convection Oven

**ZET857BBBB** 30" Black Double Convection Oven

**ZET857WBWW** 30" White Double Convection Oven

**3,000-watt broiling.** In both the upper and lower ovens, three elements combine to form a powerful 3,000-watt, 12-pass broiler system that provides exceptionally even heating. A reflector above the system directs heat downward, enhancing broiler performance.

**Five racks, five positions.** Four adjustable racks in each oven, combined with the convection floor rack, gives you five total racks allowing full use of oven capacity.



**ZET837SBSS** 30" Stainless Steel Single Convection Oven

**ZET837DBSB** 30" Stainless Steel on Black Single Convection Oven

**ZET837BBBB** 30" Black Single Convection Oven

**ZET837WBWW** 30" White Single Convection Oven

**3,000-watt broiling.** Three elements combine to form a powerful 3,000-watt, 12-pass broiler system that provides exceptionally even heating. A reflector above the system directs heat downward, enhancing broiler performance.

**Five racks, five positions.** Four adjustable racks in each oven, combined with the convection floor rack, gives you five total racks allowing full use of oven capacity.



## Convection Ovens with Traditional American-Design

Monogram® convection ovens, in 30" and 27" widths, can be installed nearly flush in a wall or cabinetry. With advance electronics and sleek, contemporary styling, these ovens are valuable assets to any kitchen.

**True convection.** A dedicated third heating element is located in the back wall surrounding the fan which effectively circulates heated air, helping to produce the uniform results for which convection cooking is renowned.

**Electronic touch controls.** Controls activated by a gentle touch allow you to quickly select the desired cooking function: convection bake or roast, variable broil, 24-hour delay bake, timed cook, or warm mode. Simply press touchpads to set the oven, clock or timer, or to select the self-clean cycle.

**Intelligent convenience.** The convection conversion feature automatically reduces the time or temperature settings for conventional recipes to the appropriate levels required for convection cooking.

**Individual preference.** Program your preference for Celsius or Fahrenheit temperature scales, and for 12-hour or 24-hour time display.

**Meat thermometer.** The internal temperature of meats can be monitored during convection roasting. The temperature probe can be used in either the upper or lower oven.

**Roasting perfection.** The roasting rack divides the oven into equal parts, properly positioning food and helping to ensure excellent convection performance.

**Self-clean.** The ovens are programmable to self-clean at preset times. The oven door locks automatically when the self-cleaning cycle begins. The double oven models let you cook in one oven, while the other cleans.

**Baking element.** The baking element, in the style of European design, is concealed beneath the oven floor. This arrangement makes clean-up of spills easier.

**Proofing mode.** A specific low-temperature setting provides gentle heating for proofing of baked goods.

**Additional features and installation information.** See pages 116 and 117.



**ZET757WA** 30" White Double Convection Oven

**ZET757BA** 30" Black Double Convection Oven

**4000-watt broiling.** Exceptionally powerful 4,000-watt broil elements in both ovens are ideal for the rapid searing of meats. These six-pass elements provide consistent, even heat for uniform cooking.

**Independent controls.** Separate controls for the upper and lower ovens allow independent operation of the cooking and self-cleaning modes. A control lock-out prevents unwanted operation or use by children.

**Five racks, seven positions.** Each oven includes five racks that are interchangeable between the ovens. Seven embossed rack positions in each oven allow full use of oven capacity.



**ZEK757WA** 27" White Double Convection Oven

**ZEK757BA** 27" Black Double Convection Oven

**Independent controls.** Separate controls for the upper and lower ovens allow independent operation of the cooking and self-cleaning modes. A control lock-out prevents unwanted operation or use by children.

**Three racks, four positions.** Each oven includes three racks that are interchangeable between ovens. Four embossed rack positions in each oven allow full use of oven capacity.



**ZET737WA** 30" White Single Convection Oven

**ZET737BA** 30" Black Single Convection Oven

**4000-watt broiling.** An exceptionally powerful 4,000-watt broil element is ideal for the rapid searing of meats. The six-pass element provides consistent, even heat for uniform cooking.

**Five racks, seven positions.** The oven includes five racks and has seven embossed rack positions, allowing full use of the oven's capacity.



**ZEK737WA** 27" White Single Convection Oven

**ZEK737BA** 27" Black Single Convection Oven

**Three racks, four positions.** The oven includes three racks and has four embossed rack positions, allowing full use of the oven's capacity.

## Warming Drawers

Monogram™ warming drawers are designed to keep foods at or near perfection until time to serve. They're available in 30" and 27" widths, and offer 1.6 or 1.9 cubic feet of highly versatile space. The exterior finishes match the rest of the Monogram Collection, and a 1/4" trim kit is also available for trimless custom panels.

**Infinite temperature settings.** Monogram offers infinite temperature settings, offering you expanded flexibility. From a "proof" setting (approximately 75°), which is ideal for dough to rise properly, to a "high" setting (approximately 230°), which is perfect for warming plates.

**Humidity control.** An accurate humidity control keeps foods crisp, or maintains food moisture by simply opening or closing the vent.

**Half rack.** This half rack's design not only distributes heat evenly, but also provides fifty percent more surface area for stacking plates and food.

**Full extension drawer.** A full extension drawer allows better access, and it's removable for easy cleanup.

**Installation variety.** All 30" and 27" Monogram warming drawers are UL approved for use with all Monogram wall ovens and cooktops, with the exception of the ZEU304 cooktop that must be installed with the 27" model. All models also feature flush installation.

**Additional features and installation information.** See pages 118 and 119.



**ZTD910WB** 30" White Warming Drawer

**ZTD910BB** 30" Black Warming Drawer

**ZTD910SB** 30" Stainless Steel Warming Drawer



**JXPN1 Five-Pan Accessory Set**

**Five-pan accessory set.** A set of five pans can be ordered, allowing a choice of sizes—one for virtually any size meal: one large, 14-quart pan; two medium, 6-quart pans; and two small, 3-quart pans.

**ZKD910WB 27" White Warming Drawer**

**ZKD910BB 27" Black Warming Drawer**

**ZKD910SB 27" Stainless Steel Warming Drawer**



## Built-In Refrigerators

These Monogram® built-in refrigerators require door and grille panels. Optional accessory panel kits allow you to create a white, black, or stainless steel facade to coordinate with the theme chosen for your kitchen. You may choose custom handles to complement your decor, tubular stainless steel handles, or the full-length contemporary-style handles furnished with the refrigerator. See pages 36 and 37 for information on kits. These built-in refrigerators offer an intelligently designed storage system. Glass shelves and modular bins can be quickly repositioned to suit ever-changing storage needs.

**Independent controls.** Fresh-food and freezer sections have separate controls to allow proper temperature calibration for each compartment.

**Chilled water and ice.** GE Monogram offers built-in refrigerator models with a black or white dispenser that neatly spans the width of the door. With a light press of the dispenser's cushioned pad, chilled water, ice cubes, or crushed ice are delivered through the freezer door.

**Convenient access.** Automatic door-holds keep each door motionless at 90 degrees and 130 degrees, making food storage and removal easy.

### Fresh food compartment:

**Abundant storage.** Four adjustable shelves and five adjustable door bins offer extensive storage flexibility. One shelf slides back to make room for tall containers; another drops down for additional space when needed.

**Wine holder.** The wine caddy suspends securely from a shelf edge to cradle a single bottle.

**Vegetable, snack, and dairy compartments.** Two full-width vegetable pans with individual humidity controls, as well as a sealed snack pan, glide open with ease. Special storage space on the door keeps dairy items fresh and accessible.

### Freezer compartment:

**Abundant storage.** The freezer offers flexible space with adjustable bins on the door and shelves in the interior that can be arranged to suit storage requirements. Two utility baskets extend fully, providing easy access to bulk storage.

**Icemaker.** The freezer is outfitted with an automatic icemaker that shuts off when the ice bin is full. The large capacity bin is easily removed for access to bulk ice.

**Additional features and installation information.** See pages 122 and 123.



**ZISW48DY** 48" Built-In Refrigerator with White Dispenser

**ZISB48DY** 48" Built-In Refrigerator with Black Dispenser

**ZIS48NY** 48" Built-In Refrigerator without Dispenser

**Accessory panels.** All 48" refrigerators require door and grille panels. These 1/4" panel kits are available for installation in standard trim:

### White.

ZISW48DY White Dispenser Model Accepts Kit ZWWP48D

ZIS48NY Non-Dispenser Model Accepts Kit ZWWP48

### Black.

ZISB48DY Black Dispenser Model Accepts Kit ZWBP48D

ZIS48NY Non-Dispenser Model Accepts Kit ZWBP48

### Stainless steel.

ZISW48DY White Dispenser Model Accepts Kit ZWSP48D

ZISB48DY Black Dispenser Model Accepts Kit ZWSP48D

ZIS48NY Non-Dispenser Model Accepts Kit ZWSP48



- ZISW42DY** 42" Built-In Refrigerator with White Dispenser
- ZISB42DY** 42" Built-In Refrigerator with Black Dispenser
- ZIS42NY** 42" Built-In Refrigerator without Dispenser

**Accessory panels.** All 42" refrigerators require door and grille panels. These 1/4" panel kits are available for installation in standard trim:

**White.**

- ZISW42DY White Dispenser Model Accepts Kit ZWWP42D
- ZIS42NY Non-Dispenser Model Accepts Kit ZWWP42

**Black.**

- ZISB42DY Black Dispenser Model Accepts Kit ZWBP42D
- ZIS42NY Non-Dispenser Model Accepts Kit ZWBP42

**Stainless Steel.**

- ZISW42DY White Dispenser Model Accepts Kit ZWSP42D
- ZISB42DY Black Dispenser Model Accepts Kit ZWSP42D
- ZIS42NY Non-Dispenser Model Accepts Kit ZWSP42



- ZISW36DY** 36" Built-In Refrigerator with White Dispenser
- ZISB36DY** 36" Built-In Refrigerator with Black Dispenser
- ZIS36NY** 36" Built-In Refrigerator without Dispenser

**Accessory panels.** All 36" refrigerators require door and grille panels. These 1/4" panel kits are available for installation in standard trim:

**White.**

- ZISW36DY White Dispenser Model Accepts Kit ZWWP36D
- ZIS36NY Non-Dispenser Model Accepts Kit ZWWP36

**Black.**

- ZISB36DY Black Dispenser Model Accepts Kit ZWBP36D
- ZIS36NY Non-Dispenser Model Accepts Kit ZWBP36

**Stainless steel.**

- ZISW36DY White Dispenser Model Accepts Kit ZWSP36D
- ZISB36DY Black Dispenser Model Accepts Kit ZWSP36D
- ZIS36NY Non-Dispenser Model Accepts Kit ZWSP36



## Built-In Refrigerator Custom Panel Guide

Most Monogram® built-in refrigerators are equipped to accept 1/4" accessory panels (shown on the previous page) or 1/4" custom panels which are available through your cabinet manufacturer. For a trimless appearance, the doors and grille may be fitted with 3/4" decorative panels, available through your cabinet manufacturer in a variety of materials and finishes. The standard full-length handles provide a contemporary style, but you may elect to further enhance the exterior with the addition of custom handles. An extremely custom look for dispenser model refrigerators can be achieved with a one-piece freezer panel when using the custom dispenser collar trim. Decorative side panels are required wherever the sides of the refrigerator are exposed.

### Customization kits:

**ZKH1.** Provides for the installation of custom handles of your choice on 1/4" accessory or custom panels (handles not included).

**ZG2.** The factory set height for GE Monogram built-in refrigerators is 84". Grille panels are adjustable to accommodate installation heights from 83" to 84-1/2". This kit provides side trim pieces for 83", 83-1/2" and 84-1/2" installation heights.

**ZKT36, ZKT42, or ZKT48.** Enables the installation of 3/4" custom door and grille panels, in combination with the standard full-length refrigerator handles, to create a trimless appearance.

**ZKHT1.** Provides for the installation of custom handles of your choice onto 3/4" custom panels (handles not included). This kit must be used in combination with ZKT36, ZKT42, or ZKT48 3/4" custom panel kits.

**ZWCD1.** Custom dispenser collar kit for 36" and 42" models creates a trimless appearance around the dispenser.

**ZWCD2.** Custom dispenser collar kit for 48" models creates a trimless appearance around the dispenser.

**ZWT1.** White toekick kit provides for the installation of a 48", 42" and 36" side-by-side toekick, or a 36" bottom-mount toekick.



### Tubular Handle Kits:

**ZKHSS1** Stainless Steel Tubular Handle Kit for 1/4" custom panels.

**ZKHTSS1** Stainless Steel Tubular Handle Kit to be used with ZKT36, ZKT42, or ZKT48 3/4" custom panel kits.

Call GE Quick Specs, 800.432.3729, to request dimensions and specifications for Monogram refrigerators and have the data faxed directly to the fax number you provide. For technical assistance and answers to your questions about GE Monogram refrigerators, call the GE Answer Center® 800.626.2000.

**Additional features and installation information.** See pages 122 and 123.



### Non-dispenser model

1/4" custom panels.  
No trim kit required.

Standard handles.  
No trim kit required.



### Non-dispenser model

3/4" custom trimless door and grille panels.  
Requires ZKT36, ZKT42 or ZKT48 trim kit.

Standard handles.  
No trim kit required.



### Non-dispenser model

1/4" custom panels.  
No trim kit required.

Custom handles.  
Requires ZKH1 handle kit.



### Non-dispenser model

3/4" custom trimless door and grille panels.  
Requires ZKT36, ZKT42 or ZKT48 trim kit.

Custom handles.  
Requires ZKHT1 handle kit.

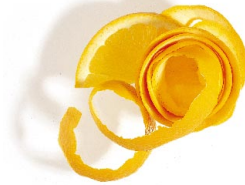

**Dispenser model**

1/4" custom panels.  
No trim kit required.  
  
Standard handles.  
No trim kit required.



**Dispenser model**

1/4" custom panels.  
No trim kit required.  
  
Standard handles.  
No trim kit required.  
  
Custom dispenser collar.  
Requires ZWCD1 (36" and 42" models) or ZWCD2 (48" models) collar kit.



**Dispenser model**

3/4" custom trimless door and grille panels.  
Requires ZKT36, ZKT42 or ZKT48 trim kit.  
  
Standard handles.  
No trim kit required.



**Dispenser model**

3/4" custom trimless door and grille panels.  
Requires ZKT36, ZKT42 or ZKT48 trim kit.  
  
Standard handles.  
No trim kit required.  
  
Custom dispenser collar.  
Requires ZWCD1 (36" and 42" models) or ZWCD2 (48" models) collar kit.



**Dispenser model**

1/4" custom panels.  
No trim kit required.  
  
Custom handles.  
Requires ZKH1 handle kit.



**Dispenser model**

1/4" custom panels.  
No trim kit required.  
  
Custom handles.  
Requires ZKH1 handle kit.  
  
Custom dispenser collar.  
Requires ZWCD1 (36" and 42" models) or ZWCD2 (48" models) collar kit.



**Dispenser model**

3/4" custom trimless door and grille panels.  
Requires ZKT36, ZKT42 or ZKT48 trim kit.  
  
Custom handles.  
Requires ZKHT1 handle kit.



**Dispenser model**

3/4" custom trimless door and grille panels.  
Requires ZKT36, ZKT42 or ZKT48 trim kit.  
  
Custom handles.  
Requires ZKHT1 handle kit.  
  
Custom dispenser collar.  
Requires ZWCD1 (36" and 42" models) or ZWCD2 (48" models) collar kit.

## Built-In Stainless Steel Refrigerators

These Monogram® built-in refrigerators come wrapped in stainless steel with tubular handles. They offer an intelligently designed storage system. Glass shelves and modular bins can be quickly repositioned to suit ever-changing storage needs.

**Independent controls.** Fresh-food and freezer sections have individual temperature controls, which allow for precise calibration.

**Chilled water and ice.** Monogram offers built-in refrigerator models with a dispenser neatly encircled by stainless steel. With a light press of the dispenser's cushioned pad, chilled water, ice cubes, or crushed ice are delivered through the freezer door.

**Convenient access.** Automatic door-holds keep each door motionless at 90 degrees and 130 degrees, for easy food storage and removal.

### Fresh food compartment:

**Abundant storage.** Four adjustable shelves and five adjustable door bins offer extensive storage flexibility. One shelf slides back to make room for tall containers; another drops down for additional space when needed.

**Wine holder.** The wine caddy suspends securely from a shelf edge to cradle a single bottle.

**Vegetable, snack, and dairy compartments.** Two full-width vegetable pans with individual humidity controls, as well as a sealed snack pan, glide open with ease. Special storage space on the door keeps dairy items fresh and accessible.

### Freezer compartment:

**Abundant storage.** The freezer offers flexible space with adjustable bins on the door and shelves in the interior that can be arranged to suit storage requirements. Two utility baskets extend fully, providing easy access to bulk storage.

**Icemaker.** The freezer is outfitted with an automatic icemaker that shuts off when the ice bin is full. The large capacity bin is easily removed for access to bulk ice.

**Adjustable Grille Panel Kit.** The factory set height for Monogram built-in refrigerators is 84". Grille panels are adjustable to accommodate installation heights from 83" to 84-1/2". To insure proper airflow to the compressor, this kit provides grille panels for 83", 83-1/2" and 84-1/2" installation heights.

ZGSSW48 Adjustable Grille Panel Kit for 48" refrigerator.

ZGSSW42 Adjustable Grille Panel Kit for 42" refrigerator.

**Additional features and installation information.** See pages 122 and 123.



**ZISS48DASS** 48" Built-In Stainless Steel Refrigerator with Dispenser



**ZISS48NASS** 48" Built-In Stainless Steel Refrigerator without Dispenser



**ZISS42DASS** 42" Built-In Stainless Steel Refrigerator with Dispenser



**ZISS42NASS** 42" Built-In Stainless Steel Refrigerator without Dispenser

## Free-Standing Refrigerator

The lustrous stainless steel finish of the Monogram® free-standing refrigerator presents a professional appearance and reflects the quality and performance of its internal systems. The interior of the GE Monogram free-standing refrigerator offers a smartly planned 27 cubic-foot capacity.

**Independent controls.** Fresh-food and freezer sections have separate controls to allow proper temperature calibration for each compartment.

**Chilled water and ice.** A light press of the dispenser's cushioned pad delivers chilled water, ice cubes, or crushed ice through the freezer door. And the water and ice dispensed is filtered "Water By Culligan," so it's cleaner and better tasting.

### **Fresh food compartment:**

**Abundant storage.** Three adjustable glass shelves have raised edges to help contain spills and simplify cleaning. Four adjustable door bins, large enough for gallon-size containers, offer extensive storage flexibility.

**Wine holder.** The wine caddy suspends securely from a shelf edge to cradle a single bottle.

**Vegetable, snack, and dairy compartments.** A special compartment in the door keeps dairy products fresh and accessible. A vegetable crisper and meat pan offer adjustable humidity control.

### **Freezer compartment:**

**Abundant storage.** The freezer offers five shelves in the door and three adjustable shelves in the interior that can be arranged to suit changing needs. A slide-out transparent storage bin offers a full view of contents.

**Icemaker.** The freezer is outfitted with an automatic icemaker that shuts off when the ice bin is full. The large capacity bin is easily removed for access to bulk ice.

**Additional features and installation information.** See pages 122 and 123.



**ZFSB27DASS** Stainless Steel Free-Standing Refrigerator



## Bottom-Mount Refrigerators

The Monogram® bottom-mount refrigerators offer eye-level access to fresh foods. A dual-rear lighting system provides full view of all contents. Both wire tiers of the 6.7 cubic foot freezer with full-extension slides roll out within easy reach for restacking and arranging frozen items.

**Independent controls.** Fresh food and freezer sections have separate controls to allow proper temperature calibration for each compartment.

**Convenient access.** Automatic door hold keeps fresh food door motionless from 45 degrees to 130 degrees making food storage and removal easy.

### Fresh food compartment:

**Abundant storage.** Four adjustable shelves have raised edges to help contain spills and simplify cleaning. Four adjustable door bins, two large enough for gallon-size containers, offer extensive storage flexibility.

**Wine holder.** The wine caddy suspends securely from a shelf edge to cradle a single bottle.

**Vegetable, snack and dairy compartments.** Two full-width vegetable pans with individual humidity controls, as well as, two sealed snack pans, glide open with ease. Special storage space on the door keeps dairy items fresh and accessible.

### Freezer compartment:

**Abundant storage.** The freezer offers two tiers for arranging or re-stocking frozen foods. It also has full-extension slides so you can pull it out for easy access.

**Icemaker.** The freezer is outfitted with an automatic icemaker that shuts off when the ice bin is full. The large capacity bin is easily removed for access to bulk ice.

**Additional features and installation information.** See pages 124 and 125.



**ZICS36NARH** 36" Built-In Stainless Steel Bottom-Mount Refrigerator (*hinged on right side*)

**ZICS36NALH** 36" Built-In Stainless Steel Bottom-Mount Refrigerator (*hinged on left side, shown above*)

**Stainless steel exterior.** These models come wrapped in stainless steel with full-length tubular handles.

### Customization kits:

**ZGCSS36LH or ZGCSS36RH.** The factory set height for GE Monogram bottom-mount refrigerators is 84". This Kit provides two grille panels for the 83-1/2" and 84-1/2" installation heights on models ZICS36NALH and ZICS36NARH.

**ZFC1.** Provides for side-by-side installation of two bottom-mount refrigerators. Includes a trim strip to cover gap between the two refrigerators as seen on pages 38 and 39.





**ZIC36NARH** 36" Built-In Bottom-Mount Refrigerator  
(right-handed opening)

**ZIC36NALH** 36" Built-In Bottom-Mount Refrigerator  
(left-handed opening)

**Accessory panels.** These models require 1/4" door and grill panels. Three 1/4" panel kits are available white, black or stainless steel. For a trimless appearance, the door and grill may be fitted with a 3/4" decorative panel.

ZWWC36 White Lexan® Panel Kit

ZWBC36 Black Lexan® Panel Kit

ZWSC36 Stainless Steel Panel Kit



**Customization kits:**

**ZGC2.** The factory set height for Monogram bottom-mount refrigerators is 84". This kit provides 1/4" grille panel frame side pieces for 83-1/2" and 84-1/2" on models ZIC36NARH and ZIC36NALH.

**ZKHC1.** Provides for the installation of custom handles of your choice on 1/4" accessory or custom panels.

**ZKTC36LH or ZKTC36RH.** Enables the installation of 3/4" custom door panels to create a trimless appearance. Replacement handle is supplied with this kit.

**ZKHTC1.** Provides for the installation of custom handles of your choice onto 3/4" custom panels (handles not included). This kit must be used in combination with ZKTC36LH or ZKTC36RH 3/4" custom panel kits.

**ZFC1.** Provides for side-by-side installation of two bottom-mount refrigerators. Includes a trim strip to cover gap between the two refrigerators as seen on pages 38 and 39.

**ZWT1.** White toekick kit provides for the installation of a 48", 42" and 36" side-by-side toekick, or a 36" bottom-mount toekick.

**Tubular Handle Kits:**

**ZKHCSS1.** Stainless Steel Tubular Handle Kit for 1/4" accessory or custom panels.

**ZKHTCSS1.** Stainless Steel Tubular Handle Kit for 3/4" custom panels requires ZKTC36LH or ZKTC36RH trim kit.

## Beverage Center and Wine Chiller

Monogram® brings you two ways to make entertaining easier. The beverage center allows chilling of standing containers such as bottles and cans and up to 14 reclining bottles of wine. The wine chiller holds up to 50 resting bottles of your vintage labels. Both of these appliances are vented at the front toekick, allowing built-in under-counter installation. The black or white finished case provides an alternative for free-standing use.

**Flexibility in design.** The free-standing wine chiller and beverage center may be built into cabinetry. The door swing is reversible to accommodate various placements.

**Proper display.** The clear glass door affords a full view of bottles and cans and interior lighting is controlled by an independent external switch. If not turned on manually, the light automatically illuminates your wine and beverage collection upon opening the door.

**Smooth utility.** Full-width racks slide out smoothly to simplify selection and storage.

**Additional features and installation information.** See pages 126 and 127.

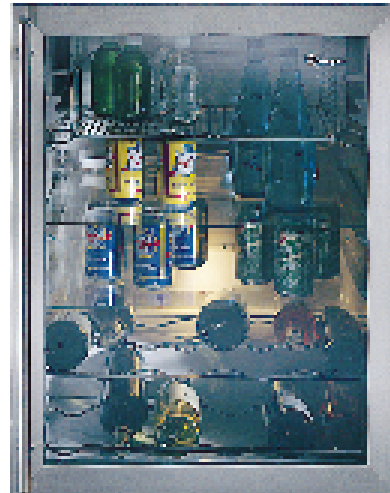

**ZDB24ABB** Beverage Center with Black Case and Toekick

**ZDB24AWW** Beverage Center with White Case and Toekick

**Temperature Control.** The unique shelving configuration creates a range of temperatures to achieve just the right level of cooling for different beverages. In the top portion, temperatures range from 33° to 39° Fahrenheit for keeping beverages cold. The temperature spans from 39° to 45° Fahrenheit in the middle area. The bottom section, designed especially for chilling wines, features open wire racks for a temperature range of 44° to 52° Fahrenheit.

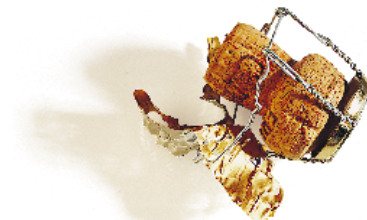

## Icemakers



**ZDW24ABB** Wine Chiller with Black Case and Toekick

**ZDW24AWW** Wine Chiller with White Case and Toekick

**Temperature Control.** Adjustable thermostat can be set between low 40s and mid 60s Fahrenheit to hold wine at the appropriate temperature level.



**ZDIS15CSS** Stainless Steel Automatic Icemaker

**ZDI15CWW** White Automatic Icemaker

**ZDI15CBB** Black Automatic Icemaker

**Decorative options.** The 15" icemaker door accepts 3/4" custom panels (using ZIP75WW white kit or ZIP75BB black kit) to coordinate or contrast with cabinetry.

**Commercial quality ice.** Utilizing a process known as fractional freezing, water moves over a cold plate until it freezes. The remaining water is then discarded, resulting in clear, commercial quality ice.

**High production, large capacity.** A valuable asset for party hosts and catering staffs. The icemaker produces up to 50 lbs. of clear ice per day and automatically shuts off when the 25-lb. capacity bin is full.

**Ease of use.** The door swing is reversible and provides easy access to the ice bin and an interior light comes on automatically when the door is opened.

**Additional features and installation information.** See pages 126 and 127.

## Dishwashers

The full-length sweep of simple lines, without the usual access panel at the bottom to interrupt the view makes the design of these dishwashers architecturally stunning. On one model, you'll notice the satisfying textural feel of the handsome brushed stainless steel facade every time you open the door. The full-wrap look extends around the molded edges for trimless styling. Other models accept custom panels to match cabinetry.

**Stainless steel interior.** The 18:10 grade surgical steel interior maintains its lustrous appearance throughout years of use. Tub seams are welded to guard against leaking and rusting.

**Five-level wash system.** This system sprays water in five different directions, covering virtually every part of each dish, eliminating the need for pre-rinsing, soaking and scrubbing.

**Continuously clean water.** All wash water passes through a multiple-filtration system, which continuously cleans the water and prevents food soils from re-entering the wash system. Multiple-filtration minimizes the need to pre-rinse dishes.

**Efficient dual-pump design.** The primary pump circulates fresh incoming water while the secondary drain pump eliminates any soil residue from the previous wash cycle. This dual-pump action enhances wash performance while efficiently reducing water fills and wash time.

**Hot washing and condensate drying.** A thermostatically-controlled, 1200-watt heating element raises water temperature to ensure thorough cleaning. The hot water rinse and condensate drying system minimize the spotting of dishes.

**Nylon-coated racks and tines.** Durable nylon coating cushions dishes and glassware during thorough, gentle wash action.

**Two-position upper rack.** The upper rack glides out easily and can be repositioned depending on the appropriate height for the dishload. In addition to four cup shelves, there are prongs especially shaped to hold fragile stemware.

**Flexible lower rack.** Adjustable, fold-down tines allow the lower rack to be arranged to accept various sizes of dishes, pots and pans. Rack tines are "dog-legged" shaped to securely hold your heavier stoneware plates and deep-dish servers.

**Extra-quiet operation.** Heavy-duty insulation, designed to dampen the sounds of the wash action, is bonded to the exterior of the stainless steel tub. A thick layer of sound-absorbing material lines the door and access panels. The induction motor, mounted on rubber, runs quietly and more efficiently than the standard motors used in most domestic dishwashers.

**Additional features and installation information.** See pages 128 and 129. Not all features are available on all models.



**ZBD5900DSS** Stainless Steel Dishwasher

**Stainless steel exterior.** Brushed stainless steel gives an elegant, high-tech impression that sets off any decor.

**Sparkling results.** A multiplicity of choices allows you to select up to 19 cycle/options combinations for various types of dishes and cookware.

**Pre-planned dishwashing.** The delay-start option offers the convenience of scheduling dishwashing to begin up to six hours later.

**Control features.** The child-lock setting prevents "unauthorized" turning on of your washer. An auto-memory mode recalls your preferred cycle/option combination for washing.

**Interior light.** An inside light is unique to American dishwashers.

**Sanitization.** This special cycle option delivers hot water at 171° Fahrenheit for exceptionally clean results.

**NSF Certification.** Meets NSF protocol for sanitization and cleaning performance of household spray-type dishwashers (1997).



**ZBD5700DBB** Black Dishwasher

**ZBD5700DWW** White Dishwasher

**Custom panels.** These models accept 1/4" custom panels using the ZPF25W or ZPF25B trim kit. The ZPF75W and ZPF75B trim kit provides for the installation of 3/4" custom panels.

**Sparkling results.** A multiplicity of choices allows you to select up to 19 cycle/options combinations for various types of dishes and cookware.

**Pre-planned dishwashing.** The delay-start option offers the convenience of scheduling dishwashing to begin up to six hours later.

**Control features.** The child-lock setting prevents "unauthorized" turning on of your washer. An auto-memory mode recalls your preferred cycle/option combination for washing.

**Interior light.** An inside light is unique to American dishwashers.

**Sanitization.** This special cycle option delivers hot water at 171° Fahrenheit for exceptionally clean results.

**NSF Certification.** Meets NSF protocol for sanitization and cleaning performance of household spray-type dishwashers (1997).

**ZBD5600DWW** White Dishwasher

**ZBD5600DBB** Black Dishwasher

**Custom panels.** These models accept 1/4" custom panels using the ZPF25W or ZPF25B trim kit. The ZPF75W and ZPF75B trim kit provides for the installation of 3/4" custom panels.

**Sparkling results.** Multiple cycles allow you to select up to 17 cycle/option combinations. Three-level wash system, multiple filters, and dual pump work together to keep the circulating water clean as it washes every surface of every dish.

**ZBD4200DWW** White Dishwasher

**ZBD4200DBB** Black Dishwasher

**ZBD4500DSS** Stainless Steel Dishwasher

**Custom panels.** These models accept stainless steel panels using GPF400S trim kit or 3/4" custom panels using the GPF475 trim kit. These kits include GPF100 heavy duty spring kit for custom panels weighting 4 to 8 pounds. The GPF425W or GPF425B trim kit provides for the installation of 1/4" custom panels.

**SaniWash.** This cycle reduces 99.999% bacteria found on dishes, silverware—even baby bottles, and is NSF Certified.

**Three Wash Arms.** No rinsing, soaking or scrubbing. This three-arm wash system delivers a powerful spray to every spot on every dish.

**100% Triple Filtration.** All water is passed through a unique three-filter system to remove food particles.

**Technological ingenuity.** Water volume and temperature are adjusted to suit heavy to lightly soiled dishloads. An electronic sensor monitors the loads' soil level and adjusts the temperature, time and amount of water needed for an efficient clean wash.

**Quiet operation.** Carefully engineered mechanics and two types of insulation reduce noise and eliminate a need for vents at the toekick level. The active vent on the escutcheon further reduces sound by closing during the wash cycle.

**Tough interior.** PermaTuf® tub and door liners are durable and engineered to remain stain-free.

## Compactors

Monogram® compactors do a big job in a small space, a perfect companion appliance for cosmopolitan kitchens.

**12" width.** The slim design conserves space and permits the compactor to be easily integrated into kitchen cabinetry.

**Decorative options.** The standard black/white drawer panel is reversible. The drawer accepts a stainless steel panel kit 24-M117 and can be customized with a 1/4" panel or adapted to accept a custom 3/4" panel without requiring a trim kit.

**Adjustable toekick.** During installation, the compactor base can be moved backward or forward to align with the toekick depths of adjacent cabinetry.

**Powerful action.** Up to 5,000 pounds of compressive force reduces trash volume by 75%.

**Drawer-style design.** The slide-out compactor drawer is convenient and easy to use.

**Safety lock and key.** A removable key locks the compactor, starts operation, and assures that the drawer remains locked during use.

**Additional features and installation information.** See pages 126 and 127.

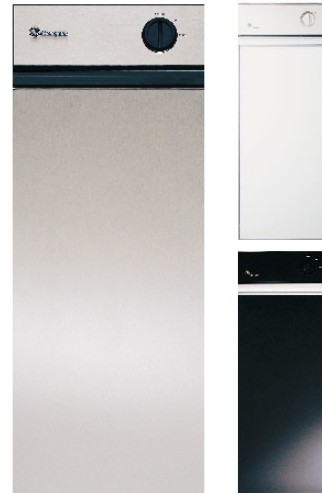

**ZCG3500DSS** Stainless Steel Compactor

**ZCG3300VWW** White Compactor

**ZCG3100VBB** Black Compactor

## GE Monogram Planning Guide

Creating the ultimate kitchen is a process that begins in the imagination, progresses to plans on paper, and culminates in the realization of your vision. As your imagination circles down to the pragmatic execution of your concepts, the information that follows can serve as a guide. The dimensions, specifications, and installation data provided here are meant to assist you in selecting the Monogram™ products from GE that best suit your plans and preferences. You may call GE QuickSpecs, 800.432.3729, to request dimensions and specifications on any Monogram appliance, and have the data transmitted, within minutes, to the fax number you provide. For technical assistance and answers to your questions about GE Monogram appliances, call the GE Answer Center® 800.626.2000 any time.



## 48" Professional Ranges

ZDP48N4GWSS, ZDP48L4GWSS, ZDP48N6RWSS, ZDP48L6RWSS, ZDP48N6DWSS and ZDP48L6DWSS 48" Professional Ranges

Note: Reference pub. no. 49-8814-1, GE Monogram Professional Range Installation Instructions, for complete details.

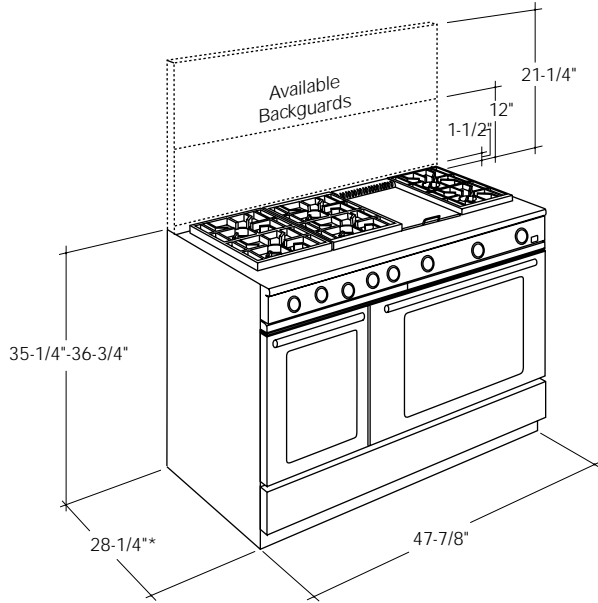

\* Depth including handle is 31-1/2"

Available backguards (must be ordered with range).  
 ZX1B48WSS 1-1/2" island backguard\*  
 ZX12B48WSS 12" backguard  
 ZX22B48ASS 22" backguard with warming shelf  
 \*Must maintain a 12" clearance between the rear of the cooking surface and a combustible vertical surface.

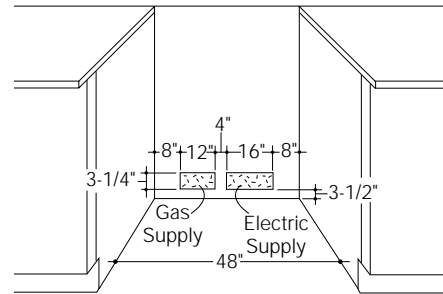

## 48" Professional Ranges

		ZDP48N4GWSS ZDP48L4GWSS	ZDP48N6RWSS ZDP48L6RWSS	ZDP48N6DWSS ZDP48L6DWSS
<b>DESCRIPTION</b>		48" Range with 4 Burners, Grill and Griddle	48" Range with 6 Burners and Grill	48" Range with 6 Burners and Griddle
<b>OVEN PERFORMANCE</b>				
Capacity ( <i>cu. ft.</i> )	Main Oven	4.3	4.3	4.3
	Companion Oven	2.0	2.0	2.0
Interior	Main Oven	Convection	Convection	Convection
	Companion Oven	Thermal	Thermal	Thermal
Bake Element	Main Oven	10-Pass	10-Pass	10-Pass
	Companion Oven	4-Pass	4-Pass	4-Pass
Broil Element	Main Oven	8-Pass	8-Pass	8-Pass
	Companion Oven	6-Pass	6-Pass	6-Pass
<b>COOKTOP PERFORMANCE</b>				
15,000/500 BTU Dual-Ring Gas Burners		4	6	6
Electronic Ignition w/ Auto. Reignition		•	•	•
Cast-Iron, Porcelainized Burner Grates		•	•	•
Thermostatically-Controlled Griddle		18,000 BTU's		18,000 BTU's
18,000 BTU Grill		•	•	
<b>OVEN CONVENIENCE</b>				
Interior	Main Oven	Self-Clean	Self-Clean	Self-Clean
	Companion Oven	Standard Clean	Standard Clean	Standard Clean
5-Hour Cleaning Time		Main Oven	Main Oven	Main Oven
Rack Positions	Main Oven	3	3	3
	Companion Oven	3	3	3
Removable Racks	Main Oven	3	3	3
	Companion Oven	2	2	2
Broil Pans	Main Oven	2	2	2
	Companion Oven	2	2	2
Interior Oven Lights	Main Oven	2	2	2
	Companion Oven	1	1	1
<b>COOKTOP CONVENIENCE</b>				
Two-Piece Reversible Grill Grate		•	•	
Stainless-Steel, Slide-Out Drip Trays		2	2	2
Removable Drip Tray Liners		(2) Beneath Grill and Griddle	(1) Beneath Grill	(1) Beneath Griddle
Optional Wok Accessory		Order ZXWK22Y	Order ZXWK22Y	Order ZXWK22Y
<b>APPEARANCE</b>				
Color Appearance		Stainless Steel	Stainless Steel	Stainless Steel
Stainless-Steel Grill/Griddle Covers		2	1	1
<b>GENERAL FEATURES</b>				
Fuel Configuration	Oven	Electric	Electric	Electric
	Cooktop	Natural Gas LP Gas	Natural Gas LP Gas	Natural Gas LP Gas
Interior Dimensions ( <i>WxHxD in inches</i> )	Main Oven	27-3/4 x 14-1/4 x 18-1/2	27-3/4 x 14-1/4 x 18-1/2	27-3/4 x 14-1/4 x 18-1/2
	Companion Oven	12 x 14-1/4 x 20-1/2	12 x 14-1/4 x 20-1/2	12 x 14-1/4 x 20-1/2
Overall Dimensions ( <i>WxHxD in inches</i> )		47-7/8 x 35-1/4 - 36-3/4 x 28-1/4	47-7/8 x 35-1/4 - 36-3/4 x 28-1/4	47-7/8 x 35-1/4 - 36-3/4 x 28-1/4
Bake/Broil Wattage	Main Oven	5000/4000	5000/4000	5000/4000
	Companion Oven	2800/3600	2800/3600	2800/3600
120/240 Volt, 4-Wire		•	•	•
Amps @ 240VAC		48.3	48.3	48.3
Approx. Shipping Weight ( <i>lbs.</i> )		602	595	600
Full One-Year Warranty*		•	•	•
Additional 4-Year Burner Warranty*		Limited	Limited	Limited

\*See written warranty for details.



## 36" and 30" Professional Ranges

ZDP36N6WSS, ZDP36L6WSS, ZDP36N4RWSS, ZDP36L4RWSS, ZDP36N4DWSS and ZDP36L4DWSS 36" Professional Ranges

Note: Reference pub. no. 49-8814-1, GE Monogram Professional Range Installation Instructions, for complete details.

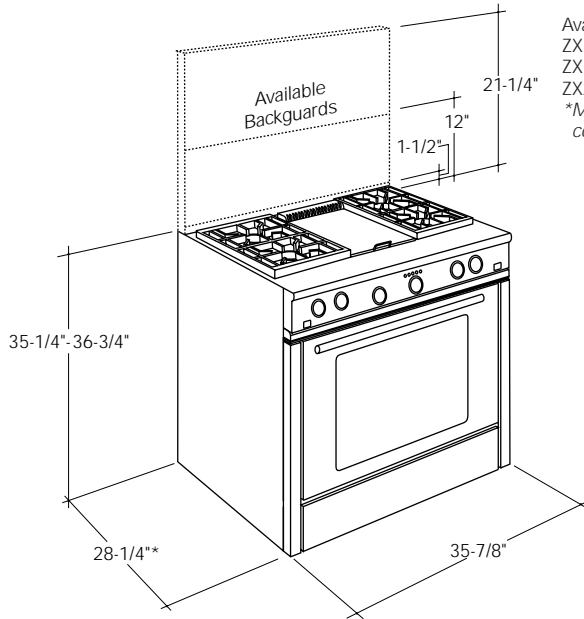

Available backguards (must be ordered with range).  
 ZX1B36WSS 1-1/2" island backguard\*  
 ZX12B36WSS 12" backguard  
 ZX22B36ASS 22" backguard with warming shelf  
 \*Must maintain a 12" clearance between the rear of the cooking surface and a combustible vertical surface.

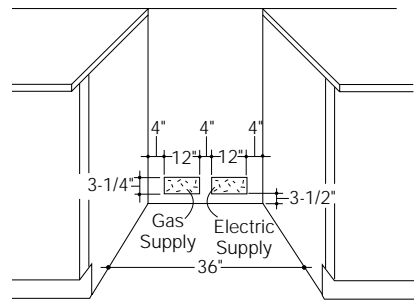

\* Depth including handle is 31-1/2"

ZDP30N4YSS and ZDP30LAYSS 30" Professional Ranges

Note: Reference pub. no. 49-8814 for ZDP30N/LAYSS GE Monogram Professional Range Installation Instructions, for complete details.

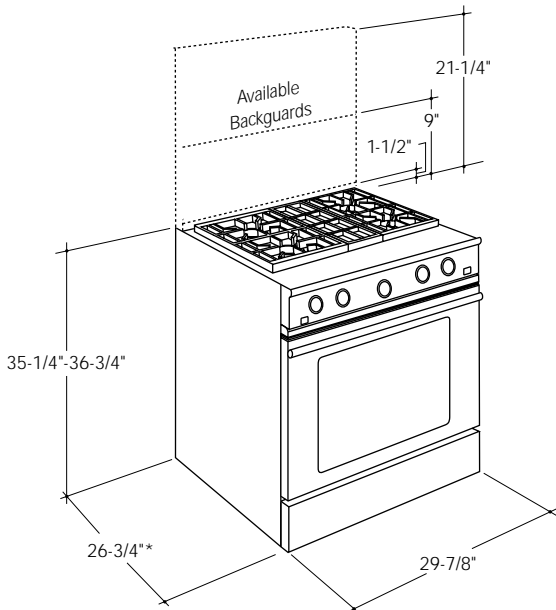

Available backguards (must be ordered with range).  
 ZX1B30YSS 1-1/2" island backguard\*  
 ZX12B30YSS 9" backguard  
 ZX22B30ASS 22" backguard with warming shelf  
 \*Must maintain a 12" clearance between the rear of the cooking surface and a combustible vertical surface.

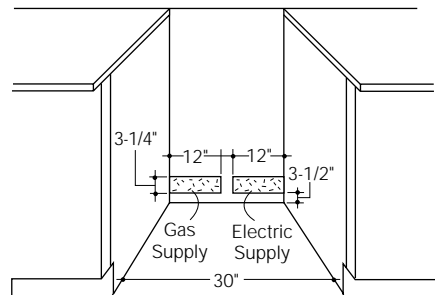

\*Depth including handle is 29-1/4".

## 36" and 30" Professional Ranges

	ZDP36N6WSS ZDP36L6WSS	ZDP36N4RWSS ZDP36L4RWSS	ZDP36N4DWSS ZDP36L4DWSS	ZDP30N4YSS ZDP30L4YSS
<b>DESCRIPTION</b>				
	36" Range with 6 Burners	36" Range with 4 Burners and Grill	36" Range with 4 Burners and Griddle	30" Range with 4 Burners
<b>OVEN PERFORMANCE</b>				
Capacity (cu. ft.)	4.3	4.3	4.3	4.0
Interior	Convection	Convection	Convection	Convection
Bake Element	10-Pass	10-Pass	10-Pass	6-Pass
Broil Element	8-Pass	8-Pass	8-Pass	8-Pass
<b>COOKTOP PERFORMANCE</b>				
15,000/500 BTU Dual-Ring Gas Burners	6	4	4	4
Electronic Ignition w/Auto. Reignition	•	•	•	•
Cast-Iron, Porcelainized Burner Grates	•	•	•	•
Thermostatically-Controlled Griddle			18,000 BTU's	
18,000 BTU Grill		•		
<b>OVEN CONVENIENCE</b>				
Interior Oven	Self-Clean	Self-Clean	Self-Clean	Self-Clean
5-Hour Cleaning Time	•	•	•	•
Rack Positions	3	3	3	3
Removable Racks	3	3	3	3
Broil Pans	•	•	•	•
Interior Oven Lights	2	2	2	•
<b>COOKTOP CONVENIENCE</b>				
Two-Piece Reversible Grill Grate		•		
Stainless-Steel, Slide-Out Drip Trays	1	1	1	1
Removable Drip Tray Liners		(1) Beneath Grill	(1) Beneath Griddle	
Optional Wok Accessory	Order ZXWK22Y	Order ZXWK22Y	Order ZXWK22Y	Order ZXWK22Y
<b>APPEARANCE</b>				
Color Appearance	Stainless Steel	Stainless Steel	Stainless Steel	Stainless Steel
Stainless-Steel Grill/Griddle Covers		1	1	
<b>GENERAL FEATURES</b>				
Fuel Configuration	Oven Electric	Electric	Electric	Electric
	Cooktop Natural Gas LP Gas	Natural Gas LP Gas	Natural Gas LP Gas	Natural Gas LP Gas
Interior Dimensions (WxHxD in inches)	27-3/4 x 14-1/4 x 18-1/2	27-3/4 x 14-1/4 x 18-1/2	27-3/4 x 14-1/4 x 18-1/2	24 x 14 x 20-3/8
Overall Dimensions (WxHxD in inches)	35-7/8 x 35-1/4 - 36-3/4 x 28-1/4	35-7/8 x 35-1/4 - 36-3/4 x 28-1/4	35-7/8 x 35-1/4 - 36-3/4 x 28-1/4	29-7/8 x 35-1/4 ± 36-3/4 x 26-3/4
Bake/Broil Wattage	5000/4000	5000/4000	5000/4000	3700/4000
120/240 Volt, 4-Wire	•	•	•	•
Amps @ 240VAC	29.2	29.2	29.2	19.9
Approx. Shipping Weight (lbs.)	415	415	415	396
Full One-Year Warranty*	•	•	•	•
Additional 4-Year Burner Warranty*	Limited	Limited	Limited	Limited

\*See written warranty for details.



## Professional Cooktops

ZGU48N4GWSS, ZGU48L4GWSS, ZGU48N6RWSS, ZGU48L6RWSS, ZGU48N6DWSS and ZGU48L6DWSS 48" Professional Cooktops

Note: Reference pub. no. 49-8812-1, GE Monogram Professional Cooktop Installation Instructions, for complete details.

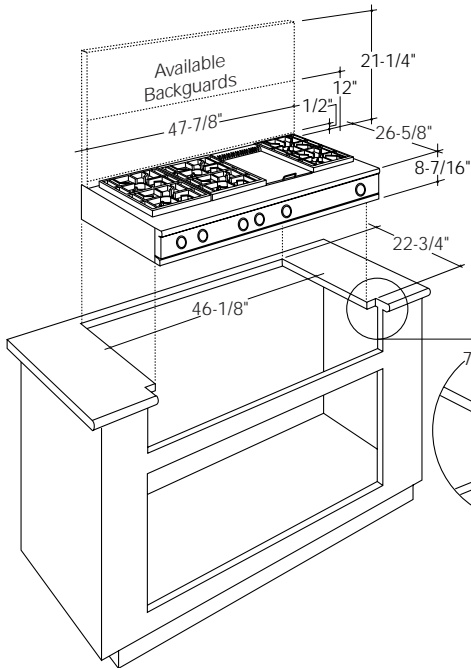

Available backguards (must be ordered with cooktop).  
 ZXC1B48BSS island trim\*  
 ZXC12B48WSS 12" backguard  
 ZXC22B48ASS 22" backguard with warming shelf  
 \*Must maintain a 12" clearance between the rear of the cooking surface and a combustible vertical surface.

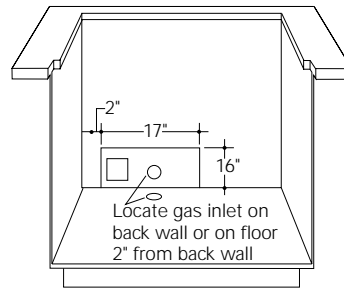

ZGU36N6YSS, ZGU36L6YSS, ZGU36N4RYSS, ZGU36L4RYSS, ZGU36N4DYSS and ZGU36L4DYSS 36" Professional Cooktops

Note: Reference pub. no. 49-8812-1, GE Monogram Professional Cooktop Installation Instructions, for complete details.

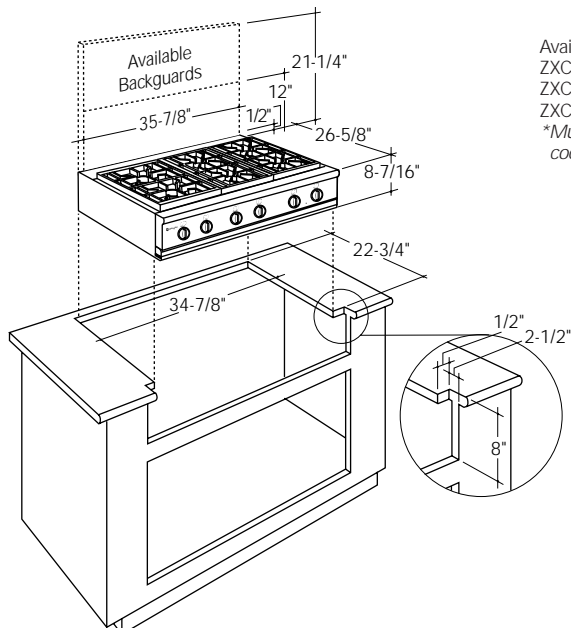

Available backguards (must be ordered with cooktop).  
 ZXC1B36BSS island trim\*  
 ZXC12B36YSS 12" backguard  
 ZXC22B36ASS 22" backguard with warming shelf  
 \*Must maintain a 12" clearance between the rear of the cooking surface and a combustible vertical surface.

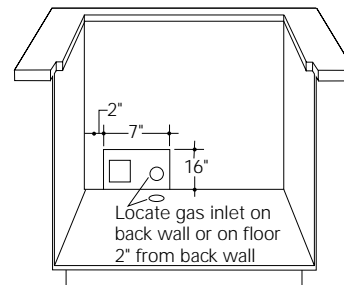

## Professional Cooktops

	ZGU48N4GWSS ZGU48L4GWSS	ZGU48N6RWSS ZGU48L6RWSS	ZGU48N6DWSS ZGU48L6DWSS	ZGU36N6YSS ZGU36L6YSS	ZGU36N4RYSS ZGU36L4RYSS	ZGU36N4DYSS ZGU36L4DYSS
<b>DESCRIPTION</b>	48" Cooktop with 4 Burners, Grill and Griddle	48" Cooktop with 6 Burners and Grill	48" Cooktop with 6 Burners and Griddle	36" Cooktop with 6 Burners	36" Cooktop with 4 Burners and Grill	36" Cooktop with 4 Burners and Griddle
<b>PERFORMANCE</b>						
15,000/500 BTU Dual-Ring Gas Burners	4	6	6	6	4	4
Electronic Ignition w/ Auto. Reignition	•	•	•	•	•	•
Cast-Iron, Porcelainized Burner Grates	•	•	•	•	•	•
Thermostatically-Controlled Griddle	18,000 BTU's		18,000 BTU's			18,000 BTU's
18,000 BTU Grill	•	•			•	
<b>CONVENIENCE</b>						
Two-Piece Reversible Grill Grate	•	•			•	
Stainless-Steel, Slide-Out Drip Trays	2	2	2	1	1	1
Removable Drip Tray Liner	(2) Beneath Grill and Griddle	(1) Beneath Grill	(1) Beneath Griddle		(1) Beneath Grill	(1) Beneath Griddle
Optional Wok Accessory	Order ZXWK22Y	Order ZXWK22Y	Order ZXWK22Y	Order ZXWK22Y	Order ZXWK22Y	Order ZXWK22Y
<b>APPEARANCE</b>						
Color Appearance	Stainless Steel	Stainless Steel	Stainless Steel	Stainless Steel	Stainless Steel	Stainless Steel
Stainless-Steel Grill/Griddle Cover	2	1	1		1	1
<b>GENERAL FEATURES</b>						
Fuel Configuration	Natural Gas LP Gas	Natural Gas LP Gas	Natural Gas LP Gas	Natural Gas LP Gas	Natural Gas LP Gas	Natural Gas LP Gas
Overall Dimensions (WxHxD in inches)	47-7/8 x 8-7/16 x 26-5/8	47-7/8 x 8-7/16 x 26-5/8	47-7/8 x 8-7/16 x 26-5/8	35-7/8 x 8-7/16 x 26-5/8	35-7/8 x 8-7/16 x 26-5/8	35-7/8 x 8-7/16 x 26-5/8
120 Volt	•	•	•	•	•	•
Amps @ 120VAC	6.6	3.3	3.3	1.0	3.3	3.3
Approx. Shipping Weight (lbs.)	324	324	324	228	228	228
Full One-Year Warranty*	•	•	•	•	•	•
Additional 4-Year Burner Warranty*	Limited	Limited	Limited	Limited	Limited	Limited

\*See written warranty for details.



## Professional Hoods

ZV891YSS, ZV890YSS, ZV881WSS and ZV880WSS 48" Hoods, ZV681YSS, ZV680YSS, ZV671WSS and ZV670WSS 36" Hoods, ZV371YSS and ZV370YSS 30" Hoods

Note: Reference pub. no. 49-8816-1, GE Monogram Professional Hood Installation Instructions, for complete details.

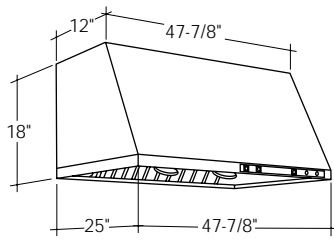

ZV891YSS, ZV890YSS\*

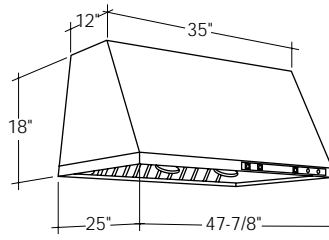

ZV881WSS, ZV880WSS\*

\*Blower outlet: 4-1/2" x 18-1/2"  
Required duct size: 10" round  
3-1/4" x 24" rectangular

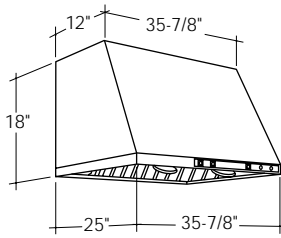

ZV681YSS, ZV680YSS\*\*

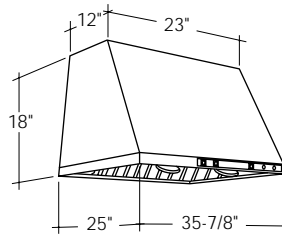

ZV671WSS, ZV670WSS\*\*

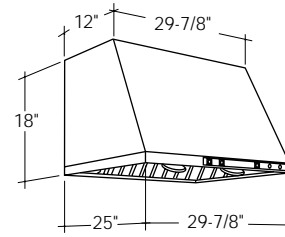

ZV371YSS, ZV370YSS\*\*

\*\*Blower outlet: 7" round  
Required duct size: 7" to 10" round  
3-1/4" x 12" to 3-1/4" x 24" rectangular

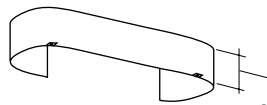

Optional 6" or 12"  
Duct Cover

Style A-Oval  
Duct Covers for models:  
ZV881WSS, ZV880WSS,  
ZV671WSS and ZV670WSS.

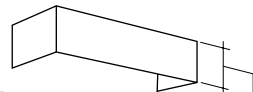

Optional 6" or 12"  
Duct Cover

Style B- Square  
Duct Covers for models:  
ZV891YSS, ZV890YSS,  
ZV681YSS, ZV680YSS,  
ZV371YSS and ZV370YSS.

### Optional Accessory Duct Covers

Style	Models	6" Duct Covers		12" Duct Covers	
A-Oval	ZV881WSS, ZV880WSS	ZX6DC48WSS	6"H x 27-3/8"W x 10-1/4"D	ZX12DC48WSS	12"H x 27-3/8"W x 10-1/4"D
A-Oval	ZV671WSS, ZV670WSS	ZX6DC36WSS	6"H x 22-1/2"W x 9-3/16"D	ZX12DC36WSS	12"H x 22-1/2"W x 9-3/16"D
B-Square	ZV891YSS, ZV890YSS	ZX6DC49YSS	6"H x 47-7/8"W x 12"D	ZX12DC49YSS	12"H x 47-7/8"W x 12"D
B-Square	ZV681YSS, ZV680YSS	ZX6DC38YSS	6"H x 35-7/8"W x 12"D	ZX12DC38YSS	12"H x 35-7/8"W x 12"D
B-Square	ZV371YSS, ZV370YSS	ZX6DC30YSS	6"H x 29-7/8"W x 12"D	ZX12DC30YSS	12"H x 29-7/8"W x 12"D

## Professional Hoods

	ZV891YSS	ZV890YSS	ZV681YSS	ZV680YSS	ZV371YSS	ZV370YSS
Straight-Sided	ZV891YSS	ZV890YSS	ZV681YSS	ZV680YSS	ZV371YSS	ZV370YSS
Tapered-Sided	ZV881WSS	ZV880WSS	ZV671WSS	ZV670WSS		
<b>PERFORMANCE</b>						
Variable Speed Fan Control	•	•	•	•	•	•
Vertical Exhaust Blower Rating (CFM)	1200	1200	600	600	600	600
<b>CONVENIENCE</b>						
Halogen Lamps	2	2	2	2	1	1
Infrared Warming Lamps	2		1		1	
Removable Stainless Steel Filters	2	2	1	1	1	1
<b>APPEARANCE</b>						
Color Appearance	Stainless Steel	Stainless Steel	Stainless Steel	Stainless Steel	Stainless Steel	Stainless Steel
<b>DUCT OPTIONS</b>						
3-1/4" x 24" rectangular duct	•	•	Option	Option	Option	Option
10" round duct	Option	Option	Option	Option	Option	Option
7" round duct			•	•	•	•
3-1/4" x 12" rectangular duct			Option	Option	Option	Option
<b>GENERAL FEATURES</b>						
Overall Dimensions (WxD in inches)	47-7/8 x 18 x 25	47-7/8 x 18 x 25	35-7/8 x 18 x 25	35-7/8 x 18 x 25	29-7/8 x 18 x 25	29-7/8 x 18 x 25
Amps @ 120VAC	10.0	10.0	7.3	7.3	7.3	7.3
Approx. Shipping Weight (lbs.)	130	126	110	108	110	110
Full One-Year Warranty*	•	•	•	•	•	•

\*See written warranty for details.



# Electric Cooktops

## ZEU36WMRABG, ZEU365ABG and ZEU304ABG Digital Cooktops

Note: Reference pub. no. 49-8900 for ZEU36WMRABG and ZEU365ABG, 49-8899 for ZEU304ABG, GE Monogram Digital Cooktop Installation Instructions, for complete details.

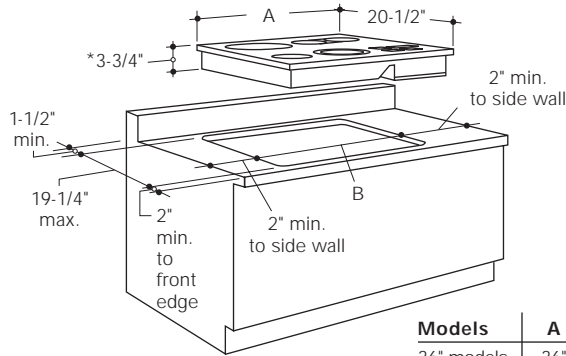

Models	A	B
36" models	36"	34-3/8"
30" models	30"	28-3/8"

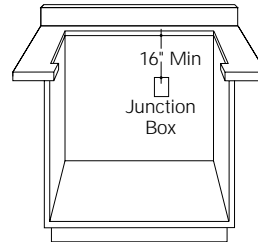

\*Requires 15" minimum clearance below the cooktop bottom to an internal enclosure to provide air circulation.

## ZEU676YSB Ribbon Cooktop

Note: Reference pub. no. 49-8789, GE Monogram Ceramic Cooktop Installation Instructions, for complete details.

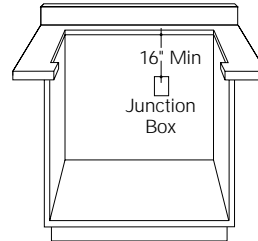
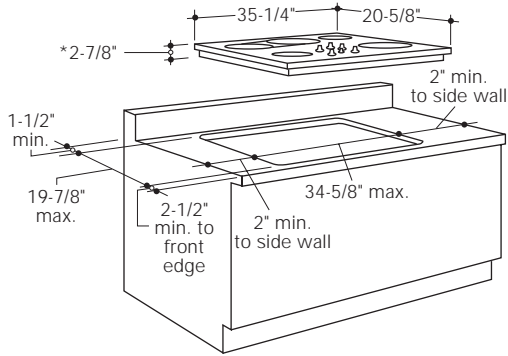

\*Requires 5" minimum clearance below the cooktop bottom to combustible materials.

## ZEU669AWW and ZEU668ABB Halogen and Ribbon Cooktops

Note: Reference pub. no. 49-8800, GE Monogram Halogen and Ribbon Cooktop Installation Instructions, for complete details.

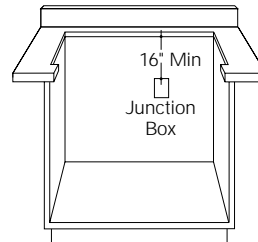
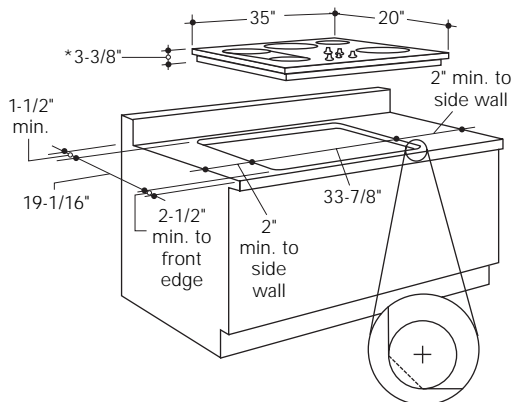

Note: Use template provided with installation instructions to obtain required 1/2" radius cut or angle cut in each corner.  
 \*Depth of the unit at conduit location (left rear): 4-3/4".  
 Requires 5" minimum clearance below the cooktop bottom to combustible materials.

## Electric Cooktops

	ZEU36WMRABG	ZEU365ABG	ZEU304ABG	ZEU676YSB	ZEU669AWW ZEU668ABB
<b>DESCRIPTION</b>	Ribbon Digital Electric Cooktop	Ribbon Digital Electric Cooktop	Ribbon Digital Electric Cooktop	Ribbon Electric Cooktop	Halogen and Ribbon Electric Cooktop
<b>PERFORMANCE</b>					
Cooking Areas	Six	Six	Five	Seven	Six
Warmer	1 Ribbon (250W)				1 Halogen 9" (2200W)
6-1/2" Heating Elements		1 Ribbon (1400W)	1 Ribbon (1400W)		1 Halogen 8" (1800W)
7" Heating Elements	2 Ribbon (1800W)	2 Ribbon (1800W)	2 Ribbon (1800W)	3 Ribbon (1800W)	2 Ribbon 7" (1500W)
Bridge Element	1 Ribbon (800W)	1 Ribbon (800W)	1 Ribbon (800W)	1 Ribbon (800W)	
6" Heating Elements	1 Ribbon (1200W)	1 Ribbon (1200W)		2 Ribbon (1200W)	1 Ribbon 6" (1200W)
Dual 6"/9" Heating Element	1 Ribbon (1000/2500W)	1 Ribbon (1000/2500W)	1 Ribbon (1000/2500W)	1 Ribbon 6"/8" (950/1900W)	
Ten-Step Rotary Control					Halogen Only
<b>CONVENIENCE</b>					
800W Ribbon Bridge Burner	Links 7" Elements	Links 7" Elements	Links 7" Elements	Links 7" Elements	Links 7" Elements
Hot Surface Indicator Lights	Five	Five	Four	Six	Five
<b>APPEARANCE</b>					
Patterned Tempered Glass Surface	•	•	•	•	•
Steel Surround or Mini-Frame				•	•
Frameless Design with Beveled Edge	•	•	•		
Color Appearance	Black	Black	Black	Black	White Black
<b>GENERAL FEATURES</b>					
Overall Dimensions (WxHxD in inches)	36 x 3-3/4 x 20-1/2	36 x 3-3/4 x 20-1/2	30 x 3-3/4 x 20-1/2	35-1/4 x 2-7/8 x 20-5/8	35 x 3-3/8 x 20
KW Rating @ 240VAC	8.3	9.5	8.1	10.5	9.4
@ 208VAC	6.2	7.1	6.1	7.9	7.1
Amps @ 240VAC	35	40	34	44	40
@ 208VAC	30	34	29	38	30
Approx. Shipping Weight (lbs.)	40	40	38	45	44
Full One-Year Warranty*	•	•	•	•	•
Additional 4-Year Limited Warranty*	Ribbon Elements and Glass Surface	Ribbon Elements and Glass Surface	Ribbon Elements and Glass Surface	Ribbon Elements and Glass Surface	Halogen and Ribbon Elements and Glass Surface

\*See written warranty for details.



# Gas Cooktops

## ZGU665WEX and ZGU665BEX Downdraft Gas Cooktops

Note: Reference pub. no. 49-8832, GE Monogram Downdraft Gas Cooktop Installation Instructions, for complete details.

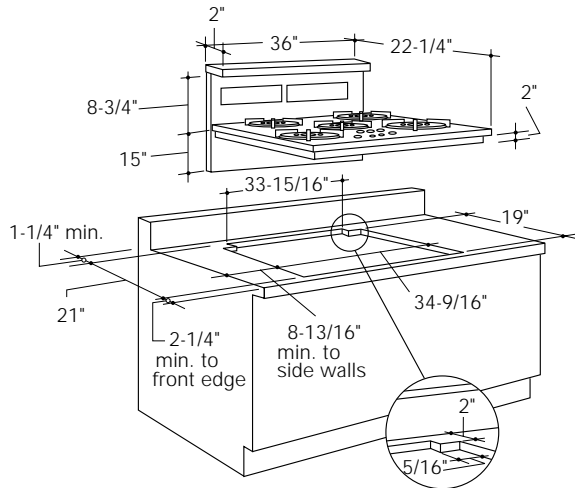

*Slab Installation: For peninsula or island installation and rear wall ducting, PVC duct should be used if installing under a poured concrete slab.*

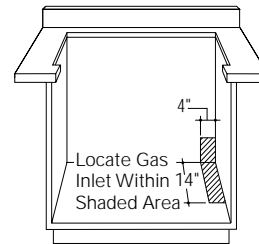

## ZGU651ES and ZGU650ES Updraft Gas Cooktops

Note: Reference pub. no. 49-8801, GE Monogram Updraft Gas Cooktop Installation Instructions, for complete details.

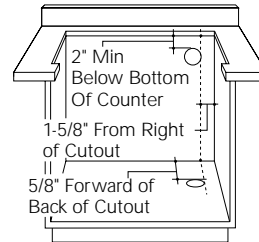
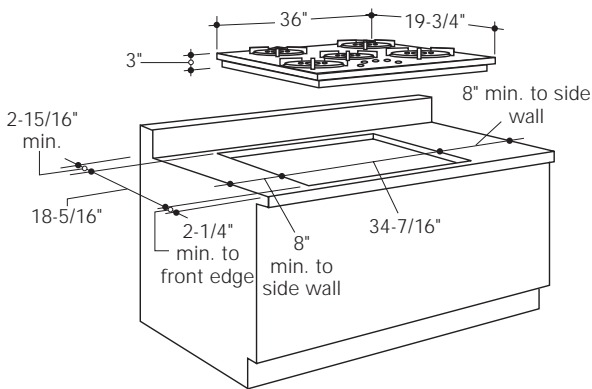

## Gas Cooktops

	ZGU665WEX ZGU665BEX	ZGU651ES ZGU650ES
<b>DESCRIPTION</b>	Downdraft Gas Cooktop	Updraft Gas Cooktop
<b>PERFORMANCE</b>		
Five Cooking Areas	•	•
Sealed Cooktop Burners	•	•
11,000 BTU Gas* Burners	2	2
6,500 BTU Gas* Burners	3	3
Automatic Reignition	•	•
Electronic Pilotless Ignition	•	•
Downdraft Venting System With Retractable Vent**	•	
Optional Blower Mount Capabilities	•	
<b>CONVENIENCE</b>		
Tempered Glass Surface	•	•
Cast-Iron, Porcelainized Burner Grates	•	•
Front-Mounted Controls	•	•
<b>APPEARANCE</b>		
Color Appearance	White Black	White Black
<b>GENERAL FEATURES</b>		
Overall Dimensions ( <i>WxD in inches</i> )	36 x 2 x 22-1/4	36 x 3 x 19-3/4
Burners ( <i>000's BTU's</i> )	(2) 11.0/8.5	(2) 11.0/8.5
Nat/LP Gas	(3) 6.5/4.5	(3) 6.5/4.5
Gas Cooktop Electrical Rating 120V, 60Hz	•	•
Amps @ 120VAC	5.0	5.0
Approx. Shipping Weight ( <i>lbs.</i> )	92	51
Full One-Year Warranty†	•	•

\*LP conversion orifices shipped with cooktops.

\*\*Important: Cooktop is shipped with snorkel downdraft vent assembly; JXBA55 Kit (motor and blower assembly) required. Must be ordered with cooktop.

JXBC55 optional outdoor cover accessory may be ordered for installation of motor and blower assembly on outside wall.

†See written warranty for details.



# Hood

## ZV750SY 36" Vent Hood

Note: Reference pub. no. 49-8775, GE Monogram 36" Vent Hood Installation Instructions, for complete details.

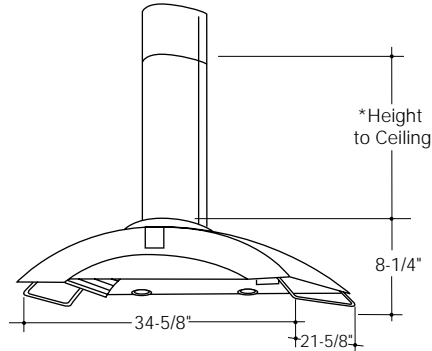

\*26-1/4" for 8 ft. ceiling  
 38-1/4" for 9 ft. ceiling  
 38-1/4" to 50-1/4" for 9 ft. to 10 ft. ceiling  
 using optional accessory ZX10SY Duct Cover

Blower outlet: 6" round

# Telescopic Downdraft Vent

ZVB36SBSS, ZVB36WBWW, ZVB36BBBB, ZVB30SBSS, ZVB30WBWW, and ZVB30BBBB Telescopic downdraft systems

Note: Reference pub. no. 49-8938 for 36" and 30" Telescopic Downdraft Vent Installation Instructions, for complete details.

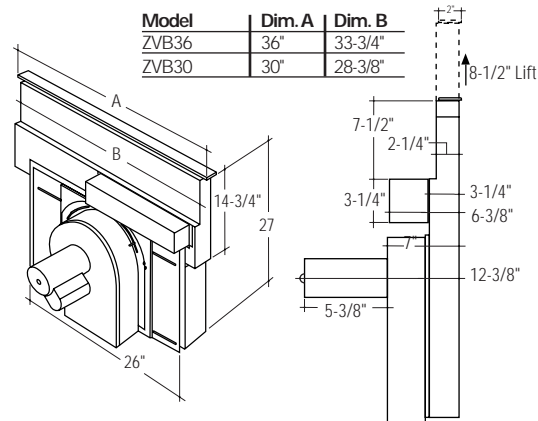

## Perimeter Installation with Standard Cabinet

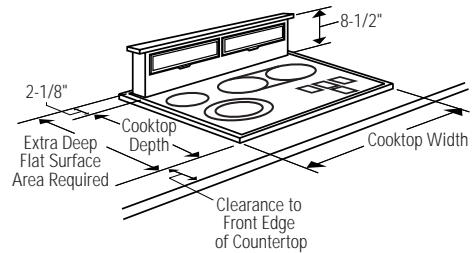

## Perimeter Installation with Sink Base Cabinet and Filler Panels

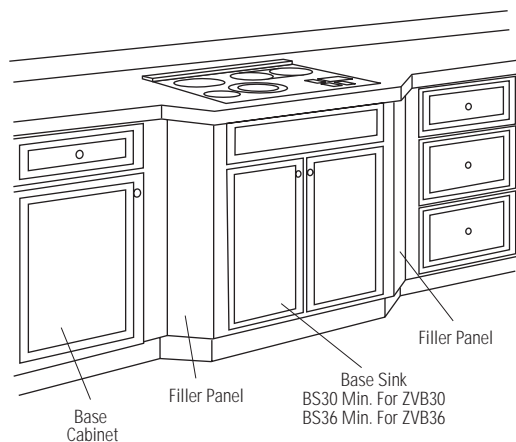

## Island Installation

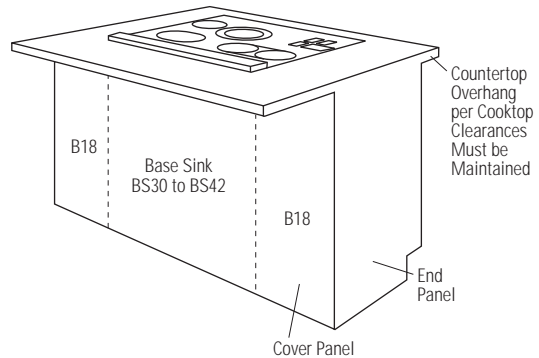

## Hood

ZV750SY	
Electronic Touchpad Controls	•
Vertical Exhaust Blower Rating (CFM)	360
Halogen Lamps	4
Removable Filters	3
Filter Cleaning Reminder	•
Color Appearance	Stainless Steel
6" Round Duct	•
Optional 10' Ceiling Extension Duct Cover	Order ZX10SY
Overall Dimensions (WxHxD in inches)	34-5/8 x 8-1/4 x 21-5/8
Amps @ 120VAC	2.5
Approx. Shipping Weight (lbs.)	81
Full One-Year Warranty*	•
<i>*See written warranty for details.</i>	

## Telescopic Downdraft Vent

	ZVB36SBSS ZVB36WBWW ZVB36BBBB	ZVB30SBSS ZVB30WBWW ZVB30BBBB
<b>DESCRIPTION</b>	36" Telescopic Downdraft System	30" Telescopic Downdraft System
<b>PERFORMANCE</b>		
Upfront Variable Speed Fan Control	•	•
Downdraft Exhaust (CFM)	500	500
Removable Grease Filters	•	•
3-1/4" x 10" Rectangular Duct	•	•
<b>CONVENIENCE</b>		
Indoor Remote Blower Kit	JXRB57	JXRB57
Outdoor Remote Blower Kit with Cover	JXBC57	JXBC57
<b>APPEARANCE</b>		
Top Trim Color	Stainless Steel White Black	Stainless Steel White Black
Stainless Steel Vent Body	•	•
<b>GENERAL FEATURES</b>		
Width (in inches)	36	30
KW Rating @ 120VAC	4.0	4.0
Amp Rating @ 120VAC	.5	.5
Approx. Shipping Weight (lbs.)	62	60
Full One-Year Warranty*	•	•
<i>*See written warranty for details.</i>		

**Important Installation Note:** The installation of these downdraft vents in combination with any Monogram Cooktop requires an extra deep countertop. The flat surface of the countertop must be deep enough, front to back, to accommodate the combined depth of the vent and cooktop together. Additional clearances required by UL from the cutout to the front edge of the countertop also vary by model and must be considered. Be sure to review the Downdraft Vent Installation Instructions (pub. no. 49-8938) carefully. These instructions provide exact cutout and countertop area requirements for the installation of the vent with each specific Monogram cooktop.



## Component Cooktops

### ZEW145V Halogen and Ribbon Component

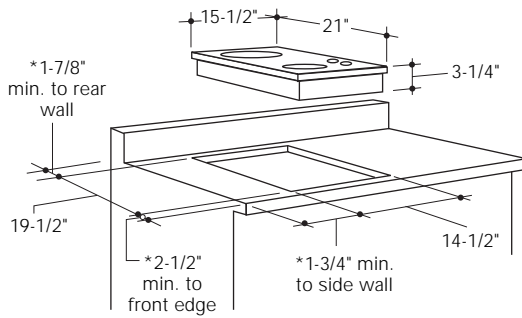

\* When installed, the following minimum clearances must be maintained: 2" from front of cooktop to front edge of countertop. 1" from back of cooktop to rear wall. 1" from side of cooktop to side wall.

### ZGW124EN and ZGW125EN Gas Components

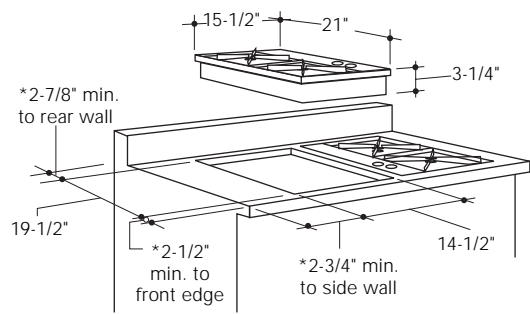

\* When installed, the following minimum clearances must be maintained: 2" from front of cooktop to front edge of countertop. 1" from back of cooktop to rear wall. 2" from side of cooktop to side wall.

### ZEW155N Updraft Grill Component

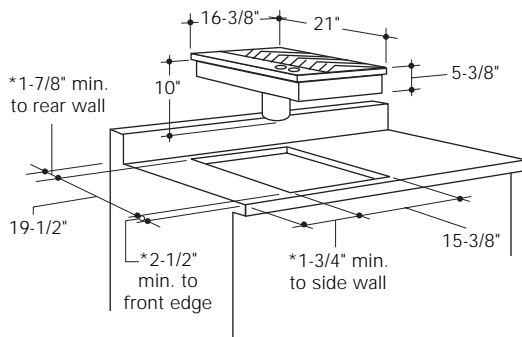

\* When installed, the following minimum clearances must be maintained: 2" from front of cooktop to front edge of countertop. 1" from back of cooktop to rear wall. 1" from side of cooktop to side wall.

### ZEW166Y Downdraft Grill Component

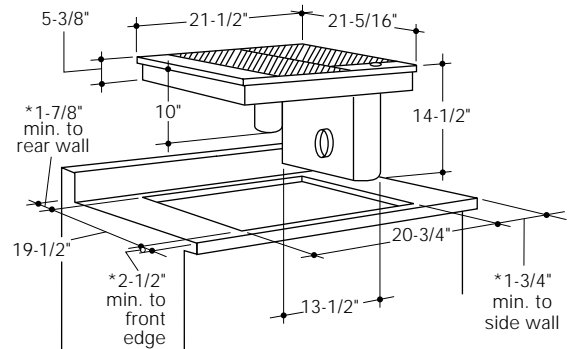

\* When installed, the following minimum clearances must be maintained: 2" from front of cooktop to front edge of countertop. 1" from back of cooktop to rear wall. 1" from side of cooktop to side wall.

### ZEW176Y Downdraft Vent Component

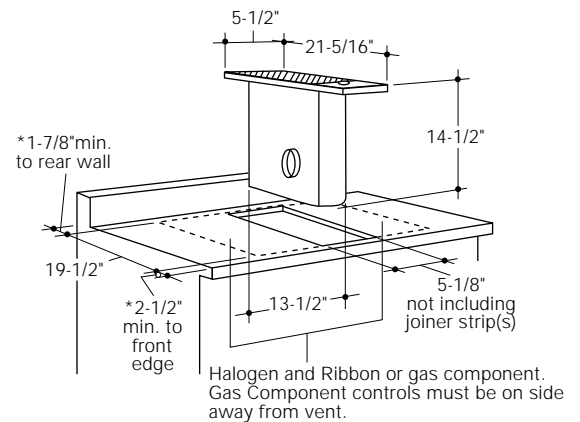

\* When installed, the following minimum clearances must be maintained: 2" from front of cooktop to front edge of countertop. 1" from back of cooktop to rear wall. 1" from side of cooktop to side wall.

## Component Cooktops

	ZEW145V	ZGW124EN	ZGW125EN	ZEW155N	ZEW166Y	ZEW176Y
<b>DESCRIPTION</b>	Halogen and Ribbon Component	Gas* Component with Right-Hand Controls	Gas* Component with Left-Hand Controls	Updraft Grill Component	Downdraft Grill Component	Downdraft Vent Component
<b>PERFORMANCE</b>						
8" Halogen Heating Element	1800W (240V) 1350W (208V)					
6" Ribbon Heating Element	1200W (240V) 900W (208V)					
Two Sealed Gas Burners		•	•			
10,500 BTU Large Gas* Burner		•	•			
6,000 BTU Small Gas* Burner		•	•			
Electronic Pilotless Ignition		•	•			
Automatic Reignition		•	•			
Downdraft Vent With Variable Speed Control					•	•
500 CFM Performance					•	•
1750W Heating Element				•		
2800W Heating Element					•	
Separate Controls for Each Half of Grill Heating Element				•	•	
<b>CONVENIENCE</b>						
Two Hot Surface Indicator Lights	•					
Ten-Step Rotary Control	Halogen Only					
Cast-Iron, Porcelainized Burner Grates		•	•			
Cast-Iron, Porcelainized Grill				•	•	•
Patterned Tempered Glass Cooktop	•					
<b>APPEARANCE</b>						
Component Surface Color	Black	Black	Black	Black	Black	Black
Stainless Steel Component Surround	•	•	•	•	•	•
Mix or Match Component Capability	•	•	•	•	•	•
Installation Horizontally or Vertically	•	•	•	•	•	•
<b>GENERAL FEATURES</b>						
Overall Dimensions (WxHxD in inches)	15-1/2 x 3-1/4 x 21	15-1/2 x 3-1/4 x 21	15-1/2 x 3-1/4 x 21	16-3/8 x 10 x 21	21-1/2 x 14-1/2 x 21-5/16	5-1/2 x 14-1/2 x 21-5/16
KW Rating @ 240VAC	3.0			1.8	3.3	N/A
@ 208VAC	2.3			N/A	N/A	N/A
Amps @ 240VAC	12.7			7.3	13.5	N/A
@ 208VAC	11.0			N/A	N/A	N/A
Cooktop Electrical Rating		120V, 60Hz, 5A	120V, 60Hz, 5A			120V, 60Hz
Approx. Shipping Weight (lbs.)	22	28	28	42	82	45
Full One-Year Warranty**	•	•	•	•	•	•
Additional 4-Year Warranty** on Halogen and Ribbon Elements and Glass Surface	Limited					

\*Natural gas only.  
Not convertible to liquid propane gas operation.  
\*\*See written warranty for details.



## Component Cooktop Electrical Information

### ZEW145V Halogen and Ribbon Component

Halogen and ribbon component shown with ZEW176Y downdraft vent. ZEW176Y (120 volts) must operate from separate junction box.

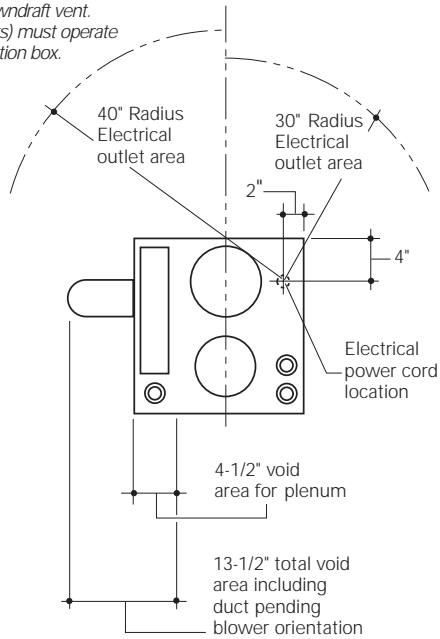

### ZGW124EN and ZGW125EN Gas Components

Left component shown. For right component, dimensions are opposite. Gas inlet pipe extends 1-1/4" from bottom of component. Gas component shown with ZEW176Y downdraft vent (120 volts), which can operate from the same junction box.

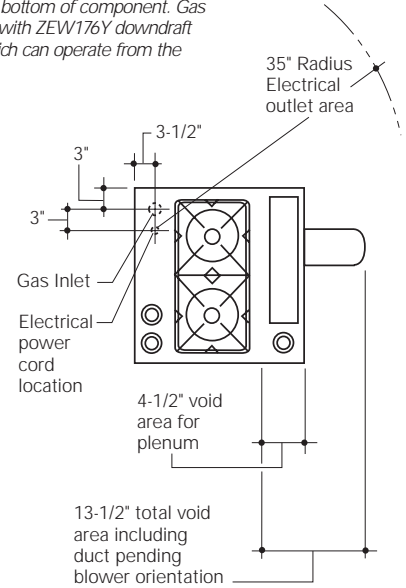

### ZEW155N Updraft Grill Component

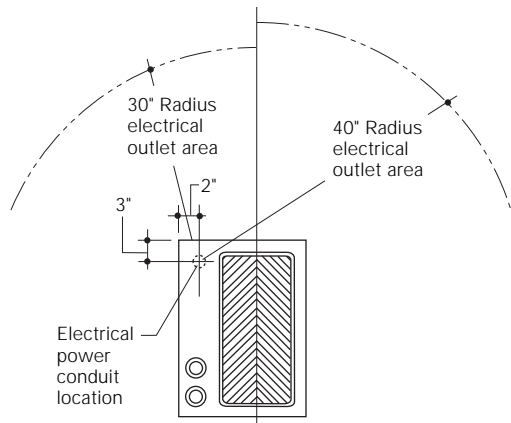



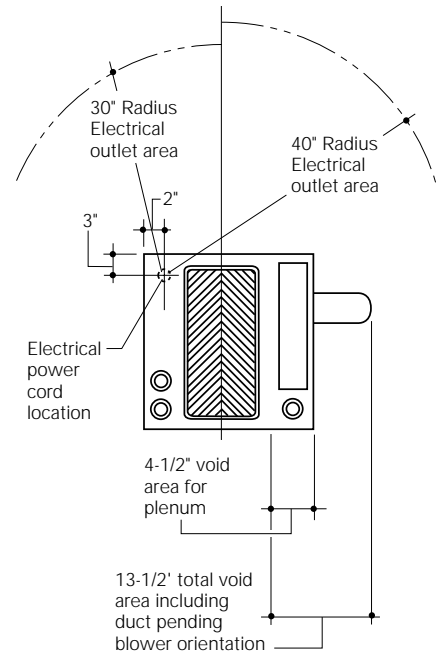











































### ZEW166Y Downdraft Grill Component





## Component Cooktop Cutout Options

**Multiple Component Cutout Options.** If multiple components will be attached together, determine cutout width from the following:

COMPONENT 1	COMPONENT 2	COMPONENT 3	COMPONENT 4	COMPONENT 5	CUTOUT WIDTH
 Halogen	 Halogen				29-3/4"
 RH Gas	 RH Gas				
 LH Gas	 LH Gas				
 Halogen	 Updraft Grill				30-5/8"
 RH Gas					
 LH Gas					
 Updraft Grill	 Updraft Grill				31-1/2"
 Downdraft Vent*	 Halogen				19-7/8"
	 RH Gas				
 Downdraft Grill*	 Halogen				35-1/2"
	 RH Gas				
 Halogen	 Downdraft Vent*	 Halogen			34-5/8"
 LH Gas		 RH Gas			
 Downdraft Grill*	 Halogen	 Halogen			50-3/4"
	 RH Gas	 RH Gas			
		 LH Gas			
 Halogen	 Downdraft Vent*	 Halogen	 Downdraft Vent*	 Halogen	54-3/4"
 Downdraft Vent*	 Halogen	 LH Gas	 Downdraft Vent*	 Halogen	55-1/4"
	 RH Gas			 RH Gas	
 Halogen	 Downdraft Vent*	 Downdraft Grill*	 Halogen		55-5/8"
 LH Gas			 RH Gas		

**Important Note:** Multiple component installations require joiner strips between components. Add 1/4" to total cutout for each downdraft vent-to-component connection; add 3/4" to total cutout for each component-to-component connection. See Component Cooktop System Installation Instructions pub.no. 49-8834 for specific installation requirements.



## European-Design Double and Single Ovens

	ZET857SBSS ZET857DBSB	ZET857BBBB ZET857WBWW	ZET837SBSS ZET837DBSB	ZET837BBBB ZET837WBWW
<b>DESCRIPTION</b>	30" Double Oven	30" Double Oven	30" Single Oven	30" Single Oven
<b>PERFORMANCE</b>				
Convection Oven(s)	Upper and Lower	Upper and Lower	•	•
Self-Cleaning Oven(s)	Upper and Lower	Upper and Lower	•	•
Convection Bake	•	•	•	•
Convection Roast	•	•	•	•
Convection Broil	•	•	•	•
Proof	•	•	•	•
Concealed Bake Element	•	•	•	•
3000W Variable Broil	•	•	•	•
Broil Element	12-Pass	12-Pass	12-Pass	12-Pass
Broil Pan	•	•	•	•
<b>CONVENIENCE</b>				
Self-Clean Delay Option	•	•	•	•
Self-Clean Automatic Door Lock	•	•	•	•
Preheat Light	•	•	•	•
Convection Roasting Rack	•	•	•	•
Convection Floor Rack	•	•	•	•
Electronic Clock and Kitchen Timer	•	•	•	•
Timed Cooking	•	•	•	•
<b>APPEARANCE</b>				
Frameless Glass Oven Door(s)	•	•	•	•
Color Appearance	Stainless Steel Stainless Steel on Black	Black White	Stainless Steel Stainless Steel on Black	Black White
Flush Appearance Installation	•	•	•	•
<b>GENERAL FEATURES</b>				
Oven Cabinet Width Required (in.)	30	30	30	30
Rack Positions (including floor rack)	5 (ea. oven)	5 (ea. oven)	5	5
Removable Racks				
Upper (including floor rack)	5	5	5	5
Lower (including floor rack)	5	5		
Interior Dimensions (WxHxD in inches)				
Upper	22-5/8 x 13-3/4 x 14-3/4	22-5/8 x 13-3/4 x 14-3/4	22-5/8 x 13-3/4 x 14-3/4	22-5/8 x 13-3/4 x 14-3/4
Lower	22-5/8 x 13-3/4 x 14-3/4	22-5/8 x 13-3/4 x 14-3/4		
Overall Dimensions (WxHxD in inches)	29-1/4 x 48 x 22	29-1/4 x 48 x 22	29-1/4 x 23-1/4 x 22	29-1/4 x 23-1/4 x 22
Convection Wattage	2500	2500	2500	2500
Broiler Wattage	3000	3000	3000	3000
Bake Wattage	2500	2500	2500	2500
KW Rating @ 240VAC	6.5	6.5	3.3	3.3
@ 208VAC	5.6	5.6	2.8	2.8
Amps @ 240VAC	27.1	27.1	13.8	13.8
@ 208VAC	26.9	26.9	13.5	13.5
Approximate Shipping Weight (lbs.)	300	300	140	140
Full One-Year Warranty*	•	•	•	•

\*See written warranty for details.



## American-Style Double and Single Ovens

### ZET757WA and ZET757BA 30" Double Ovens

Note: Reference pub. no. 49-8803, GE Monogram 30" Oven Installation Instructions, for complete details.

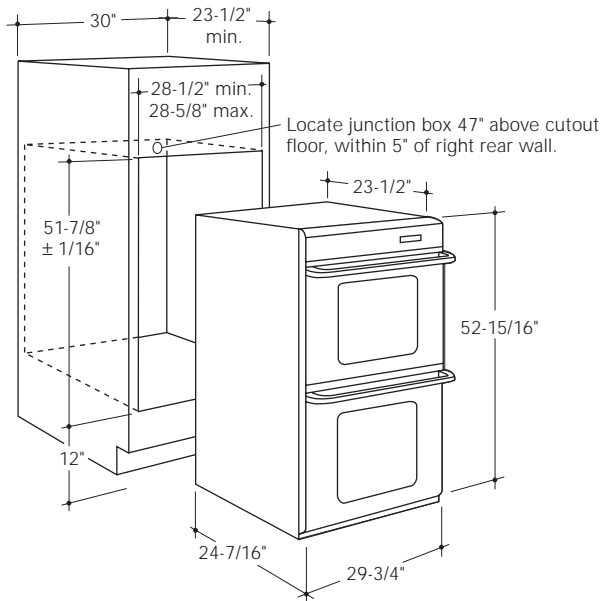

### ZEK757WA and ZEK757BA 27" Double Ovens

Note: Reference pub. no. 49-8804, GE Monogram 27" Oven Installation Instructions, for complete details.

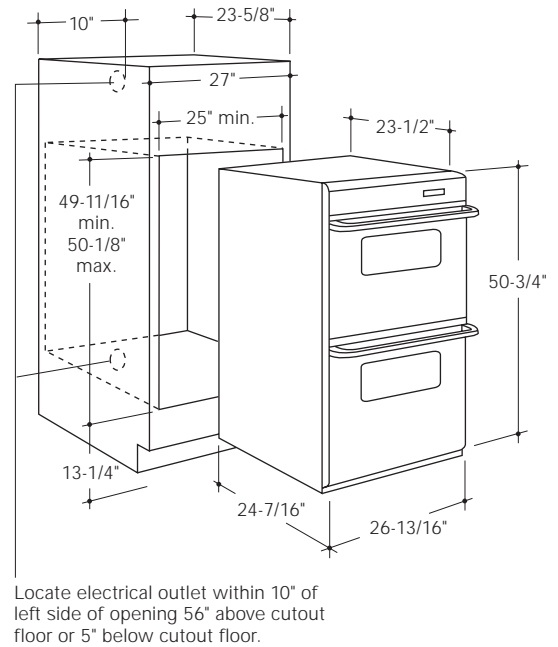

### ZET737WA and ZET737BA 30" Single Ovens

Note: Reference pub. no. 49-8803, GE Monogram 30" Oven Installation Instructions, for complete details.

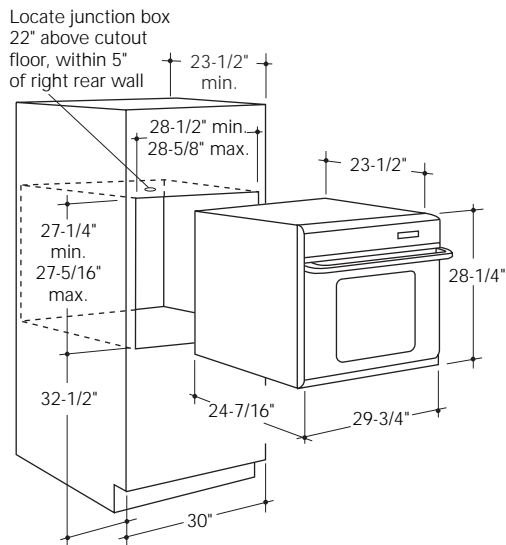

### ZEK737WA and ZEK737BA 27" Single Ovens

Note: Reference pub. no. 49-8804, GE Monogram 27" Oven Installation Instructions, for complete details.

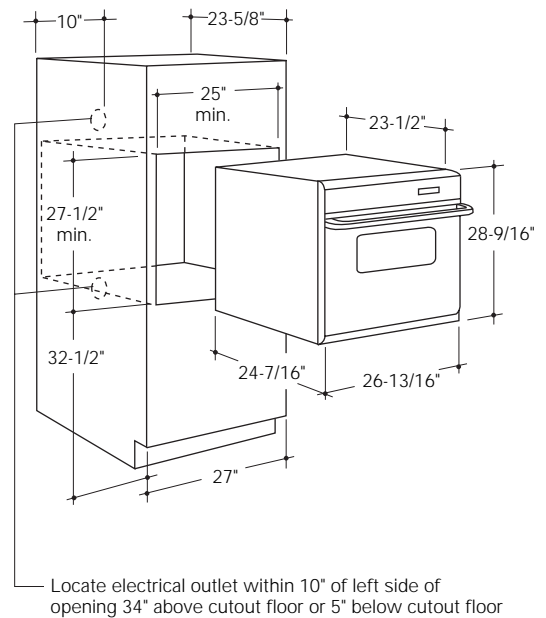



## American-Style Double and Sin

	ZET757WA ZET757BA	ZEK757WA ZEK757BA	ZET737WA ZET737BA	ZEK737WA ZEK737BA
<b>DESCRIPTION</b>	30" Double Oven	27" Double Oven	30" Single Oven	27" Single Oven
<b>PERFORMANCE</b>				
Convection Oven(s)	Upper and Lower	Upper and Lower	•	•
Self-Cleaning Oven(s)	Upper and Lower	Upper and Lower	•	•
Convection Bake	•	•	•	•
Convection Roast	•	•	•	•
4000W Variable Broil	•		•	
Broil Element	6-Pass	4-Pass	6-Pass	4-Pass
Roasting Rack	•	•	•	•
<b>CONVENIENCE</b>				
Self-Clean Delay Option	•	•	•	•
Independent Cook/Clean Controls	•	•	•	•
Convection Conversion	•	•	•	•
Automatic Meat Thermometer	Upper and Lower	Upper and Lower	•	•
Temperature Display	•	•	•	•
Start Pad	•	•	•	•
Delay Bake Option with Warm Mode	•	•	•	•
C° or F° Programmable	•	•	•	•
Audible Preheat Signal	•	•	•	•
Auto Oven Shut-Off With Override	•	•	•	•
Electronic Clock and Kitchen Timer	•	•	•	•
Control Lock Capability	•	•	•	•
24-Hour/12-Hour Time Display*	•	•	•	•
<b>APPEARANCE</b>				
Frameless Glass Oven Door(s)	•	•	•	•
Color Appearance	White Black	White Black	White Black	White Black
Flush Appearance Installation	•	•	•	•
Undercounter Installation			•	•
<b>GENERAL FEATURES</b>				
Oven Cabinet Width Required (in.)	30	27	30	27
Rack Positions	7 (ea. oven)	4 (ea. oven)	7	4
Removable Racks				
Upper	5	3		
Lower	5	3	5	3
Interior Dimensions (WxHxD in inches)				
Upper	24 x 17-3/8 x 15-3/4	19 x 15 x 16		
Lower	24 x 17-3/8 x 15-3/4	19 x 15 x 16	24 x 17-3/8 x 15-3/4	19 x 15 x 16
Overall Dimensions (WxHxD in inches)	29-3/4 x 52-15/16 x 24-7/16	26-13/16 x 50-3/4 x 24-7/16	29-3/4 x 28-1/4 x 24-7/16	26-13/16 x 28-9/16 x 24-7/16
Convection Wattage	2500	2500	2500	2500
Broiler Wattage	4000	3400	4000	3400
Bake Wattage	2585	2000	2585	2000
KW Rating @ 240VAC	8.0	6.8	4.0	3.4
@ 208VAC	6.0	5.1	3.0	2.6
Amps @ 240VAC	33.3	28.3	16.7	14.1
@ 208VAC	28.8	24.5	14.4	12.5
Approximate Shipping Weight (lbs.)	263	217	135	98
Full One-Year Warranty**	•	•	•	•

\*Permits Delay Bake Mode up to 24 hours in advance for those who observe the Sabbath.  
\*\*See written warranty for details.

# GE Monogram Warming Drawers

ZTD910SB, ZTD910WB and ZTD910BB 30" Warming Drawers. ZKD910SB, ZKD910WB and ZKD910BB 27" Warming Drawers.

Note: Reference pub. no. 49-8937 for 30" and 27" GE Monogram Warming Drawer Installation Instructions, for complete details.

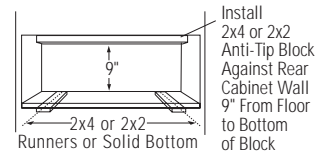
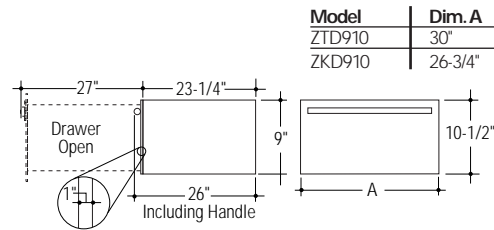

## Undercounter Installation

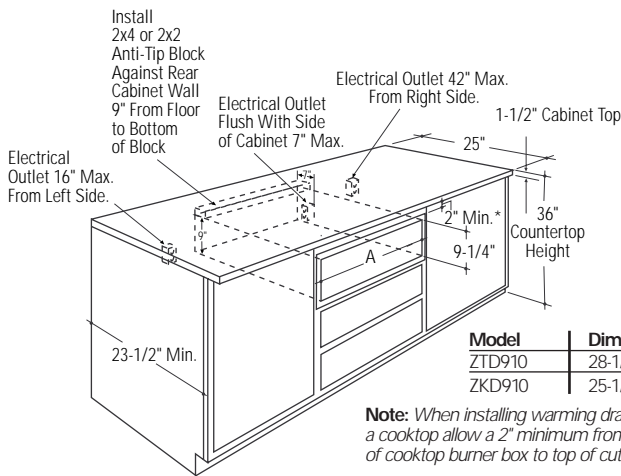

## Double Oven Installation

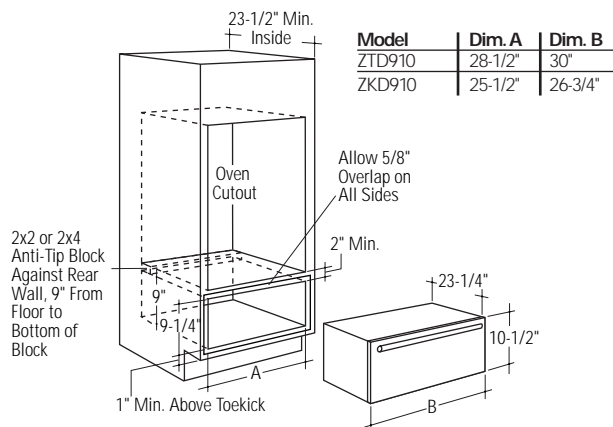

## Single Oven Installation

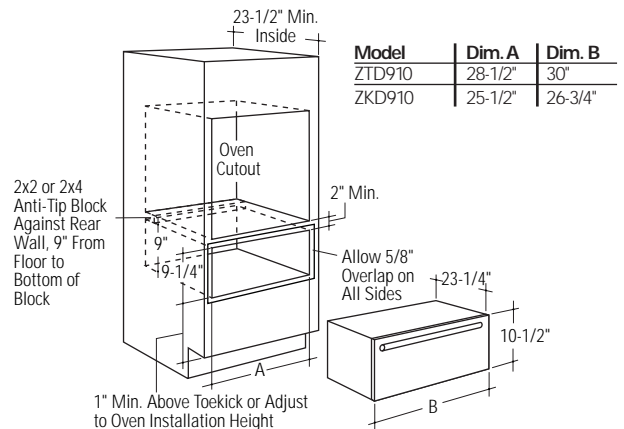

Note: Additional clearance between cutouts may be required. Check to be sure that oven supports above the Warming Drawer location does not obstruct the required interior 23-1/2" depth and 9-1/4" height.

## Warming Drawers

	ZTD910SB ZTD910WB ZTD910BB	ZKD910SB ZKD910WB ZKD910BB
<b>DESCRIPTION</b>		
	30" Warming Drawer	27" Warming Drawer
<b>FEATURES</b>		
Infinite Setting Temperature Control	75°-230°	75°-230°
Humidity Control	Crisp/Moist	Crisp/Moist
Hidden Control	•	•
Full-Extension Slides	•	•
On/Off Switch	•	•
"ON" Indicator Light	•	•
Half Rack	•	•
<b>APPEARANCE</b>		
Color Appearance	Stainless Steel White on White Black on Black	Stainless Steel White on White Black on Black
Frameless Drawer Front	•	•
Handle Style	Tubular	Tubular
<b>ACCESSORIES</b>		
1/4" Custom Wood Panel Kit	ZXD30B	ZXD27B
Pan Set	JXPN1	JXPN1
<b>GENERAL FEATURES</b>		
Interior Dimensions ( <i>WxHxD in inches</i> )	23-7/8 x 6-1/4 x 22-1/16	20-7/8 x 6-1/4 x 22-1/16
Overall Dimensions ( <i>WxHxD in inches</i> )	30 x 10-1/2 x 23-1/4	26-3/4 x 10-1/2 x 23-1/4
KW Rating @ 120VAC	.45	.45
Circuit 15 Amps @ 120VAC	•	•
Element Wattage	450	450
Approx. Shipping Weight ( <i>lbs.</i> )	65	59
Full One-Year Warranty*	•	•

\*See written warranty for details.

**Important Installation Note:** Must provide anti-tip brace at the back of the cabinet and at the top of the cutout.



# Microwave Ovens

## ZMC1095SB, ZMC1095WB and ZMC1095BB Built-In Microwave Ovens

Note: Reference pub. no. 49-8978 for ZMC1095SB, ZMC1095WB and ZMC1095BB, GE Monogram Built-In Microwave Oven Installation Instructions, for complete details.

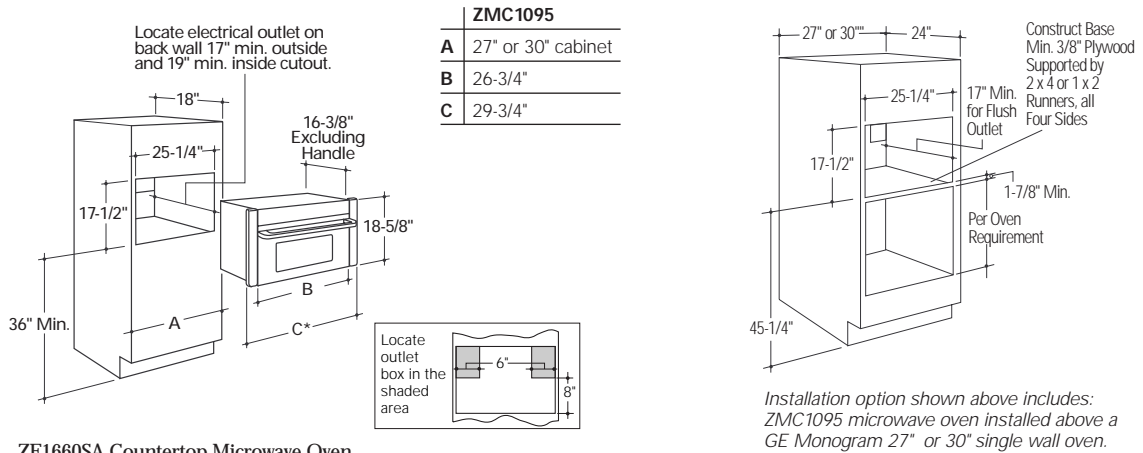

## ZE1660SA Countertop Microwave Oven

Note: Reference pub. no. 31-1169-2 for 27" Trim Kit, 31-1168-2 for 30" Trim Kit, GE Monogram Built-In Microwave Oven Installation Instructions, for complete details.

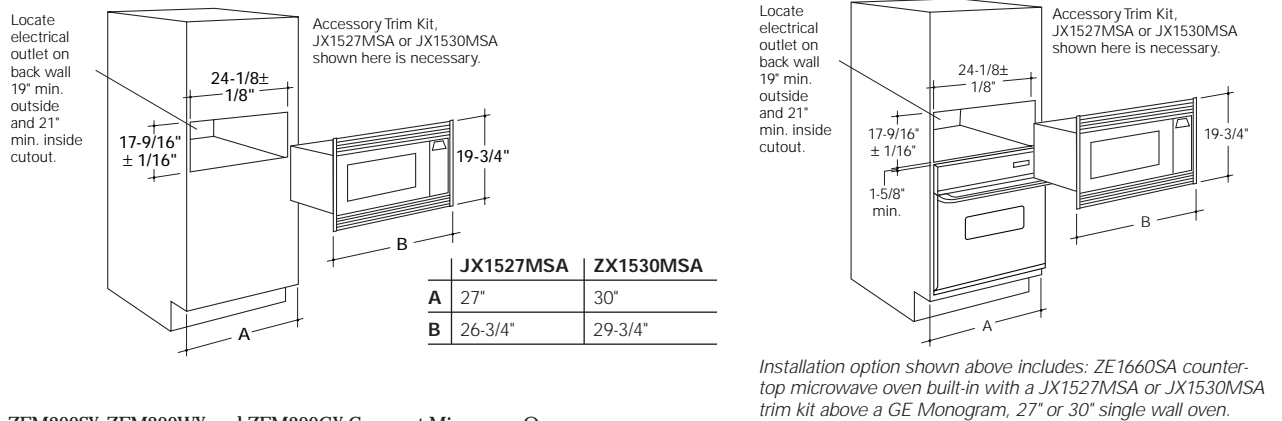

## ZEM200SY, ZEM200WY and ZEM200GY Compact Microwave Oven

Note: Reference pub. no. 49-8893, GE Monogram Compact Microwave Oven Installation Instructions, for complete details.

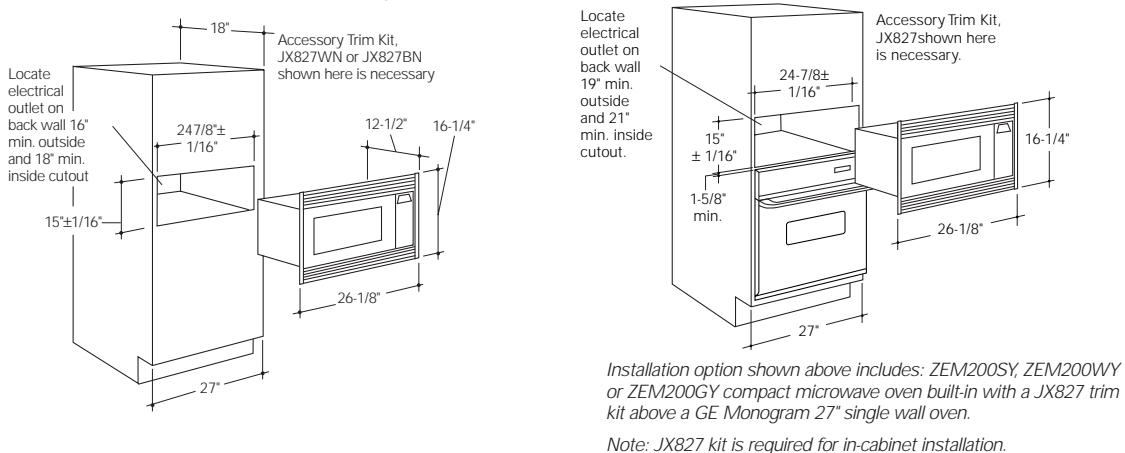



## Microwave Ovens

	ZMC1095SB ZMC1095WB ZMC1095BB	ZE1660SA	ZEM200SY ZEM200WY ZEM200GY
<b>DESCRIPTION</b>	Built-In Microwave Oven	Countertop Microwave Oven	Compact Microwave Oven
<b>PERFORMANCE</b>			
Oven Cavity ( <i>cu. ft.</i> )	1.0	1.6	.9
Watts (IEC-705 Test Procedure)	800	1,000	800
Electronic Touch Controls	•	Scrolling Display	•
Instant-On Controls	•	•	•
Ten Power Levels	•	•	•
Micro Cook I & II	•	•	•
Sensor Cooking Controls	Popcorn, Beverage, Reheat, Cook (Vegetable 1,2,3/ Potato/Fish/Chicken/Meat)	Potato, Vegetable and Popcorn	Cook, Reheat, Popcorn and Beverage
Convection Cook	•		
Combination Cook	•		
Combination Roast ( <i>probe</i> )	•		
<b>CONVENIENCE</b>			
Temp Cook/Hold ( <i>probe</i> )	•		
Minute Pad	•		
Add 30 Seconds	•	•	•
Express Cook	•	•	•
Kitchen Timer	•	•	•
Delay/Start Reminder	•	•	•
Auto Defrost	•	•	•
Time Defrost	•	•	•
Child Lock Out		•	•
Beeper Volume	Variable	4 Levels	
Sound On/Off		•	
<b>APPEARANCE</b>			
Stainless Steel Interior	•		
Color Appearance	White Black	Stainless door w/greystone case	Stainless door w/greystone case White door w/white case Black door w/greystone case
<b>GENERAL FEATURES</b>			
Optional Built-In Kit	None Required	JX1527MSA JX1530MSA	JX827SS JX827WN JX827BN
2450 Frequency ( <i>MHz</i> )	•	•	•
Watts	1450	1300	1300
Amps @ 120VAC	13.0	13.0	12.5
Interior Dimensions ( <i>WxHxD in inches</i> )	18 x 8-3/16 x 11-1/2	16-1/2 x 9-23/32 x 16-27/32	16-1/2 x 7-7/16 x 11-1/4
Overall Dimensions ( <i>WxHxD in inches</i> )	26-3/4 x 18-5/8 x 16-3/8*	23-21/32 x 13-5/16 x 18-5/16	23-25/32 x 11-3/16 x 12-9/32**
Approx. Shipping Weight ( <i>lbs.</i> )	84	50	46
Full One-Year Warranty†	•	•	•
Additional 9-Year Magnetron Warranty†	Limited	Limited	Limited

\*Exterior dimensions: depth excludes handle.

\*\*Exterior dimensions: height includes feet.

†See written warranty for details.

# Refrigerators

ZISW48DY, ZISB48DY, ZISS48DASS, ZIS48NY, ZISS48NASS, ZISW42DY, ZISB42DY, ZISS42DASS, ZIS42NY, ZISS42NASS, ZISW36DY, ZISB36DY, and ZIS36NY Built-In Refrigerators

Note: For installation instructions and custom options guides, reference pub. no. 49-6962-1 for 48" ZIS48 models, pub. no. 49-6963-1 for 42" ZIS42 models, pub. no. 49-6964-1 for 36" models and pub. no. 49-6951-3 for ZISS48 and ZISS42 models.

	ZISW48DY ZISB48DY ZIS48NY	ZISS48DASS ZISS48NASS	ZISW42DY ZISB42DY ZIS42NY	ZISS42DASS ZISS42NASS	ZISW36DY ZISB36DY ZIS36NY
<b>A*</b>	84"	84"	84"	84"	84"
<b>B†</b>	48"	48"	42"	42"	36"
<b>C</b>	24-3/4"	24-3/4"	24-3/4"	24-3/4"	24-3/4"
<b>D</b>	83-1/4" to 84-1/2"	83-1/4" to 84-1/2"	83-1/4" to 84-1/2"	83-1/4" to 84-1/2"	83-1/4" to 84-1/2"
<b>E†</b>	47-1/2" to 48"	47-1/2" to 48"	41-1/2" to 42"	41-1/2" to 42"	35-1/2" to 36"
<b>F</b>	24" to 24-3/4"	24" to 24-3/4"	24" to 24-3/4"	24" to 24-3/4"	24" to 24-3/4"

\*Grille panel can be adjusted from 83" to 84-1/2" using the adjustable grille panel kits.  
 †The minimum cutout widths shown will result in a semi-flush installation. For a flush installation, the opening must be equal to the full product width dimension B. Additional cutout width may be required when side panels are used. Add side panel thickness to the finished cutout width to calculate rough-in width. See installation instructions for details.

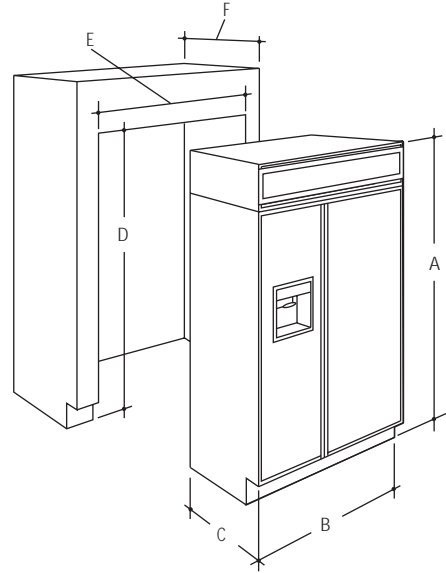

Electrical Outlet Location  
 36" Models 12-3/8"  
 42" Models 18-3/8"  
 48" Models 20-3/8"

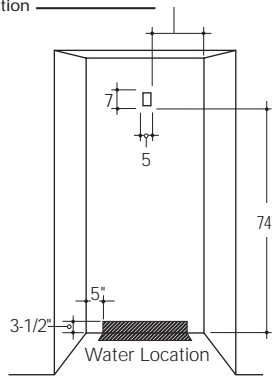

Water location information:  
 Any location 3-1/2" on back wall or the floor, or at least 5" from either side.

## ZFSB27DASS Free-Standing Refrigerator

Note: Reference pub. no. 49-6894-2, GE Monogram Free-Standing Refrigerator Installation Instructions, for complete details.

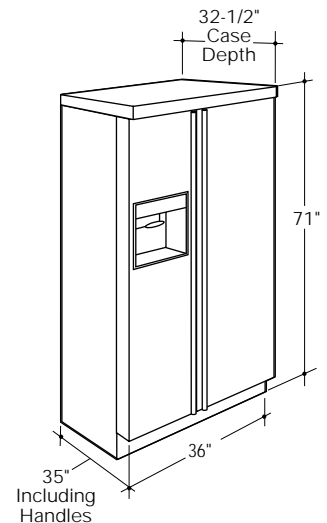



## Refrigerators

	ZISW48DY* ZISB48DY* ZISS48DASS†	ZIS48NY* ZISS48NASS†	ZISW42DY* ZISB42DY* ZISS42DASS†	ZIS42NY* ZISS42NASS†	ZISW36DY* ZISB36DY*	ZIS36NY*	ZFSB27DASS
<b>DESCRIPTION</b>	48" Built-In Refrigerator with Dispenser	48" Built-In Refrigerator	42" Built-In Refrigerator with Dispenser	42" Built-In Refrigerator	36" Built-In Refrigerator with Dispenser	36" Built-In Refrigerator	Stainless Steel Free-Standing Refrigerator
<b>CAPACITY</b>							
Total (cu. ft.)	29.8	30.2	25.7	25.8	21.2	21.4	26.6
Fresh Food (cu. ft.)	17.8	17.8	16.4	16.4	12.0	12.0	16.9
Freezer (cu. ft.)	12.0	12.4	9.3	9.4	9.2	9.4	9.72
Shelf Area (sq. ft.)	35.1	37.1	31	31.7	25.7	25.9	28.4
<b>FRESH FOOD SECTION</b>							
Adj. Spill-Proof Glass Shelves	4	4	4	4	4	4	3 (2 Slide-Out)
Slide-Back Shelf	•	•	•	•	•	•	•
Adj. Humidity, Slide-Out Vegetable/ Fruit Pan w/Full-Extension Slides	2	2	2	2	2	2	1 Slide-Out
Sealed Snack Pan w/Full-Extension Slides	•	•	•	•	•	•	Adj. Humidity/ Slide-Out
Adj. Temp. Slide-Out Meat Pan							•
Adj. Door Bins	5	5	5	5	5	5	4
Gallon Door Storage	•	•	•	•	•	•	•
Sealed Dairy Compartment	2	2	2	2	1	1	1
Utility Bin							•
Glass-Covered Butter Dish	•	•	•	•	•	•	•
Door Bin Divider	•	•	•	•	•	•	•
Wine Caddy	•	•	•	•	•	•	•
<b>FREEZER SECTION</b>							
Utility Baskets w/Full-Extension Shelves	2	2	2	2	2	2	1
Adjustable Shelves (Wire)	4	4	4	4	4	4	3
Adj. Door Bins	3	5	3	5	3	5	5
Automatic Icemaker	•	•	•	•	•	•	•
Removable Ice Storage Bin	•	•	•	•	•	•	•
Exterior Dispenser (Cubes, Crushed Ice & Chilled Water)	•		•		•		•
<b>GENERAL FEATURES</b>							
Sealed System Design w/Independent Temperature Controls	•	•	•	•	•	•	•
Four Adjustable Rollers	•	•	•	•	•	•	•
Leveling System	•	•	•	•	•	•	•
Door Stops	•	•	•	•	•	•	•
Coil-Free Back	•	•	•	•	•	•	•
Available Dispenser Color(s)	White Black Black	N/A	White Black Black	N/A	White Black	N/A	Black
Overall Dimensions (WxHxD in inches)	48 x 83-84-1/2 x 24-3/4††	48 x 83-84-1/2 x 24-3/4††	42 x 83-84-1/2 x 24-3/4††	42 x 83-84-1/2 x 24-3/4††	36 x 83-84-1/2 x 24-3/4††	36 x 83-84-1/2 x 24-3/4††	36 x 71 x 32-1/2
115 Volts/20 Amps	•	•	•	•	•	•	•
Approx. Shipping Weight (lbs.)	580	580	540	540	475	475	498
Full Warranty**	Two-Year	Two-Year	Two-Year	Two-Year	Two-Year	Two-Year	One-Year
Full Five-Year Warranty** On Sealed Refrigeration System	•	•	•	•	•	•	•
12-Year Warranty** On Sealed System Parts	Limited	Limited	Limited	Limited	Limited	Limited	

\*Trim kit required.

†Full stainless wrap, no trim kit required.

\*\*See written warranty for details.

††Depth can include a 3/4" custom panel.

## Bottom-Mount Refrigerators

ZIC36NARH, ZIC36NALH and ZICS36NARH, ZICS36NALH Bottom-Mount Refrigerators

Note: The finished cut-out is determined by the type of installation. Order pub. no. 49-6984-3 for model ZICS36NARH/LH for complete instructions and pub. no. 49-60000-3 for model ZIC36NARH/LH for complete instructions and custom options guide.

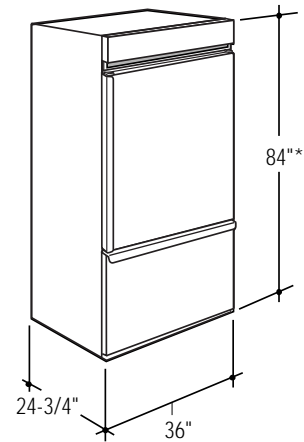
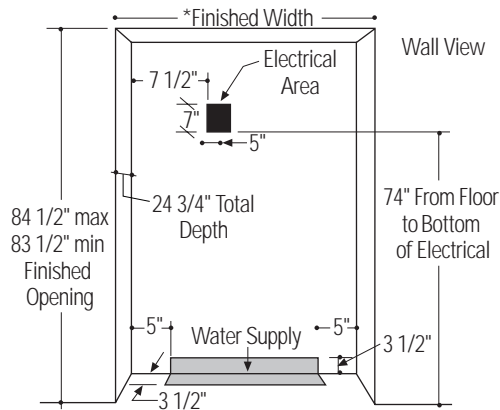

\* 36" min. for a flush installation 35-1/2" min. for a semi-flush installation.

Note: Additional cut-out width may be required when side panels are used. Add side panel thickness to the finished cut-out to calculate rough-in width. See installation instructions for details.

\* Shipped at 84" installation height. Grille panels can be adjusted to 83-1/2" or 84-1/2" installation height with grille panel kits.

Note: ZIC36NALH and ZICS36NALH models have hinges on the left side and the door swings from right to left. ZIC36NARH and ZICS36NARH models have hinges on the right side and door swings from left to right.

## Bottom-Mount Refrigerators

	ZIC36NARH ZIC36NALH	ZICS36NARH ZICS36NALH
<b>DESCRIPTION</b>		
	36" Built-In Refrigerator	36" Built-In Stainless Steel Refrigerator
<b>CAPACITY</b>		
Total (cu. ft.)	20.8	20.8
Fresh Food (cu. ft.)	14.1	14.1
Freezer (cu. ft.)	6.7	6.7
<b>FRESH FOOD SECTION</b>		
Adj. Spill-Proof Glass Shelves	4 Adj./1 Fixed	4 Adj./1 Fixed
Adj. Humidity, Slide-Out Vegetable/ Fruit Pan w/Easy Access Lid on Full-Extension Slides	2	2
Sealed Snack Pan w/Full-Extension Slides	2	2
Door Bins	4 Adj./2 Fixed	4 Adj./2 Fixed
Gallon Door Storage	•	•
Sealed Dairy Compartment	2	2
Egg Bin	•	•
Glass-Covered Butter Dish	•	•
Wine Caddy	•	•
<b>FREEZER SECTION</b>		
Wire Shelves on Full-Extension Slides	2-Tier	2-Tier
Automatic Icemaker	•	•
Removable Ice Storage Bin	•	•
<b>ACCESSORIES</b>		
Stainless Steel Tubular Handle Kit	•	
1/4" Custom Panel Kit	White, Black, Stainless Steel	
3/4" Custom Panel Kit	•	
<b>GENERAL FEATURES</b>		
Sealed System Design w/Independent Temperature Controls	•	•
Four Adjustable Rollers	•	•
Leveling System	•	•
130° Door Stops	•	•
Coil-Free Back	•	•
Standard Extruded Handles	•	Stainless Steel Tubular Handles
Overall Dimensions (WxHxD in inches)	36 x 83-1/2-84-1/2 x 24-3/4†	36 x 83-1/2-84-1/2 x 24-3/4
Adjustable Soffit Kit 83-1/2" to 84-1/2"	•	•
115 Volts/20 Amps	•	•
Approx. Shipping Weight (lbs.)	475	475
Full Warranty*	Two-Year	Two-Year
Full Five-Year Warranty* On Sealed Refrigeration System	•	•
12-Year Warranty* On Sealed System Parts	Limited	Limited

†Depth includes 3/4" custom panel.  
\*See written warranty for details.



## Wine Chiller & Beverage Center

ZDW24AWW, ZDW24ABB Wine Chiller and  
ZDB24AWW, ZDB24ABB Beverage Centers

Note: Reference pub. no. 49-6980-1 for Wine Chiller, and 49-6981-1 for Beverage Center Installation Instructions, for complete details.

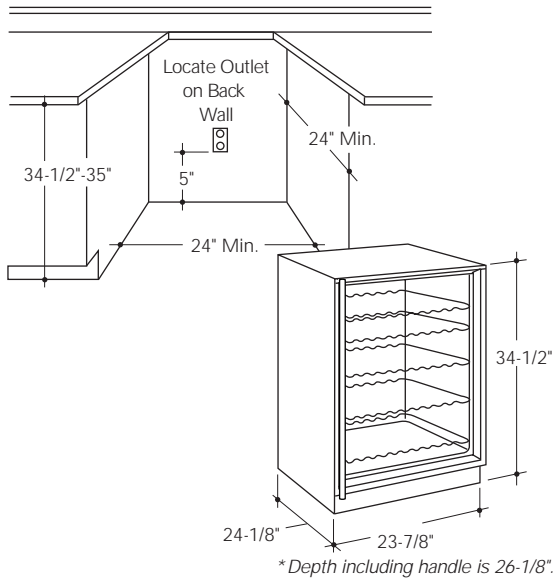

## Icemakers

ZDI15CWW, ZDI15CBB and ZDIS15CSS Icemakers

Note: The finished cut-out is determined by the type of installation. Order pub. no. 49-60016 for complete instructions.

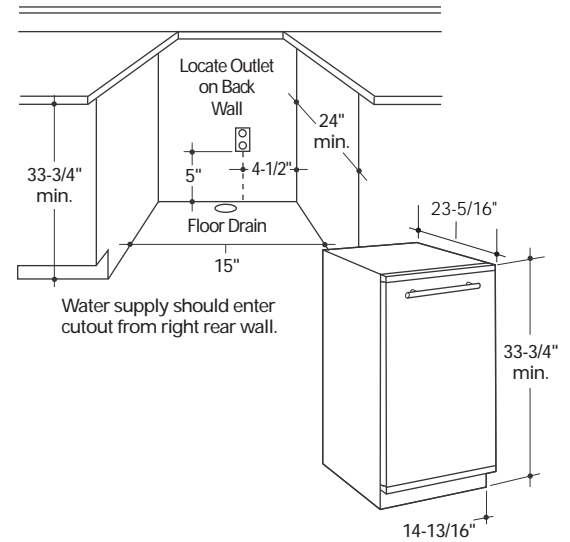

## Compactors

ZCG3300VWW, ZCG3100VBB, and ZCG3500DSS Compactors

Note: Reference pub. no. 49-5778-2, GE Monogram Compactor Installation Instructions, for complete details.

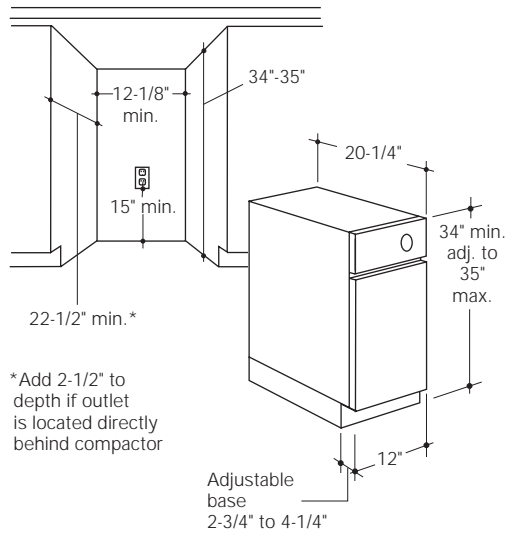

## Wine Chiller and Beverage Center

	ZDW24AWW ZDW24ABB	ZDB24AWW ZDB24ABB
<b>PERFORMANCE</b>		
Total Capacity	50 Wine Bottles	14 Wine Bottles plus Beverages
Slide-Out Shelves	5	2
Fixed Shelves	2	3
<b>CONVENIENCE</b>		
Adj. Temperature Control Beverage Center Section		Mid 30° to Mid 40°
Adj. Temperature Control Wine Section	Low 40° to Mid 60°	Mid 40° to Mid 50°
Interior Light	Auto/Manual	Auto/Manual
<b>APPEARANCE</b>		
Colors Available	White Black	White Black
Stainless Steel Door and Tubular Handle	•	•
<b>GENERAL FEATURES</b>		
Installation Options	Built-In or Free-Standing	Built-In or Free-Standing
See-Thru Glass Door	•	•
Reversible Door Swing	•	•
Overall Dimensions ( <i>WxHxD in inches</i> )	23-7/8 x 34-1/2 x 24-1/8	23-7/8 x 34-1/2 x 24-1/8
Amps @ 115 Volts	2.0	2.0
Approx. Shipping Weight ( <i>lbs.</i> )	126	130
Full One-Year Warranty*	•	•
Full Five-Year Warranty* On Sealed Refrigeration System	•	•

\*See written warranty for details.

## Compactors

	ZCG3300VWW ZCG3100VBB ZCG3500DSS
<b>PERFORMANCE</b>	
1/3 HP Motor	•
5,000 lb. Maximum Compacting Force	•
Automatic Anti-Jamming Feature	•
<b>CONVENIENCE</b>	
Slide-Out Compactor Drawer	•
Lock/Start Control With Removable Key	•
<b>APPEARANCE</b>	
Colors Available	White Black Stainless Steel
White/Black Reversible Drawer Panel	Black and White Models
Adjustable Base (Toekick Depth)	•
Accepts Stainless Steel Panels	Order 24-M117 (Black & White Models)
Drawer Trim Accepts 1/4" Custom Panel	Black & White Models
Adaptable To Accept 3/4" Panel	Black & White Models
<b>GENERAL FEATURES</b>	
Overall Dimensions ( <i>WxHxD in inches</i> )	12 x 34-35 x 20-1/4
120 Volt	•
Amps @ 120 VAC	5
Approx. Shipping Weight ( <i>lbs.</i> )	135
Full One-Year Warranty*	•

\*See written warranty for details.

## Icemakers

	ZD115CWW ZD115CBB ZDIS15CSS
<b>PERFORMANCE</b>	
Daily Ice Production	50 lbs.
Storage Bin	25 lbs.
<b>CONVENIENCE</b>	
Automatic Shut-Off	•
Cast Aluminum Ice Scoop	•
Interior Light	•
Electronic Control with Pushpads	•
Cycles	On/Off/Clean
Clean Light	•
<b>APPEARANCE</b>	
Colors	White Black Stainless Steel
Full-Length Door	•
Handle	White, Black, Stainless Steel Tubular
Accepts 3/4" Custom Panels	ZIP75WW ZIP75BB
Reversible Door	•
100° Door Stop	•
<b>GENERAL FEATURES</b>	
Overall Dimensions ( <i>WxHxD in inches</i> )	14-13/16 x 33-3/4 x 23-5/16
Amps @ 120 Volts	5.3
Drain Pump Accessory Kit	ZPK1
Full One-Year Warranty*	•
Full Five-Year Warranty* On The Compressor, Evaporator And All Connection Tubing	•

\*See written warranty for details.

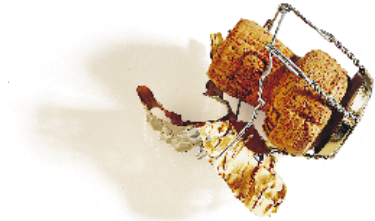

## Dishwashers

ZBD5900DSS, ZBD5700DWW, ZBD5700DBB, ZBD5600DWW and ZBD5600DBB Dishwashers

Note: Reference pub. no. 49-5860, GE Monogram ZBD5900DSS, ZBD5700DWW, ZBD5700DBB, ZBD5600DWW and ZBD5600DBB Dishwasher Installation Instructions, for complete details.

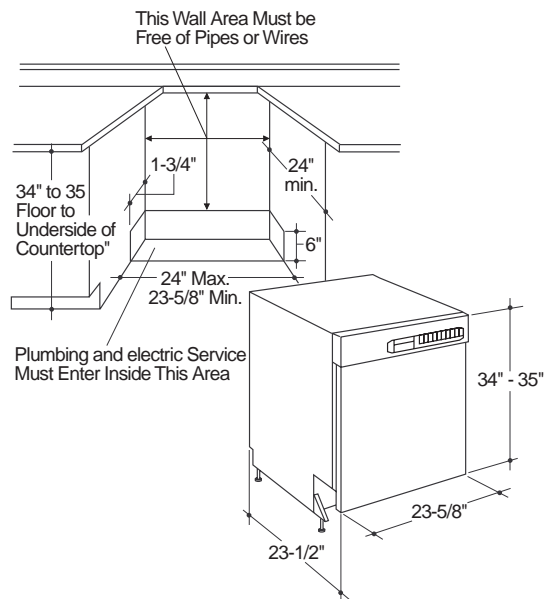

ZBD4200DWW, ZBD4200DBB and ZBD4500DSS Dishwashers

Note: Reference pub. no. 49-5850, GE Monogram ZBD4200D and ZBD4500D Dishwasher Installation Instructions, for complete details.

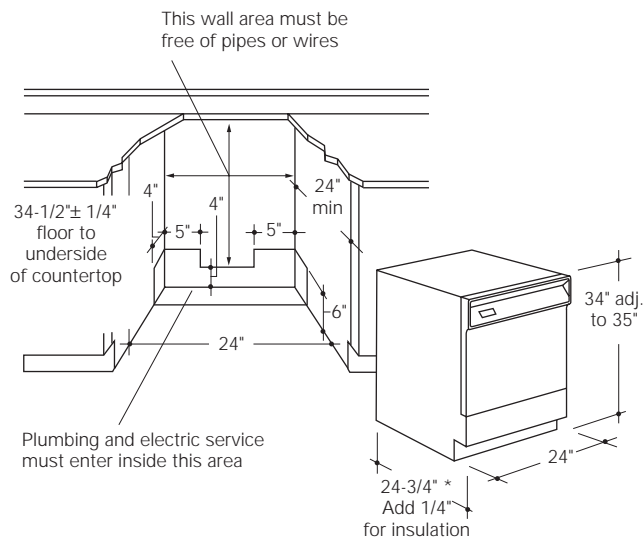



## Dishwashers

	ZBD5900DSS	ZBD5700DWW ZBD5700DBB	ZBD5600DWW ZBD5600DBB	ZBD4200DWW ZBD4200DBB	ZBD4500DSS
<b>FEATURES</b>					
Control Type	Electronic	Electronic	Turn-To-Start	Electronic	Electronic
QuickClean Controls				•	•
Cycle Status Indicators	5	5	Dial	6	6
Touchpads/Knobs	8 Pads	8 Pads	2 Knobs	11 Pads	11 Pads
Cycle/Options	19 Combinations	19 Combinations	17 Combinations	Variable	Variable
<b>CYCLES</b>					
<i>(Super Wash)</i> Pots & Pans	•	•	•	•	•
Normal	•	•	•	•	•
<i>(Light Wash)</i> China/Crystal			•	•	•
<i>(Fast Wash)</i> Speed Wash	•	•	•	•	•
Rinse & Hold	•	•	•	•	•
Sani Wash				•	•
CleanSensor Technology				•	•
<b>OPTIONS</b>					
Water Temp	Norm/Boost/Sani	Norm/Boost/Sani	Norm/Boost		
<i>(Heated Dry)</i> Speed Dry	•	•	•	•	•
Delay Start	2/4/6 Hour	2/4/6 Hour		2/4/8 Hour	2/4/8 Hour
Clear/Reset or Cancel	•	•	•	•	•
Electronic Child Lock Out	•	•		•	•
Cycle Auto Memory	•	•		•	•
Power Pre-Soak				•	•
<b>APPEARANCE</b>					
Door Panel Color	Stainless Steel	White Black	White Black	White Black	Stainless Steel
Accepts Stainless Steel Panels	Standard			Order GPF400S*	Standard
Accepts 3/4" Custom Panels		Order ZPF75W/ ZPF75B	Order ZPF75W/ ZPF75B	Order GPF475*	
Accepts 1/4" Custom Panels		Order ZPF25W/ ZPF25B	Order ZPF25W/ ZPF25B	Order GPF425W/ GPF425B	
<b>GENERAL FEATURES</b>					
Stainless Steel Interior	•	•	•		
PermaTuf® Interior				•	•
Interior Light	•	•			
Upper Rack	Nylon 2-Position	Nylon 2-Position	Nylon 2-Position	Nylon w/ Fold-Down Tines	Nylon w/ Fold-Down Tines
Lower Rack	Nylon w/ Fold-Down Tines	Nylon w/ Fold-Down Tines	Nylon w/ Fold-Down Tines	Nylon w/ Fold-Down Tines	Nylon w/ Fold-Down Tines
Silverware Basket	Deluxe w/Cell Covers	Deluxe w/Cell Covers	Deluxe w/Cell Covers	Split w/Cell Covers	Split w/Cell Covers
Utility Shelves	4	4	4	4	4
Wash Levels	5	5	5	5	5
Upper-Level Wash Arm				•	•
Mid-Level Wash Arm	Stainless Steel	Stainless Steel	Stainless Steel	•	•
Lower Wash Arm	Stainless Steel	Stainless Steel	Stainless Steel	•	•
Filter System	Stainless Steel 4-Way	Stainless Steel 4-Way	Stainless Steel 4-Way	Triple	Triple
Rinse Aid Dispenser	•	•	•	•	•
Sound Insulation Package	Monogram	Monogram	Monogram	•	•
Overall Dimensions ( <i>WxHxD in inches</i> )	23-5/8 x 34-35 x 23-1/2	23-5/8 x 34-35 x 23-1/2	23-5/8 x 34-35 x 23-1/2	24 x 34-35 x 25	24 x 34-35 x 25
Amp. Rating ( <i>120V/60 Hertz</i> )	12.0	12.0	12.0	8.6	8.6
Approx. Shipping Weight ( <i>lbs.</i> )	110	110	110	81	81
Full One-Year Warranty**	•	•	•	•	•
Second Year Warranty** Parts	Limited	Limited	Limited	Limited	Limited
Five-Year Warranty** On Upper and Lower Racks	Limited	Limited	Limited	Limited	Limited
Five-Year Warranty** On Electronic Control Module	Limited	Limited		Limited	Limited
Full Lifetime Warranty** On Stainless Steel And PermaTuf® Interiors	•	•	•	•	•

\*GPF100 heavy spring kit (to be used if custom door panel weighs more than 4 lbs.) is included with kits GPF400S and GPF475.  
\*\*See written warranty for details.



ZGG36L31ASS 36" Outdoor Cooking Center, ZX36CTYSS 36" Cart

You no longer have to compromise your gourmet standards just because you don't have a roof over your head.

The Monogram™ Outdoor Collection offers stainless steel gas cooking centers designed for built-in or free-standing applications. Grill configurations range from the simple to the sophisticated—from a 24" two-burner grill to a complete 48" cooking center. The latter joins three grill sections with a rotisserie, a smoker, and an integrated dual-burner outdoor cooktop. Grill burners are equipped with multi-spark igniters for easy lighting. Sturdy knobs glide from low to high settings, allowing precise control of the 20,000-BTU burners. Controls are mounted on brass valves to provide precise flame control and ensure long life in the outdoors. The infrared rotisserie burners are mounted behind the motorized rotisserie (*this makes them immune to "flare-ups"*). A smoker burner is standard on all 36" and 48" grills, and an integrated dual-burner cooktop surface is offered in cooking centers of either size. The 15,000-BTU cooktop burners allow you to prepare side dishes while grilling. A stainless steel cover protects the cooktop burners when not in use. A separate dual-burner cooktop can be installed alongside built-in cooking centers or mounted on the 27" cart to expand the cooking area. A variety of accessories includes, stainless steel access doors for island installations and portable, stainless steel carts.



*The GE Monogram Outdoor Collection presents beautifully-styled stainless steel gas cooking centers designed for free-standing or built-in applications.*



*For a copy of The Monogram Outdoor Collection Catalog call The GE Answer Center® 800.626.2000*

Exceptional service is a standard feature.

Monogram™ offers a feature no other brand can match: customized services that begin before you've selected your appliances and continue until well after your kitchen has become a reality. The Monogram Collection™, a superb line of kitchen appliances with a package of services to match.

**GE Answer Center® 800.626.2000.** For technical assistance and answers to your questions about Monogram appliances any time.

**Monogram Preferred Service, 800.444.1845.** Connects you with a specialist who can schedule a service call within 24 hours.

**Visit <http://www.monogram.com>.** To view Monogram specifications, installation information and owner's manuals online.

**GE QuickSpecs, 800.432.3729.** To request dimensions and specifications on any Monogram appliance, and have the data transmitted, within minutes, to the fax number you provide.



**Monogram®**  
*We bring good things to life.*

*General Electric Company  
Louisville, Kentucky 40225*

*All Monogram products are appropriately  
UL or AGA approved.*

*Product improvement is a continuing  
endeavor at General Electric. Therefore,  
materials, appearance and specifications  
are subject to change without notice.*

*\$30.00*

*Publication Number 24-M218-1*